

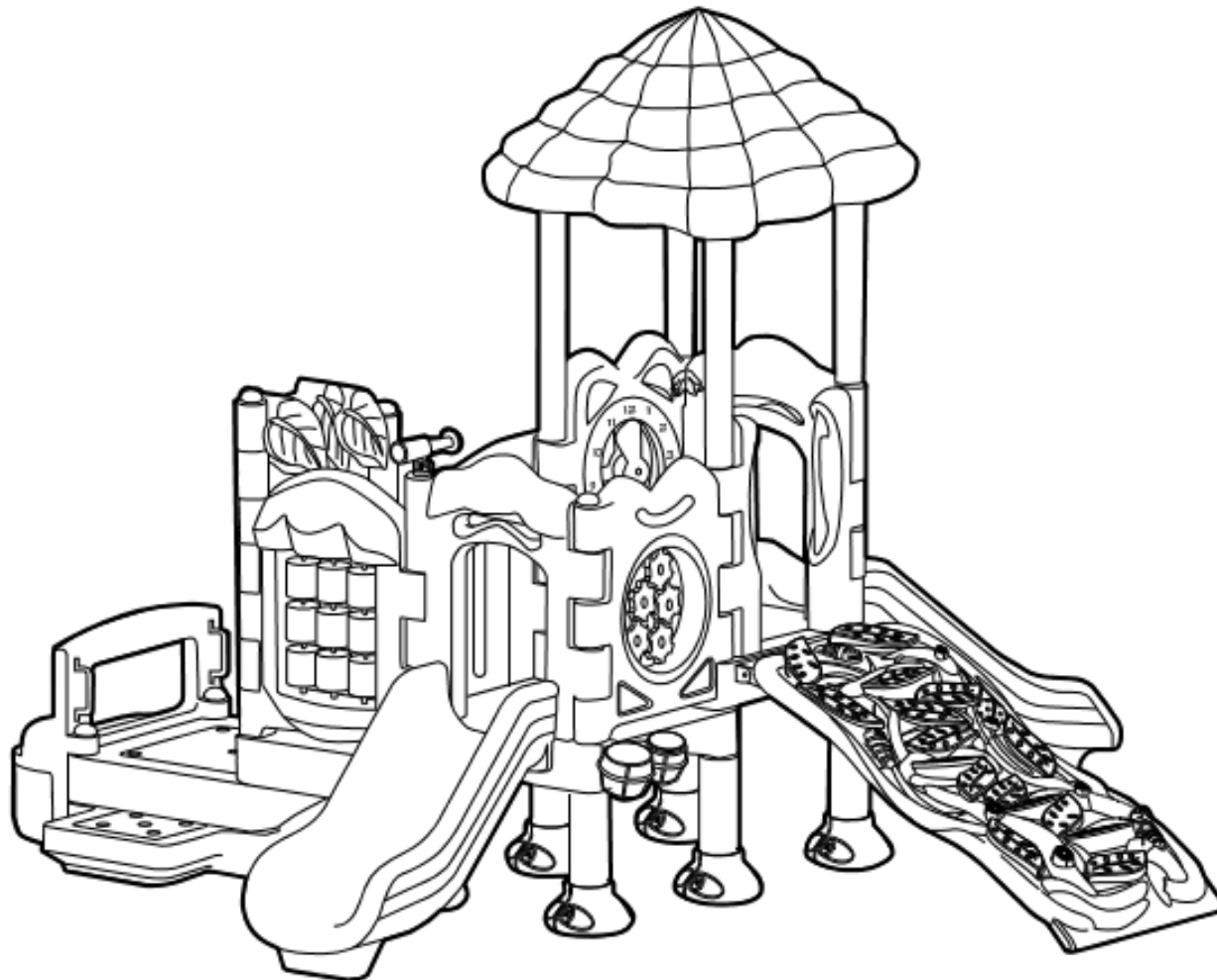

## Discovery Center 4

SKU: 622pg215



# GENERAL COMMERCIAL PLAYGROUND SAFETY GUIDELINES (page 1 of 5)

Maintaining your playground equipment and its surrounding area is essential to minimizing the risk of injury to users as well as maximizing its useful lifespan. Manufacture **STRONGLY** recommends that you follow these Safety Guidelines in conjunction with conducting periodic maintenance inspections using the accompanying *Playground Maintenance Checklist*.

When installing your playground, always consider local conditions. Good common sense works hand-in-hand with the instructions.

## LOCATING YOUR PLAY STRUCTURE:

**Comply with the following when choosing the location for your new equipment:** Equipment shall be positioned to eliminate conflicting traffic patterns. As a general rule, allow at least 6' of free space around the entire structure, EXCEPT for slide exits, which require a distance  $X$  equal to the highest point of the sliding surface with a minimum of 72 inches and maximum of 96 inches from the edge of the slide. See *Figure 1* below (example: a Slide from a 6 foot deck requires 6 feet of clear space with resilient surfacing in front of its exit). Discovery Centers slides are 4 feet or shorter; therefore, the slide exit use zone is 72 inches. Swings must have a minimum of twice the swing beam height of free space in front and behind them for safe circulation. See *figure 2* below (example: a swing with an 8 foot high top rail requires 16 feet of free space in front and another 16 feet behind it, for a total of 32 feet). These minimum areas should be filled with the appropriate resilient surface material. Read further for resilient surfacing recommendations.

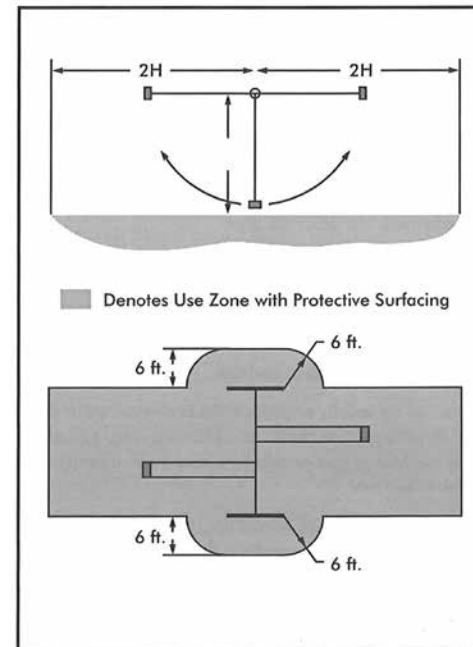
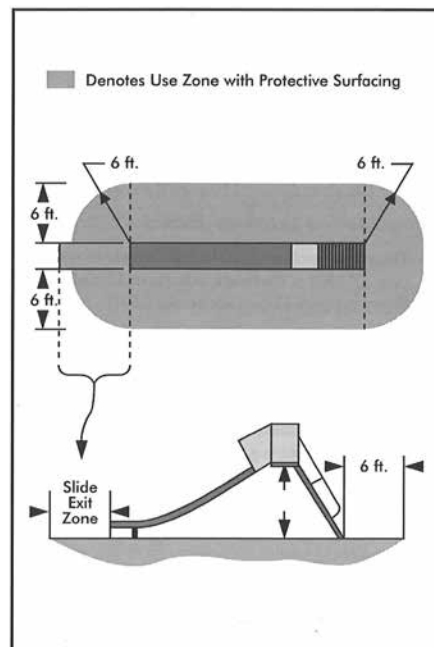

## GENERAL COMMERCIAL PLAYGROUND SAFETY GUIDELINES (Page 2 of 5)

Never overlap the safety zones of adjacent equipment. All separate play equipment must have its own safety zone, and these cannot overlap. If you have an existing structure with a slide exit oriented toward your new one, add a minimum safety zone to that of the existing slide to determine how far away you need to be.

Never install playground equipment near, around, or in conjunction with swimming pools, ponds, lakes or any other bodies of water.

### **CHOOSING RESILIENT SURFACE MATERIAL:**

Playground equipment must be installed on a soft, resilient, energy-absorbing ground surface. **NEVER INSTALL EQUIPMENT ON CONCRETE, ASPHALT OR EVEN GRASS!** A fall on a hard surface from even as low as a 3 foot high deck has been found to result in serious injury to the user. For most play equipment, these surfaces should contain a minimum of 12 inches of wood fiber or other loose fill material intended for playground surfacing use. For more information on the proper surfacing materials, call the CPSC hotline at 1-800-638-2772.

Soft, resilient surfacing should be placed in the use zones of all equipment, as specified for each type of equipment, and at depths to meet the critical fall heights as specified by the U.S. Product Safety Commission, ASTM standard F1487 and Canadian Standard CAN/CSA-Z-614. Equipment should be placed to eliminate conflicting traffic patterns.

**Tip:** If your surfacing is of the loose variety, checking for proper depth over time can be made easy by applying a non-removable fluorescent tape or paint in a bright color at the proper level on each upright post. Thereafter, as the resilient material compacts or washes away, the person responsible for regular maintenance inspections can easily see it must be replenished as the marks become visible.

### **OVERHEAD OBSTRUCTIONS:**

Overhead obstructions within the use zones of playground equipment that are not part of the play structure (for example, tree limbs) shall be at least 84 inches (2130 mm) above each designated play surface or 84 inches (2130 mm) above the pivot point of swings.

All overhead utility line clearances above the use zone areas shall comply with all local, state, and national codes, such as the National Electrical Safety Code. For specific overhead obstruction requirements, refer to the CPSC and ASTM F1487 and use the more stringent of the two.

## GENERAL COMMERCIAL PLAYGROUND SAFETY GUIDELINES (Page 3 of 5)

### **CATCH POINT & PROTRUDING HARDWARE:**

There should be no dangerous pieces of hardware, such as protruding bolt ends and narrow gaps in metal connections or open “S” hooks at the top and bottom of swings. Exposed hardware can cut children, puncture skin, or catch clothing drawstrings, which could strangle a child.

All protruding nuts and bolts should be eliminated; sharp edges on pipes should be capped or removed. Check for bent, broken, or severely worn pipe and replace. Examine slide bedways, bedrails, handrails and exits for foreign objects, holes, and rough edges.

### **TRIPPING HAZARDS:**

There should be no exposed concrete footings, abrupt changes in surface elevations, tree roots, tree stumps, and rocks, which can trip children and adults. Check for trip hazards, such as the balance beam support posts, or environmental trip hazards, such as rocks or roots in the play area. Make all necessary improvements or repairs.

### **AFTER THE EQUIPMENT IS IN USE:**

- Never add components not intended for use with this product.
- Never install other play equipment, fencing, landscaping, etc., which encroach upon the safety zones of this equipment.
- Check overall stability and rigidity of all play equipment.
- Check for proper assembly, installation and ground anchoring.
- Check and re-tighten all fasteners after the first few days of use and again after three weeks of use. Thereafter, exercise normal maintenance procedures. Use of a thread-locking compound on the threads of bolts can prevent persistent loosening.
- Swing “S” hooks must be completely closed. Replace worn “S” hooks and never re-use them.

# GENERAL COMMERCIAL PLAYGROUND SAFETY GUIDELINES (Page 4 of 5)

## **ROUTINE MAINTENANCE:**

Regularly inspect and maintain your playground equipment and its surrounding area to ensure the safety of the user. Proper maintenance of Discovery Centers equipment includes using the accompanying **Playground Maintenance Checklist** found in the back of this booklet to identify areas requiring repairs or replacement, and barricading the equipment to prevent use while corrections are being made.

As the Owner/Operator of the equipment, you should establish and maintain detailed installation, inspection, maintenance, and repair records for each public-use playground equipment area. Find out if your playground has a designated official who periodically inspects the play equipment for preventative maintenance. This includes: replacing missing, broken or worn-out components; securing hardware; checking for deterioration in the metal or plastic materials; maintaining the proper 12 inch depth of surfacing material; and cleaning up debris.

### **Following are some regular maintenance areas of note:**

- Check for and repair damage caused by wear or vandalism, a major factor in injury causing situations.
- Proper maintenance of Discovery Centers equipment requires regular tightening of all bolts, nuts, set screws and other hardware.
- All equipment should be free of rust and repainted with an appropriate lead-free paint whenever necessary to deter rusting. This should also be done for any chipped or peeling areas.
- Regular checking of all parts, casting, etc., should be made. If part is broken or worn it should be replaced immediately.
- Check for loose spring castings and tighten.
- Check for missing or broken parts, rungs, or steps and repair as necessary.
- Replace worn or damaged strap seats or other swing seats.
- Check for worn chains and replace them as needed.
- Check to be sure there is free movement of swing hanger and other moving attached parts.
- Check the vertical distance between the underside of the occupied swing seat and the protective surface. It should measure no less than 12 inches. Adjust swing seat height as necessary.
- Check for deformation of open “S” hooks, shackles, rings, links, etc. Check “S” hooks for excessive wear, making sure they are properly closed; never reuse an “S” hook.
- Check for worn swing hangers and chain. When these areas are identified, replacements should be made.

- Continued next page

## GENERAL COMMERCIAL PLAYGROUND SAFETY GUIDELINES (Page 5 of 5)

- Check for missing, damaged, or loose swing seats. Check rubber seats for wear, sharp edges/points, scorching, or burn damage. Repair and replace as needed.
- Check for swing chain wrapped around top rail and if found, unwrap. Replace chains as necessary.
- Check for hard surfaces and correct, including under swings, slides, etc., where loose surfacing may have been kicked away. Refer to CPSC surfacing requirements.
- Check for surfacing material that is worn or scattered and restore.
- Debris, broken glass, trash, or other foreign objects within or on the play area/equipment should be removed.
- Check for poor drainage areas and repair.
- Check concrete footings to see if they are exposed, cracked, or loose in the ground and repair as necessary.
- Check for lack of lubrication on all moving parts and lubricate as needed.
- Check crush points (exposed mechanisms, junctures of moving components) and eliminate.
- Check for broken support/anchors. Stability in ground, structures should not be easily swayed; connections should be solid and adequately secured.
- Check all posts in ground for corrosion or rot below grade.
- Check exit areas of slides. The exit area should be no more than 11 inches from the protective surface for slides under 4 feet high. For slides over 4 feet high, the height of the exit region from the surface should be between 7 and 15 inches.
- Check the surface area around slide exit for erosion and other damage and repair if necessary.
- Check for visible cracks, bending, warping, rusting, or breakage of any component and repair as needed.
- Check for accessible sharp edges or points. Check for protruding bars, bolts, nuts, etc. Eliminate these conditions.
- Check for exposed ends of tubing that should be covered with plugs or caps.
- Check for loose bolts, nuts, etc. and tighten.
- Check for broken or missing rails, steps, rungs, or seats and replace.
- Replace broken springs and seats on spring riders and other similar play events.

## WARRANTY DETAILS

Manufacture warrants its products to be free from defects in materials and/or workmanship, subject to normal usage and installation, for a period of 1-year from the date of shipment to the original purchaser. In the event of a claim under this warranty, manufacture will replace the component at no cost within the first 12 months from date of shipment to the original customer. Equipment not specifically addressed in the following paragraphs is also subject to this limited 1 year warranty against defects in materials and/or workmanship.

### TEN-YEAR LIMITED WARRANTY ON UPRIGHT POSTS, CAPS, AND HARDWARE

Manufacture provides a limited warranty on Discovery Centers metal upright posts, caps, and hardware to be free from defects in materials or workmanship against structural failure which causes the product to become unfit for its intended use, subject to normal usage and installation, for a period of 10 years from the date of shipment to the original customer.

### FIVE-YEAR LIMITED WARRANTY ON ROTOMOLDED AND BLOWMOLDED PLASTIC COMPONENTS

Manufacture provides a limited warranty on rotomolded and blowmolded plastic components such as the following plastic parts: slides, climbers, roofs, panels. These components are warranted to be free from defects in materials or workmanship, subject to normal usage and installation, for a period of 5 years from the date of shipment to the original customer.

### FIVE-YEAR LIMITED WARRANTY ON GROUND-MOUNT METAL PARTS

Manufacture provides a limited warranty on metal footers, inground footers, surface mount plates, ground spikes, slide and climber mounting posts and plates to be free from defects in materials or workmanship against structural failure which causes the product to become unfit for its intended use, subject to normal usage and installation, for a period of 5 years from the date of shipment to the original customer.

### ONE-YEAR LIMITED WARRANTY ON COMPONENTS WITH MOVING PARTS

Manufacture provides a limited warranty on components with moving parts, freestanding components such as spring riders and swings, and all other components not specifically named above to be free from defects in materials or workmanship against structural failure which causes the product to become unfit for its intended use, subject to normal usage and installation, for a period of 1 year from the date of shipment to the original customer.

### LIMITED WARRANTY ON SITE FURNISHINGS

Manufacture provides a five-year limited warranty on the finish of thermoplastic coated site furnishings from the date of shipment to the original customer. Additionally, all site furnishings are guaranteed to be free from defects in materials or workmanship for one-year from the date of shipment to the original customer.

All warranties specifically exclude damage caused by man-made or natural disasters, vandalism, negligence, improper installation or improper use, modification, changes in appearance resulting from weathering, scratches, dents, discoloration, normal wear and tear, or marring as a result of public or private use. Claims are limited to replacement of equipment only and do not include any costs associated with labor, removal or installation of the original or replacement product. Warranties are valid only if products are installed and maintained in accordance with installation instructions and use of approved parts. This warranty is applicable to the original owner only. Warranties are non-transferable.

## CLAIM PROCEDURE

Claim Procedure: To make a warranty claim, send your written statement of claim, photographs of defective equipment, and the original order or invoice number to:

Within 60 days of notice of claim under warranty, manufacture will make arrangements to replace the damaged product. Manufacture will cover freight costs within the continental United States. Manufacture is not responsible for freight costs associated with products located outside the continental United States. Manufacture reserves the right to inspect all products identified as defective. Photos of defective equipment may be required to accompany warranty claims. Since warranty limitations and exclusions may vary from state to state, you should check any specific warranty rights in your state.

Date of Purchase: \_\_\_\_\_

Purchaser: \_\_\_\_\_

Invoice Number: \_\_\_\_\_



Consider these freestanding play components to enhance the fun of your play environment!

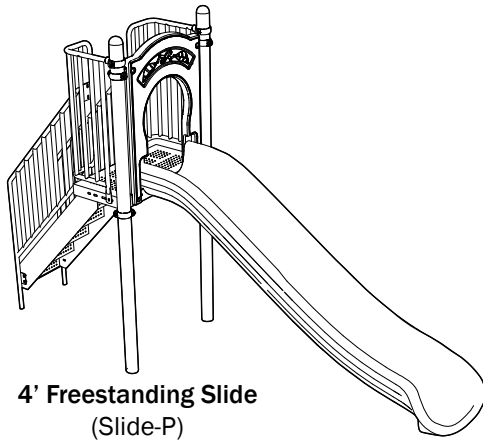

4' Freestanding Slide  
(Slide-P)

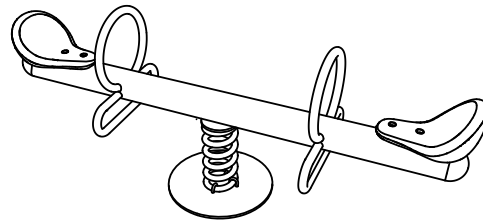

Spring See Saw  
(02-07-0055)

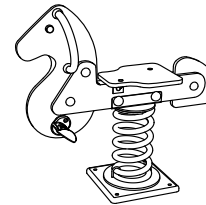

Horse Spring Rider  
(02-07-0053)

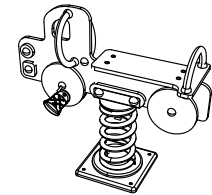

Truck Spring Rider  
(02-07-0054)

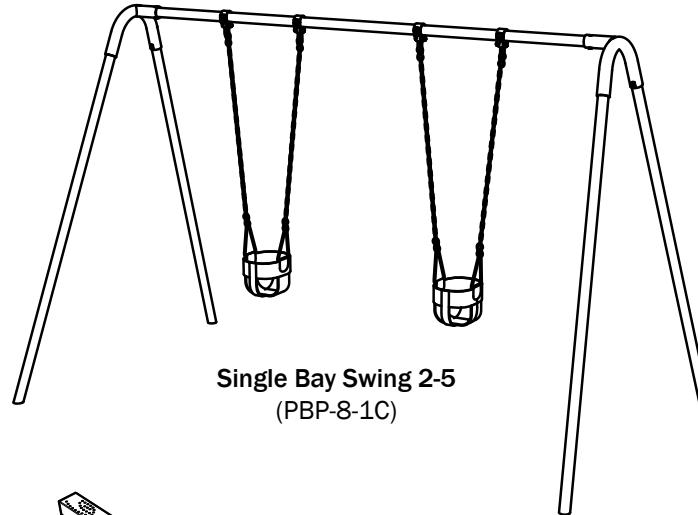

Single Bay Swing 2-5  
(PBP-8-1C)



Early Childhood  
Horizontal Ladder  
(PJHLAD)

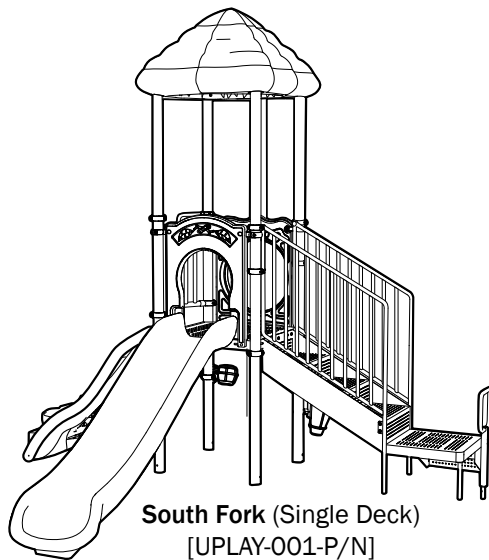

South Fork (Single Deck)  
[UPLAY-001-P/N]

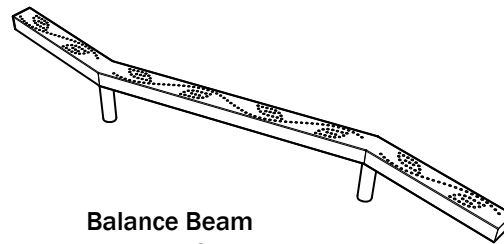

Balance Beam  
(ZBAL-8)

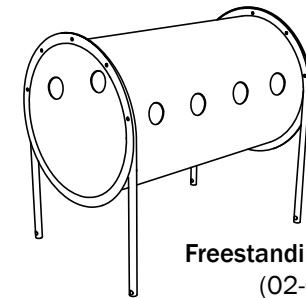

Freestanding Crawl Tunnel  
(02-07-0057)

## GENERAL INSTALLATION GUIDELINES (Page 1 of 4)

**IMPORTANT! Please read the entire Installation Instructions packet before beginning the installation.**

The manufacture has designed Discovery Centers to take advantage of all Consumer Product Safety Commission (CPSC) and ASTM guidelines in force at the time of purchase in an effort to prevent playground accidents. However, because studies have shown most playground injuries result from accidental falls, you, as the new owner of this equipment are responsible for providing an adequately resilient play surface under and around all playground equipment. Please refer to the accompanying Safety Guidelines as well as CPSC guidelines and this document for examples of such surfacing.

We would like to provide the following suggested guidelines for your play environment:

- Refer to the **Use Zone** and note the Minimum Area Required shown for this structure. This area must be filled with adequate resilient play surface material, and must be clear of all obstacles, including but not limited to trees, curbing, sidewalk, fence, other play equipment, rocks and landscaping, etc.
- Acceptable play surfaces include sand, mulch, fine gravel or shredded belt-less tires, if installed at the appropriate depths per CPSC guidelines for play surfacing.
- When using loose fill surfacing, a minimum of 6" depth is recommended by the CPSC. Manufacture recommends an additional 6", for a total of 12", to combat the fast compacting characteristics of these materials. Surfaces must be checked at least weekly for compacting, which reduces resiliency significantly.
- Unitary resilient surfacing designed for playground use, including rubber tiles, poured-in-place rubber surfacing, bonded rubber surfacing and synthetic playground turf is also recommended.
- Surfaces such as asphalt, concrete, gravel, or sod are not acceptable for use under playground equipment, or anywhere within the stated Minimum Area Required.
- Close supervision of children playing on or around the structure is strongly recommended, along with classroom and/or home instructions on safer behavior on the playground equipment. The full supervision of playgrounds is the responsibility of the owner once the play structure has been properly installed.

## GENERAL INSTALLATION GUIDELINES (Page 2 of 4)

### TOOLS REQUIRED:

UltraPlay supplies only the special wrenches and bits required to fasten the “tamper-resistant” hardware and components. Refer to the **Tools Required** page for a detailed list. A power post hole digger may facilitate installation in some circumstances.

1. Compare all parts received to the packing list. Notify UltraPlay immediately of any missing parts. We are not responsible for parts discovered missing over 10 days after receipt of the shipment.
2. Refer to the Use Zone to ensure this structure will fit into your actual site area. Note the Minimum Area Required measurements to determine clear space required. A minimum of 6' clearance is required between any obstacles and your structure. EXCEPT for slide exits, which require a distance X equal to the highest point of sliding surface with a minimum of 6' and a maximum of 8' from the edge of the slide (example: A Slide from a 6' high deck requires 6' of clear space with resilient surfacing in front of its exit).
3. Site selection should include considerations of what is a safer and appropriate play area:
  - A level and clear site is ideal, free of power lines or electrical equipment.
  - Do not install play equipment near any bodies of water.
  - If adjacent to a street with traffic, ensure adequate fencing acts as a barrier to children running into danger.
4. Site layout should include accurate measurement and marking of all footings prior to any installation. Use the dimensions shown between footings on the Use Zone to plot out the actual footprint of the play structure before doing any digging. Also locate any free-standing play equipment in the same way, providing the necessary clearance between the equipment as well as any fences, trees, etc. Ensure at this time you have enough total space for the equipment to be installed.
5. If using Inground footers, excavate holes as shown in the Use Zone using a string line. An optional string line level is very helpful. If a level and clear site is not possible, adjust the depth of the footings to maintain a minimum depth of 18" for support posts at the lowest grade. NOTE: If soil conditions are very loose or otherwise unstable, a larger diameter footing may be required. Inquire with local contractors for appropriate recommendations.
6. Begin your Discovery Centers installation by erecting the decks as shown within the following instructions. Once all decks are installed, components such as slides, climbers, etc., can be connected per their respective assembly instructions.
7. CPSC guidelines mandate that there shall be no gaps present in the playground equipment that are between 3-1/2" and 9".

## GENERAL INSTALLATION GUIDELINES (Page 3 of 4)

The positioning of certain components by the installer can affect these criteria, so you should always measure distances created when attaching components in order to avoid these spaces which can cause entrapment of a child using the equipment. Also, ASTM requires that no more than 2 threads of a bolt can protrude from the nut. Any excess threads should be filed down and made smooth to the touch.

8. When concrete is poured, be sure to keep the top 4" below the grade, and sloped away from the post to promote good water drainage. Wash off any concrete, that may have splashed onto the post before it dries. Allow all concrete to harden a minimum of 48 hours before allowing use.

### **SAFETY DURING INSTALLATION:**

1. Before doing any excavation, inquire about any existing underground utilities.
2. Do not leave the job site unattended without making sure that all fastening hardware on all equipment are tightened. It is also strongly recommended that all installation areas be roped off with clearly marked warning signs posted. Any open footings should be covered with plywood or other suitable material. Even during installation, it has been found that children may attempt to use the unattended equipment, thereby risking accidents.
3. If concrete footings and inground footers are being used, it is strongly recommended that the installation area should remain roped off for at least 48 hours after the last concrete footing is poured. Children should not be allowed to use the equipment during this period so that concrete has a chance to fully cure.
4. Do not attach swing chains or similar moving components until after all construction is complete and resilient surfacing material has been installed. Remember that any equipment, which appears to be complete and functional, will invite unauthorized use regardless of its actual state of readiness.

Finally, if you should have any questions regarding the proper installation of this equipment, please contact UltraPlay at:

UltraPlay  
Discovery Centers Customer Service  
1675 Locust Street, Red Bud, IL 62278  
Phone: 1-800-458-5872 • Fax: 1-618-282-8202  
E-mail: [customerservice@uplaytoday.com](mailto:customerservice@uplaytoday.com)

800.458.5872 • [www.ultraplay.com](http://www.ultraplay.com)

The Discovery Center is a modular play system that uses a grid system for the playground layout. It is very important to spend a few minutes before beginning the installation to ensure that components are inventoried and organized properly. **INVENTORY MUST BE TAKEN PER CARTON!**

### **LOOK FOR THE NUMBERS!**

Each metal post will have a NUMBER sticker on it that corresponds with the numbers on the printed grid. Some grid numbers have an UPPER level post as well as a LOWER level post. All of the LOWER level posts have ground mounting plates welded to them. The UPPER level posts do not. The UPPER and LOWER posts will have matching numbers.

The UPPER level posts screw into the LOWER level posts using the “T” tool provided (see *tools page*).

The plastic components all have numbers on them that correspond with the grid and post numbers. This will enable you to verify that the correct component is installed in the correct location. When installing the plastic post covers, simply match up the numbers on the plastic with the numbers on the vertical posts.

# TOOLS REQUIRED

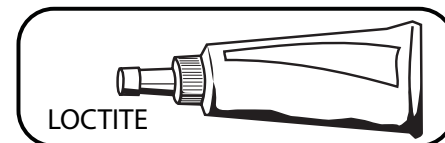
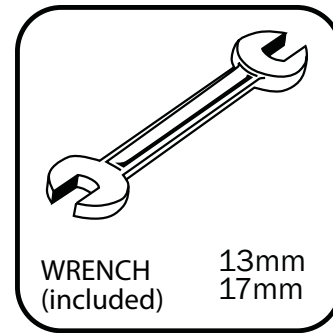
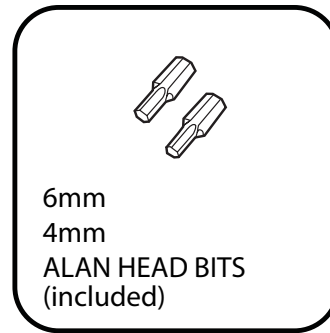
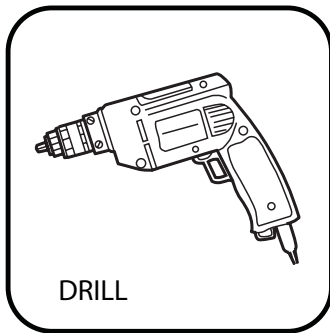
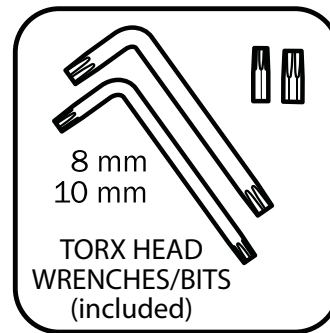
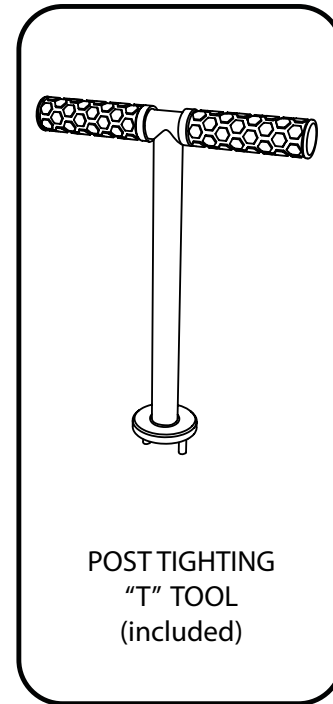
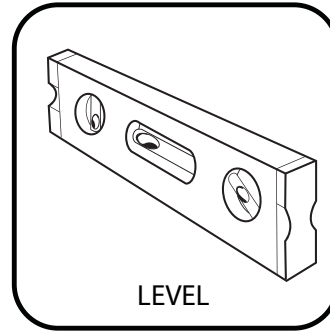
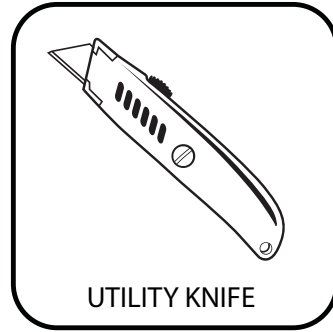

# HARDWARE REFERENCE

NOTE: Your play structure may not use all hardware listed

## M10 B.H.C.S. Bolts

13mm	20mm	25mm	30mm	35mm	40mm	45mm	50mm	60mm	70mm	80mm
1/2"	3/4"	1"	1-3/16"	1-3/8"	1-9/16"	1-3/4"	2"	2-3/8"	2-3/4"	3-1/8"
33-11-0001	33-11-0002	33-11-0003	33-11-0004	33-11-0005	33-11-0006	33-11-0113	33-11-0010	33-11-0007	33-11-0008	33-11-0011

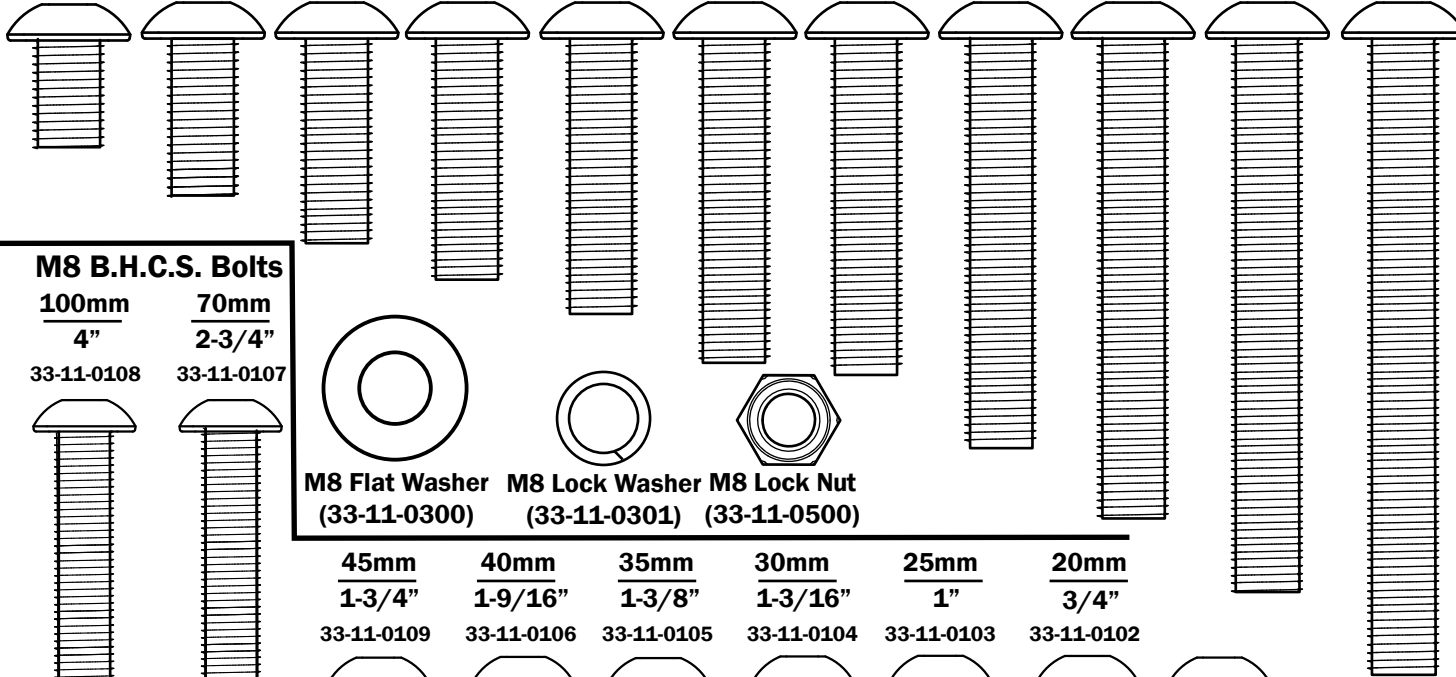

## M8 B.H.C.S. Bolts

100mm	70mm
4"	2-3/4"
33-11-0108	33-11-0107

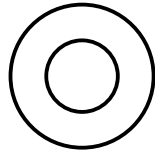
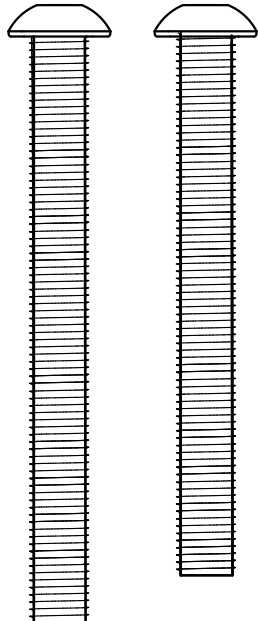

M8 Flat Washer (33-11-0300)

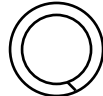

M8 Lock Washer (33-11-0301)



M8 Lock Nut (33-11-0500)

45mm	40mm	35mm	30mm	25mm	20mm
1-3/4"	1-9/16"	1-3/8"	1-3/16"	1"	3/4"
33-11-0109	33-11-0106	33-11-0105	33-11-0104	33-11-0103	33-11-0102

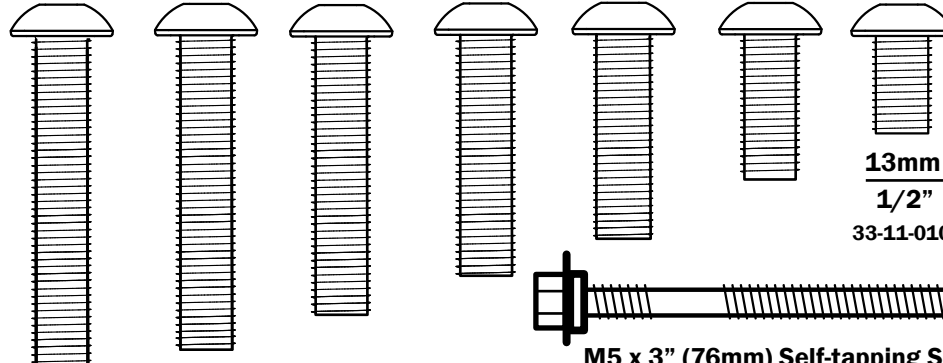

## Extra Hardware

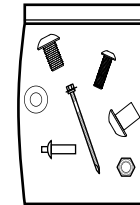

13mm  
1/2"  
33-11-0101

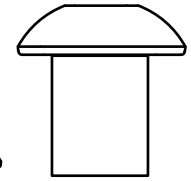

M10 Barrel Nut (33-11-0401)

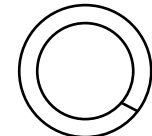

M10 Lock Washer (33-11-0201)

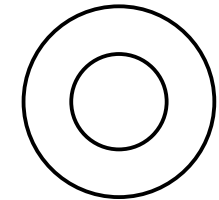

M10 Flat Washer (33-11-0200)

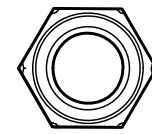

M10 Lock Nut (33-11-0400)

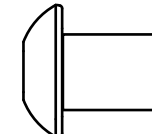

M8 Barrel Nut (33-11-0501)

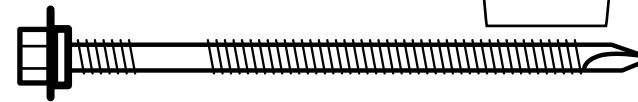

M5 x 3" (76mm) Self-tapping Screw (33-11-0600)

18" Ground Spike (02-07-0048) (not to scale)

# USE ZONE

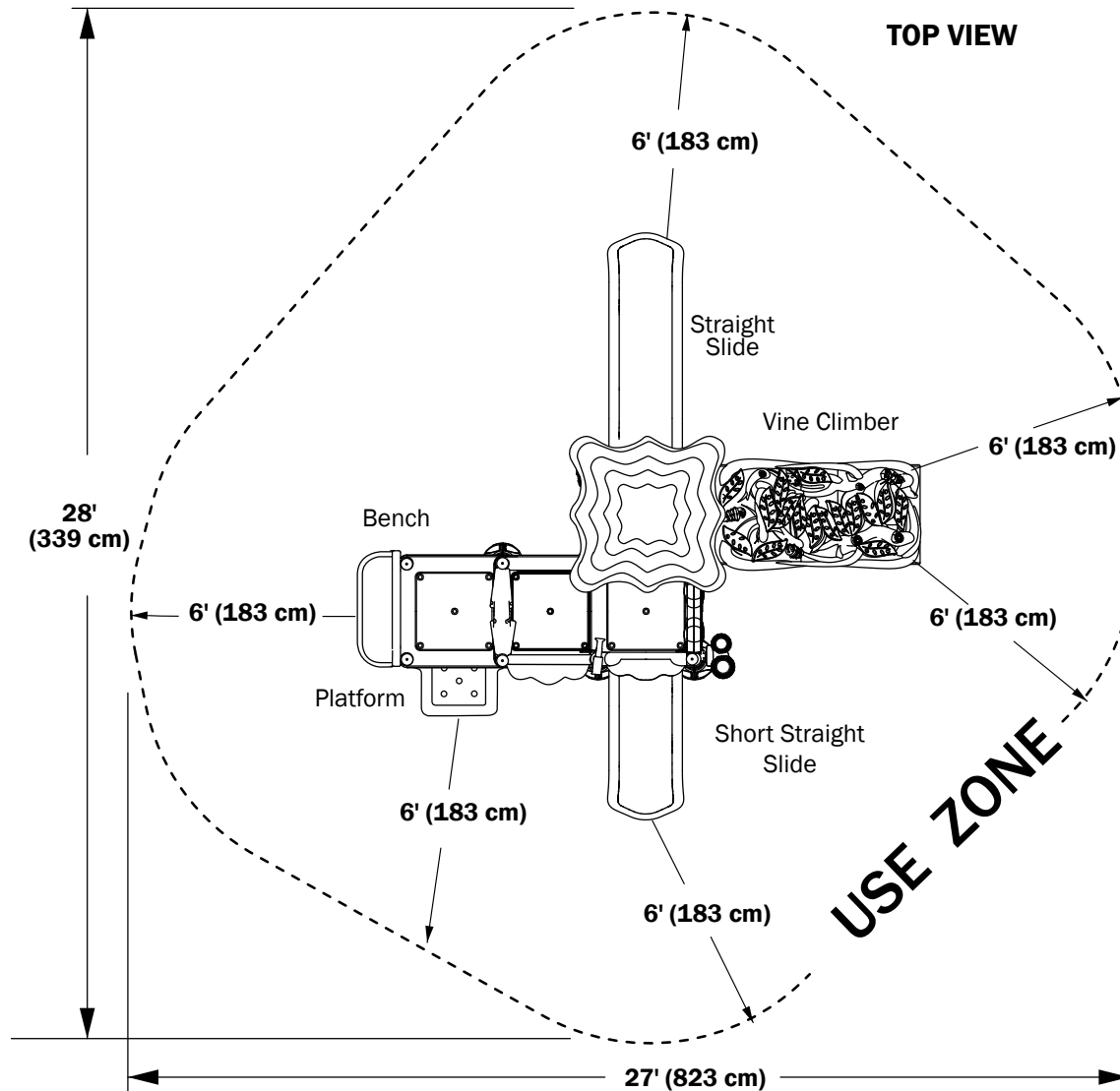

## MINIMUM USE ZONE\* REQUIRED

\* The USE ZONE is the area beneath and immediately adjacent to a play structure or equipment that is designed for unrestricted circulation around the equipment and on whose surface it is predicted that a user would land when falling from or exiting the equipment.

### NOTE:

Equipment shall be positioned to eliminate conflicting traffic patterns. As a general rule, allow at least 6' of freespace around the entire structure.

**IMPORTANT:** Never install play equipment over hard, unresilient surfaces such as asphalt, concrete or compacted earth. It is the owner's responsibility to ensure the "minimum area required" contains an appropriate amount of resilient material to cushion accidental falls.

INSTALLED DIMENSIONS	
DC-4LG	16ft wide x 15ft long x 10ft 6in tall



# POST PLACEMENT/HOLE LOCATIONS

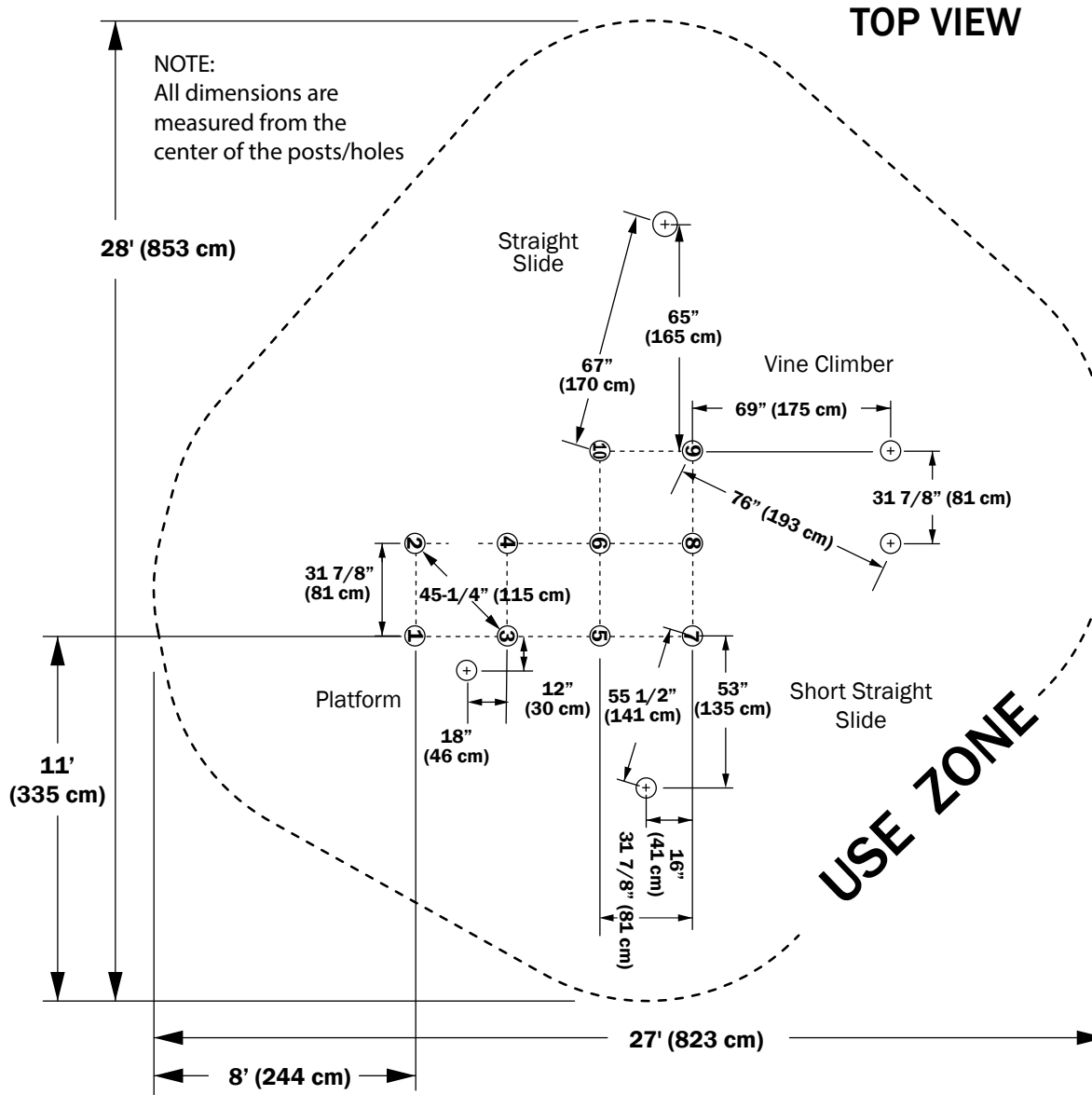

**IMPORTANT:** Never install play equipment over hard, unresilient surfaces such as asphalt, concrete or compacted earth. It is the owner's responsibility to ensure the "minimum area required" contains an appropriate amount of resilient material to cushion accidental falls.

 Placement for 12" Diameter x 18" Deep Holes for In-ground installation

**1 All Posts are numbered**

1. Review Use Zone. Begin placement of Deck Post 1.

**NOTE: Survey flags may be used to mark the placement of each hole.**

2. Measure from first Deck Post to mark the position of the remaining posts/holes. Check for squareness using the 45-1/4" diagonal dimension.

**NOTE: All remaining dimensions are based off of the Deck Post placement.**

3. Measure from the center of a Deck Post using the dimensions provided for each remaining hole.

**Concrete Required**(if applicable) :  
Approx. .7 Cubic Yards (.5 Cubic Meters)  
**NOTE:** Suggested Min. concrete rating: 3000PSI

# DECK PLACEMENT

## TOP VIEW

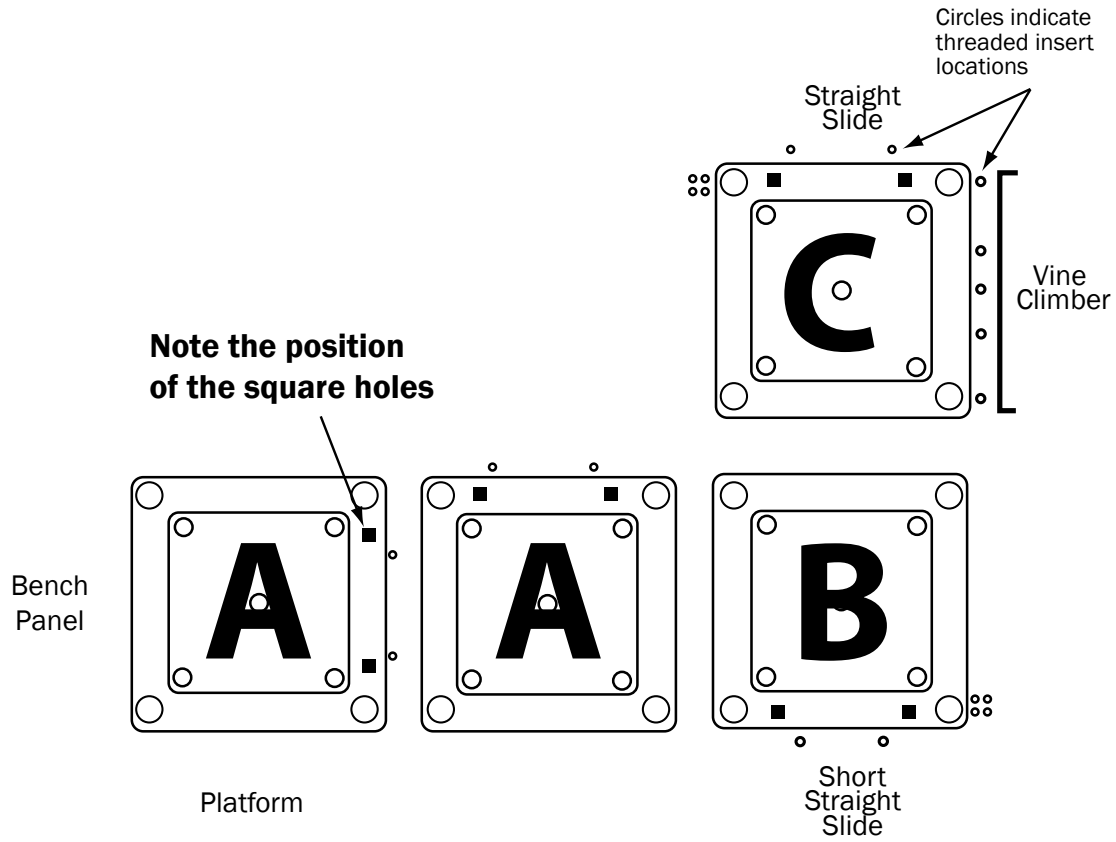

## DECK DETAIL

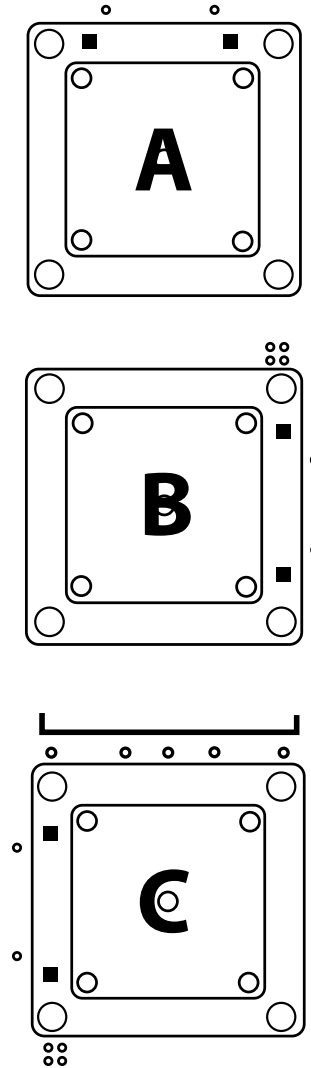

# FOOTING DETAIL - GROUND SPIKES (Hardware Kit #02-08-0206)

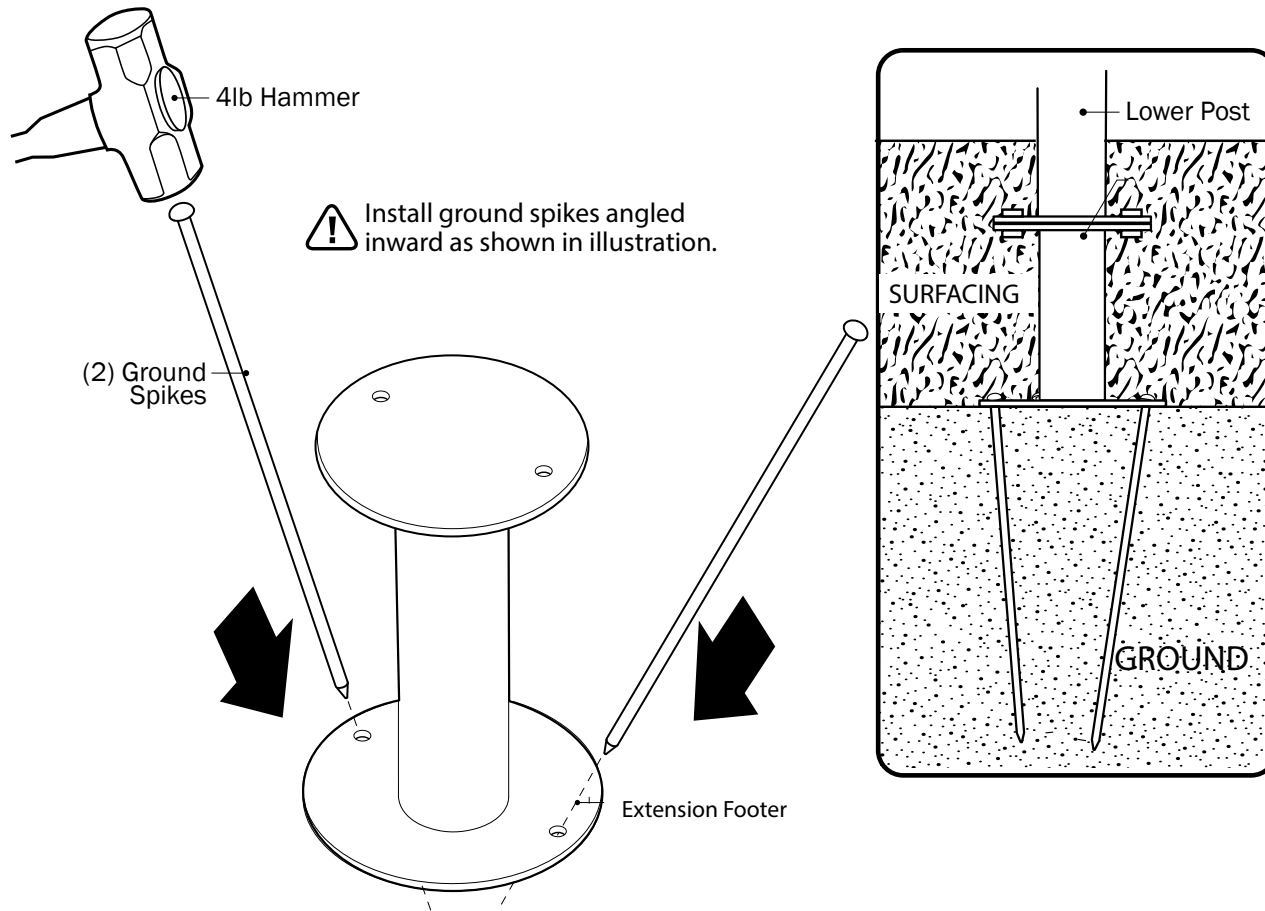

## Instructions:

1. With Footers in position, secure each footer to the ground using (2) ground spikes.

NOTE: A 4 lb. hammer may be required to drive spikes into the ground.

2. Install Engineered Wood Fiber surfacing to a depth of 12".

NOTE: 12" Engineered Wood Fiber will typically settle to a 9" depth.

NOTE:  
illustration depicts 8"  
(203mm) Extension Footer

Installation of 2"(51mm)  
Extension Footer is similar.

**IMPORTANT:** Never install play equipment over hard, unresilient surfaces such as asphalt, concrete or compacted earth. It is the owner's responsibility to ensure the "minimum area required" contains an appropriate amount of resilient material to cushion accidental falls.



## ! SITE PREPARATION

Clear area of any debris and level surface. Equipment is designed to be installed on a level surface.

# FOOTING DETAIL - CONCRETE ANCHORS (Hardware Kit #02-08-0207)

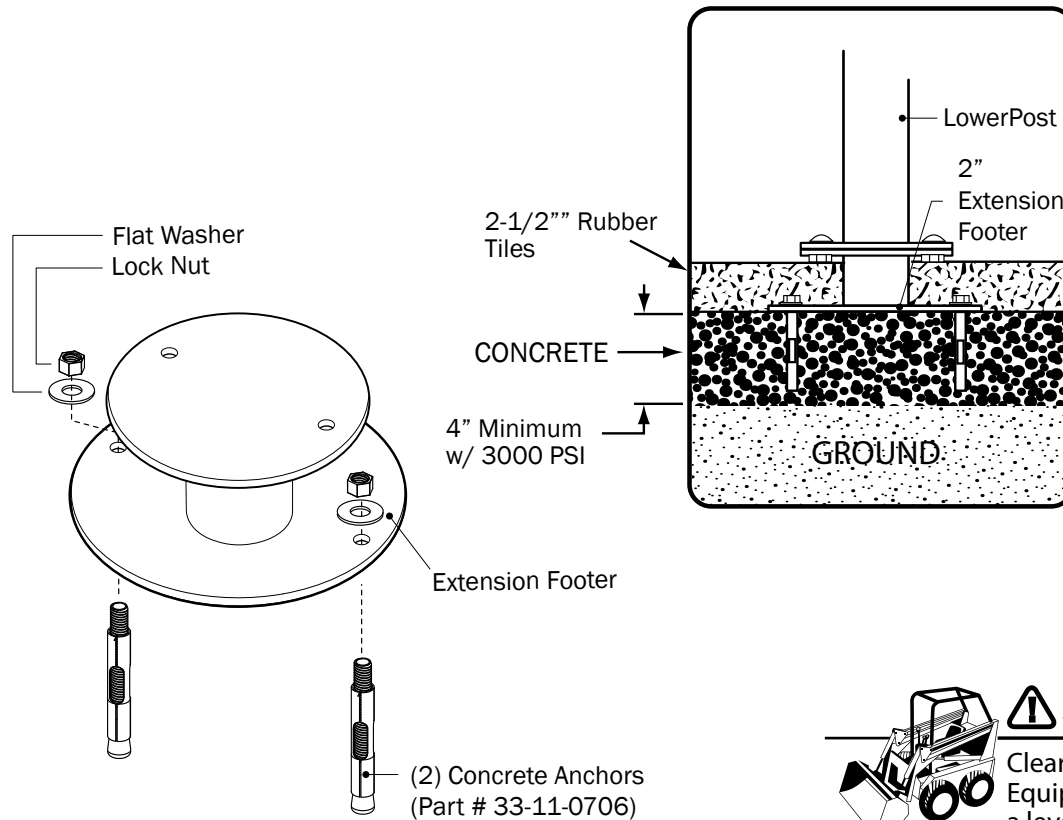

## Instructions:

1. With Extension Footer in position, mark hole position. Remove Extension Footer and drill (2) 3/8" Dia. x 2" deep holes into concrete to receive anchor.
2. Insert Concrete Anchors and secure with Flat Washer and Lock Nut.



## ⚠ SITE PREPARATION

Clear area of any debris and level surface. Equipment is designed to be installed on a level surface.

**IMPORTANT:** Never install play equipment over hard, unresilient surfaces such as asphalt, concrete or compacted earth. It is the owner's responsibility to ensure the "minimum area required" contains an appropriate amount of resilient material to cushion accidental falls.

# FOOTING DETAIL - INGROUND FOOTERS (Hardware Kit #02-08-0208)

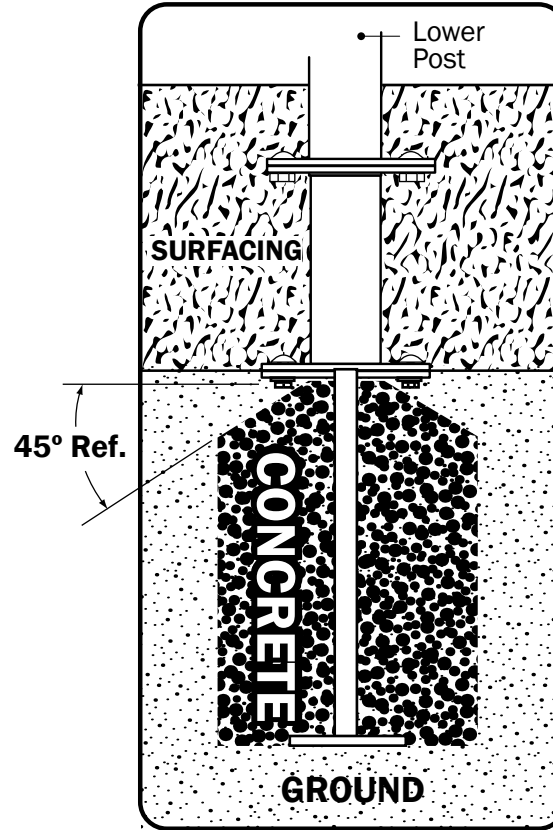
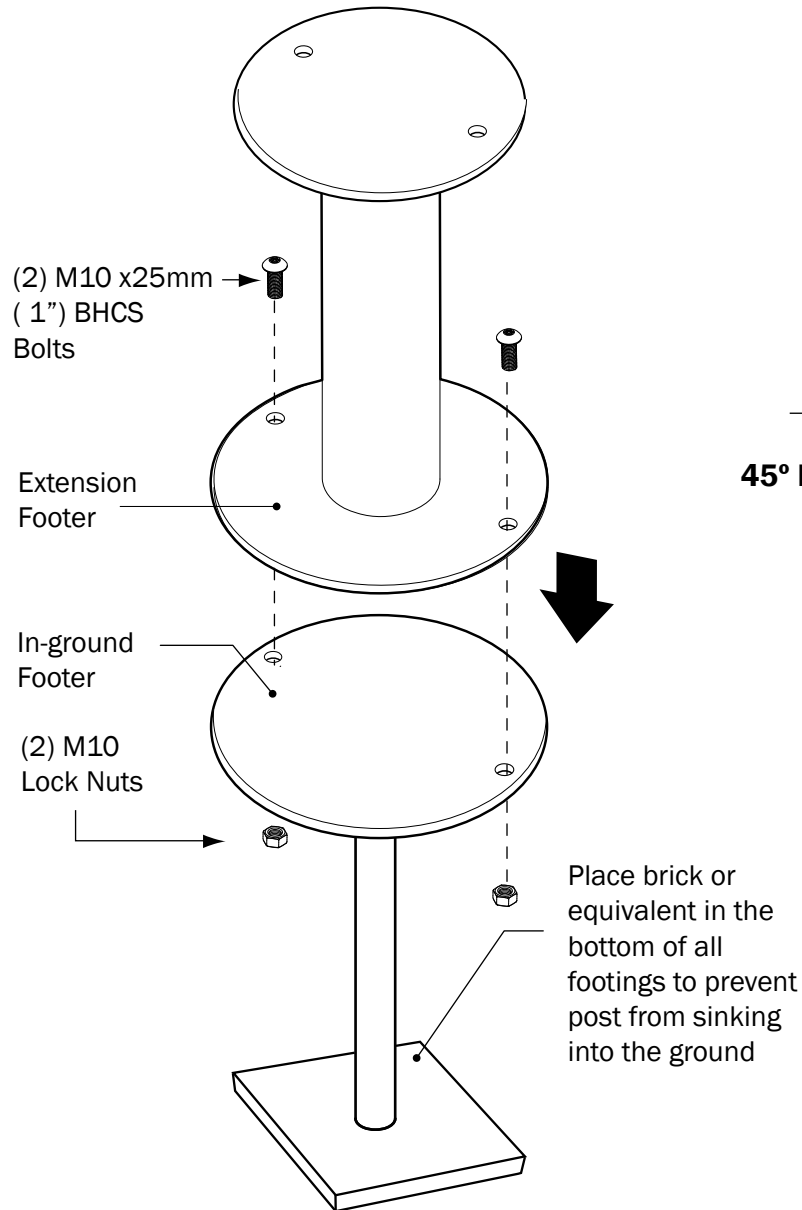

## Instructions:

1. Bolt Extension Footer and Inground Footer together using ( 2 ) M10 x 20mm ( 3/4" ) BHCS Bolts and ( 2 ) M10 Lock Nuts.

Refer to *Hole/Footer Location* on page 5 of these instructions.

## NOTE:

illustration depicts **8" (203mm) Extension Footer. Installation of 2"(51mm) Extension Footer is similar.**

**IMPORTANT:** Never install play equipment over hard, unresilient surfaces such as asphalt, concrete or compacted earth. It is the owner's responsibility to ensure the "minimum area required" contains an appropriate amount of resilient material to cushion accidental falls.

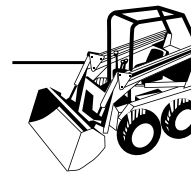

## ⚠ SITE PREPARATION

Clear area of any debris and level surface. Equipment is designed to be installed on a level surface.

# STEP 1 - CONNECT FOOTERS TO LOWER POSTS

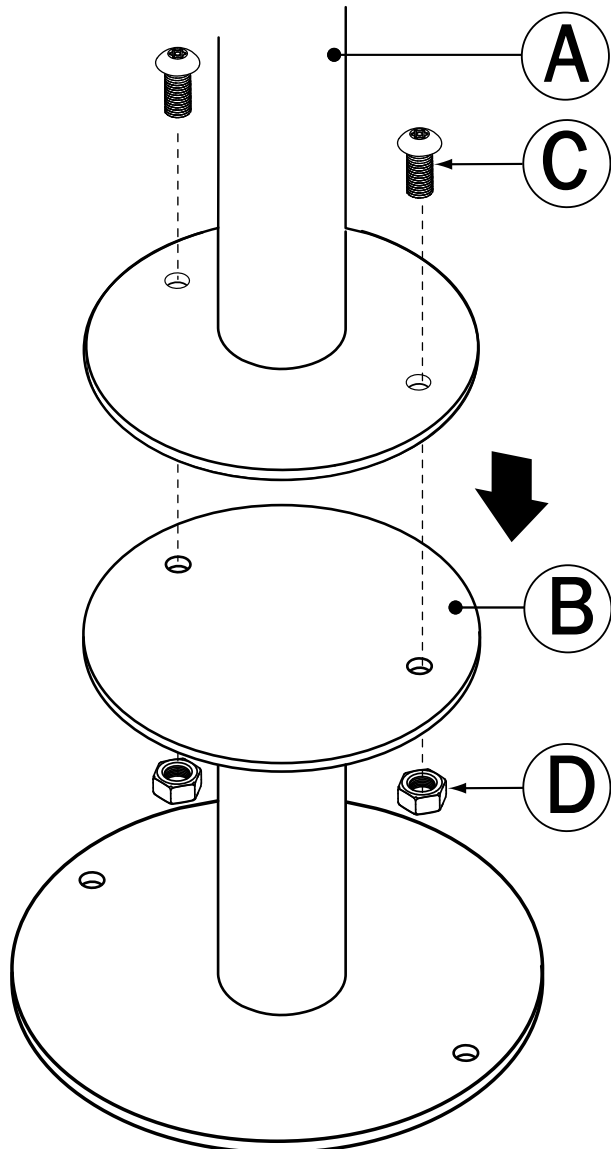

Figure 1.

Parts List			
Letter	Description	Quantity	Part Number
A	Lower Posts	10	ALL
	<b>Hardware Complete</b>	See Footing Detail Pages	
B	Footer - 8"*	10	02-08-0134
B	Footer - 2"*	10	02-08-0135
C	M10 x 25mm(1") BHCS Bolt	20	33-11-0003
D	M10 Lock Nut	20	33-11-0400

\*(10) Inground Footers included in hardware kit (02-08-0208) for inground applications. See Page 22.

NOTE: Refer to USE ZONE page for proper structure placement before beginning installation process.

1. Locate Lower Posts(A).

**NOTE: Lower Posts are identified by number decals**

2. Connect Extension Footer(B) to Lower Post(A) using (2) Bolts(C) and (2) Lock Nuts(D). See Figure 1.

**NOTE: 8" Extension Footer(B) shown in illustration. Use 2" Extension Footer for 2-1/2" rubber tiles**

3. Repeat Step 2 for remaining Lower Posts(A).

**NOTE: If installing Discovery Center with concrete footers, install In-ground footers at this time. See Footing Detail on Page 22 .**

## STEP 2 - CONNECT PLATFORM MOUNTING BRACKET TO PLATFORM

Parts List			
Letter	Description	Quantity	Part Number
A	Platform	1	02-08-0022
B	Platform Mounting Bracket	1	02-08-0120
	<b>Hardware Complete</b>	1	33-12-1008
C	M10 x 25mm( 1") BHCS Bolt	2	33-11-0003
D	M10 Lock Washer	2	33-11-0201
E	M10 Flat Washer	2	33-11-0200

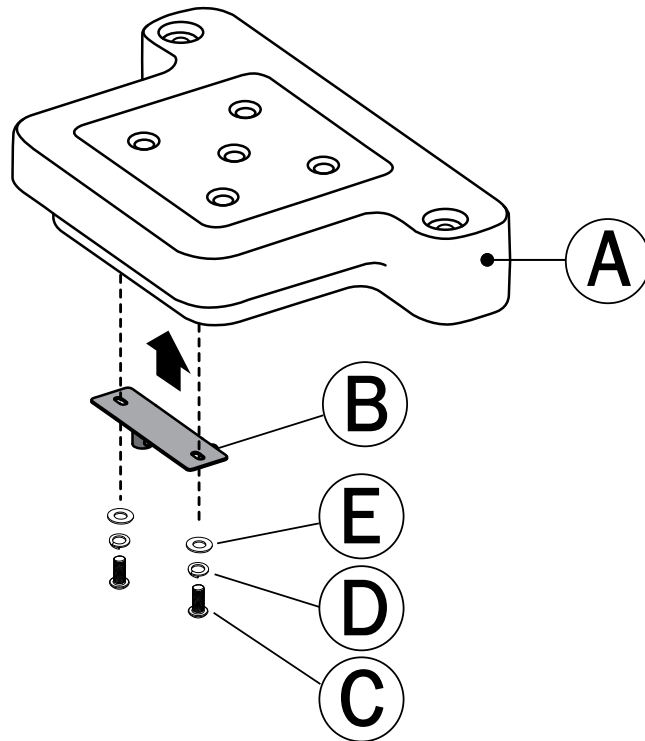

1. Align holes in underside of Platform(A) with slots in Platform Mounting Bracket(B).
2. Insert Bolts(C), Lock Washers(D) and Flat Washers(E) into slots in Platform Mounting Bracket(B) and into threaded inserts on underside of Platform(A).

**Note: Insert both Bolts(C) into Platform(A) before tightening.**

# STEP 3 - ATTACH EXTENSION POSTS AND FOOTER PLATES TO PLATFORM

Parts List			
Letter	Description	Quantity	Part Number
A	Extension Post	1	02-08-0118
B	Footer Plate	1	02-08-0122
	<b>Hardware Complete</b>	1	33-12-1008
C	M10 x 35mm(1-3/8") BHCS Bolt	2	33-11-0005
D	M10 Lock Nut	2	33-11-0400



Footer Plate (B)

### FRONT VIEW

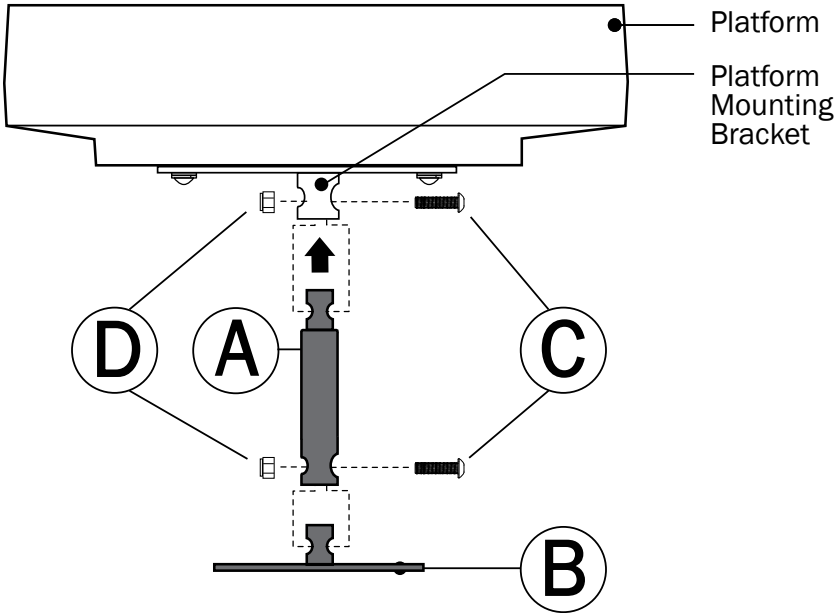

1. Insert Extension Post(A) into shaft of Platform Mounting Bracket and align holes.
2. Insert Bolt(C) through larger hole in shaft of Platform Mounting Bracket and secure with Lock Nut(D).
3. Insert Footer Plate(B) into Extension Post(A) and align holes.
4. Insert Bolt(C) through larger hole in Extension Post(A), through hole in Footer Plate(B) and secure with Lock Nut(D).



## STEP 4 - CONNECT BENCH PANEL AND PLATFORM TO DECK 1

Parts List			
Letter	Description	Quantity	Part Number
A	Bench Panel	1	02-08-0010
B	Deck A	1	02-08-0006
C	Lower Post Cover -7.5" Long	1	02-08-0050
Number			
1,2	Lower Post - 17.32" Long	2	02-08-0109
3	Lower Post - 73.75" Long	1	02-08-0113
4	Lower Post - 47.2" Long	1	02-08-0112

1. Place Bench Panel(A) on its side.
2. Push Deck(B) against back side of Bench Panel(A).

**NOTE: Deck(B) will be placed between protrusions on right side and under protrusion on the left side of Bench Panel(A).**

3. Align holes in Bench Panel(A) and Deck(B).  
Insert Lower Post #2 through bottom protrusion of Bench Panel(A), through Deck(B) and into top protrusion of Bench Panel(A).
4. Insert Lower Post #1 through left hole in Platform, into upper left hole in Deck(B) and into top protrusion of Bench Panel(A).
5. Insert Lower Post #3 into right hole in Platform and through upper right hole in Deck(B).
6. Insert Lower Post #4 through Lower Post Cover(C) and through bottom right hole in Deck(B).
7. While supporting Lower Posts(1,2,3,4), place assembled parts into upright position.

 **There are (3) Deck variations(A,B & C) See Deck Placement Page for proper placement on Page 19.**

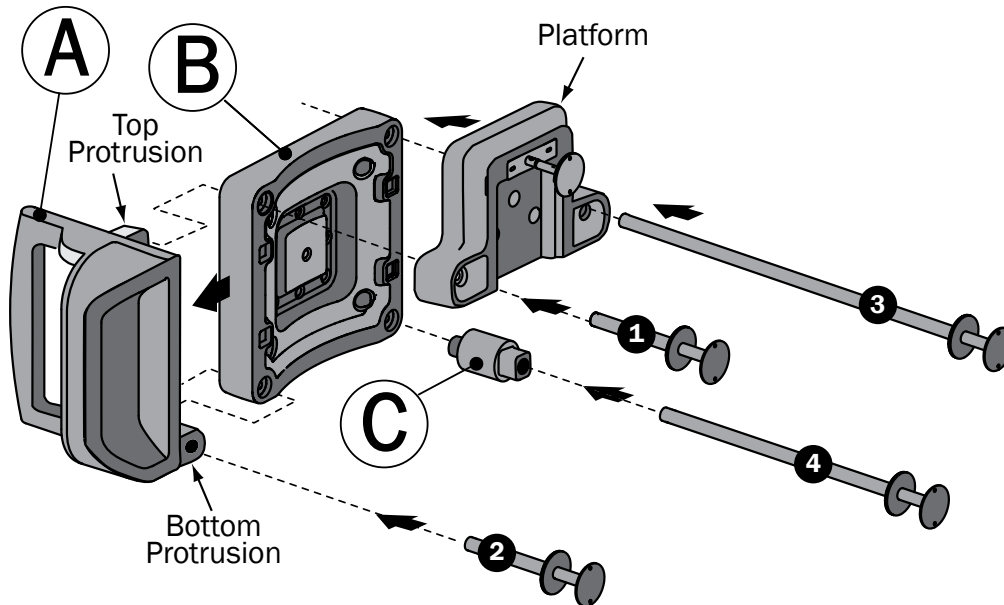

## STEP 5 - INSTALL DECK 2

Parts List			
Letter	Description	Quantity	Part Number
A	Lower Post Cover - 15.38"	2	02-08-0028
B	Deck A	1	02-08-0006
Number			
5	Lower Post - 31.5" Long	1	02-08-0110
6	Lower Post - 39.4" Long	1	02-08-0111

1. Place Lower Posts #5 and #6 in approximate position.
2. Slide Lower Post Covers(A) downward onto Lower Posts #5 and #6.
3. Align holes in Deck(B) with Lower Posts and push downward so that Deck(B) rests onto Deck and Lower Post Covers(A).



**Make sure square holes on top surface of Deck are in the proper location.**



**There are (3) Deck variations (A,B & C) See Deck Placement Page for proper placement on Page 19.**

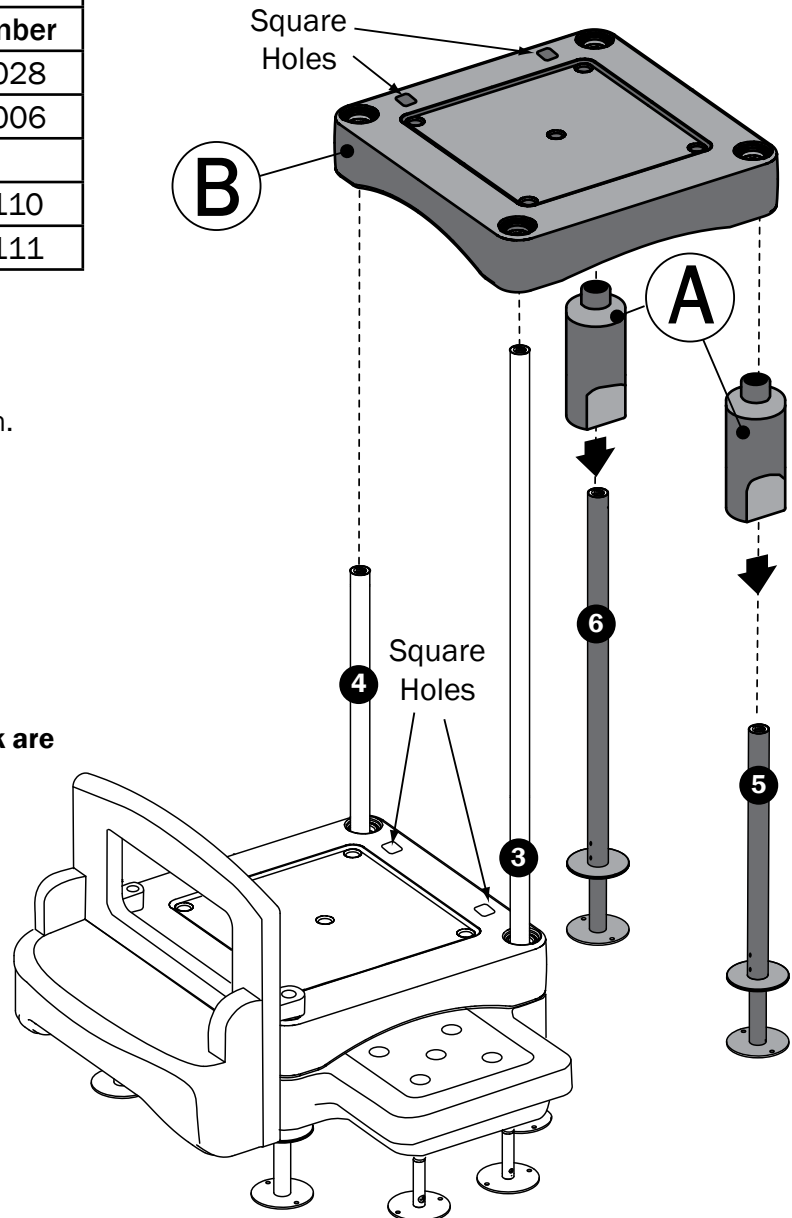

# STEP 6 - INSTALL DECK 3

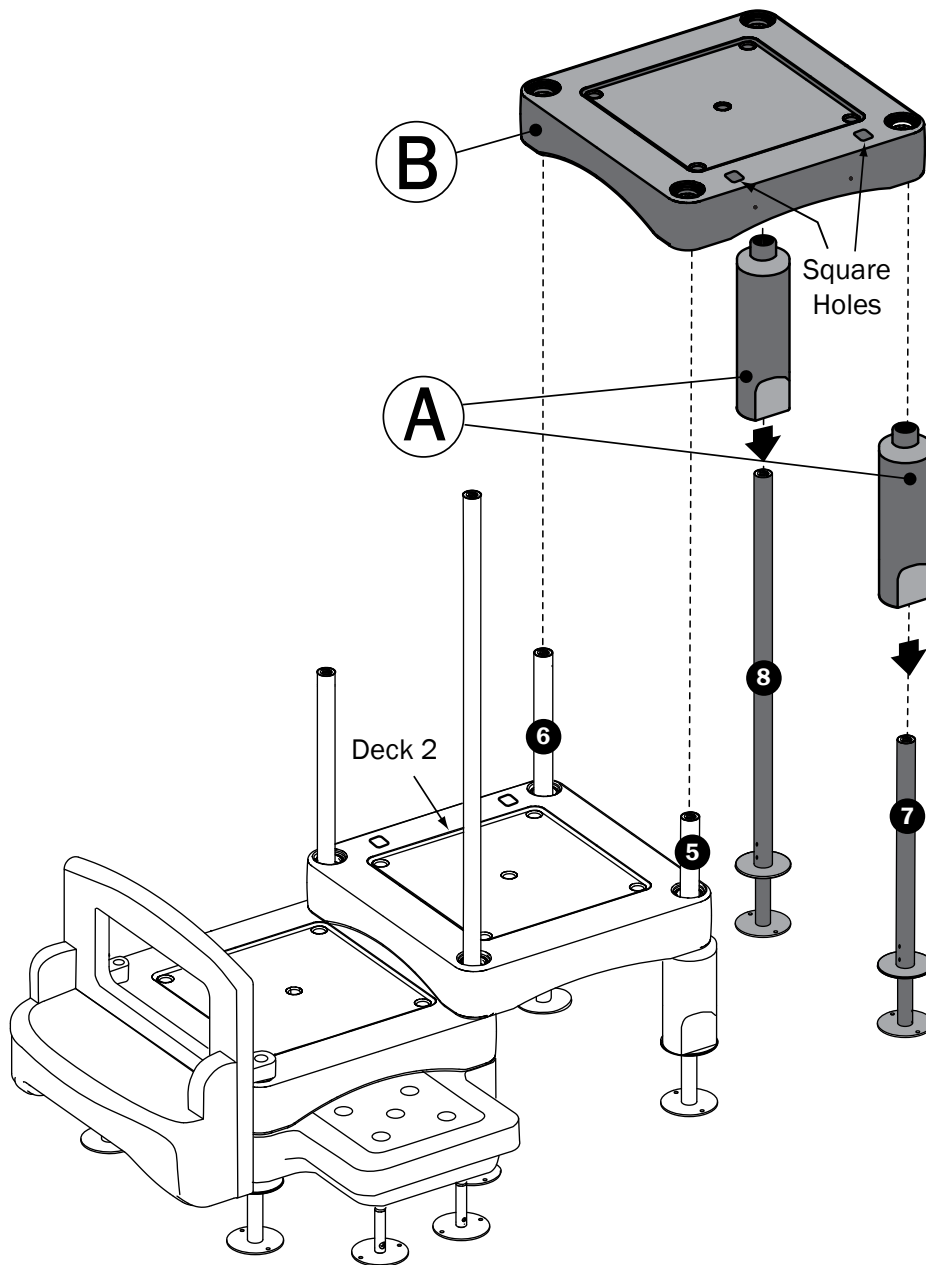

Parts List			
Letter	Description	Quantity	Part Number
A	Lower Post Cover - 22.88"	2	02-08-0029
B	Deck B*	1	02-08-0041
Number			
7	Lower Post - 31.5" Long	1	02-08-0110
8	Lower Post - 73.62" Long	1	02-08-0113

1. Place Lower Posts #7 and #8 in approximate position.
2. Slide Lower Post Covers(A) downward onto Lower Posts #7 and #8.
3. Align holes in Deck(B) with Lower Posts #5, #6, #7 and #8 push downward so that Deck(B) rests onto Deck 2 and Lower Post Covers(A).

**!** Make sure square holes on top surface of Deck are in the proper location.

**!** There are (3) Deck variations(A,B & C) See Deck Placement Page for proper placement on Page 19.

## STEP 7 - INSTALL DECK 4

Parts List			
Letter	Description	Quantity	Part Number
A	Lower Post Cover - 30.25"	2	02-08-0030
B	Deck - C	1	02-08-0042
Number			
9,10	Lower Post - 39.4" Long	2	02-08-0111

1. Place Lower Posts #9 and #10 in approximate position.
2. Slide Lower Post Covers(A) downward onto Lower Posts #9 and #10.
3. Align holes in Deck(B) with Lower Posts #6, #8, #9 and #10 and push downward so that Deck(B) rests onto Deck and Lower Post Covers(A).

 **Make sure square holes on top surface of Deck are in the proper location.**

 **There are (3) Deck variations(A,B & C)  
See Deck Placement Page for proper placement on Page 19.**

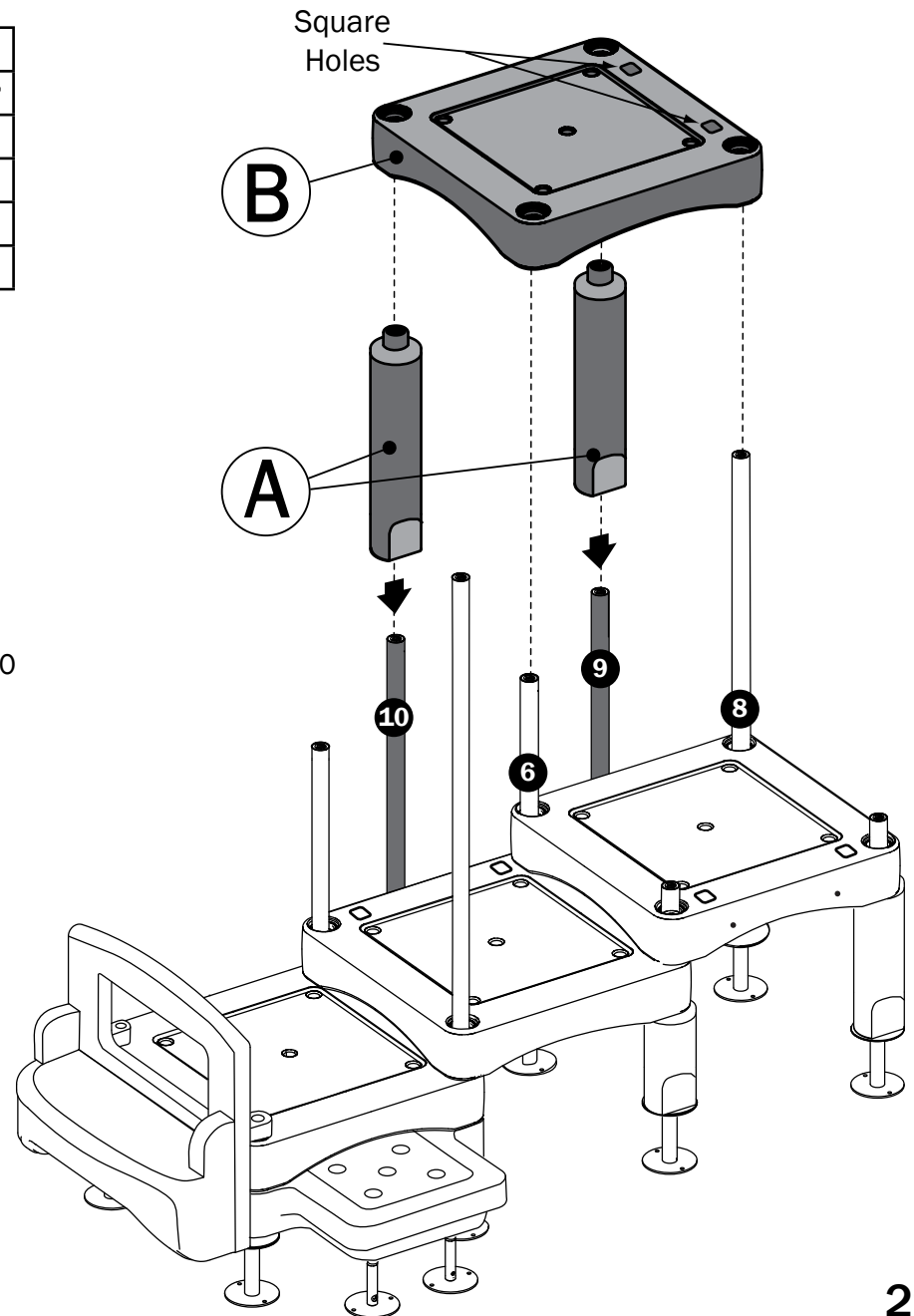

## STEP 8 - INSTALL TOUCHMATH PANEL

Parts List			
Letter	Description	Quantity	Part Number
A	TouchMath Panel w/ Inserts	1	02-08-0047
B	Upper Post Covers - 7.38" Long	2	02-08-0033

1. Place (2) Upper Post Covers(B) between wings on left side of Touchmath Panel(A) while lowering Touchmath Panel(A) onto Lower Posts(#3 and #5).

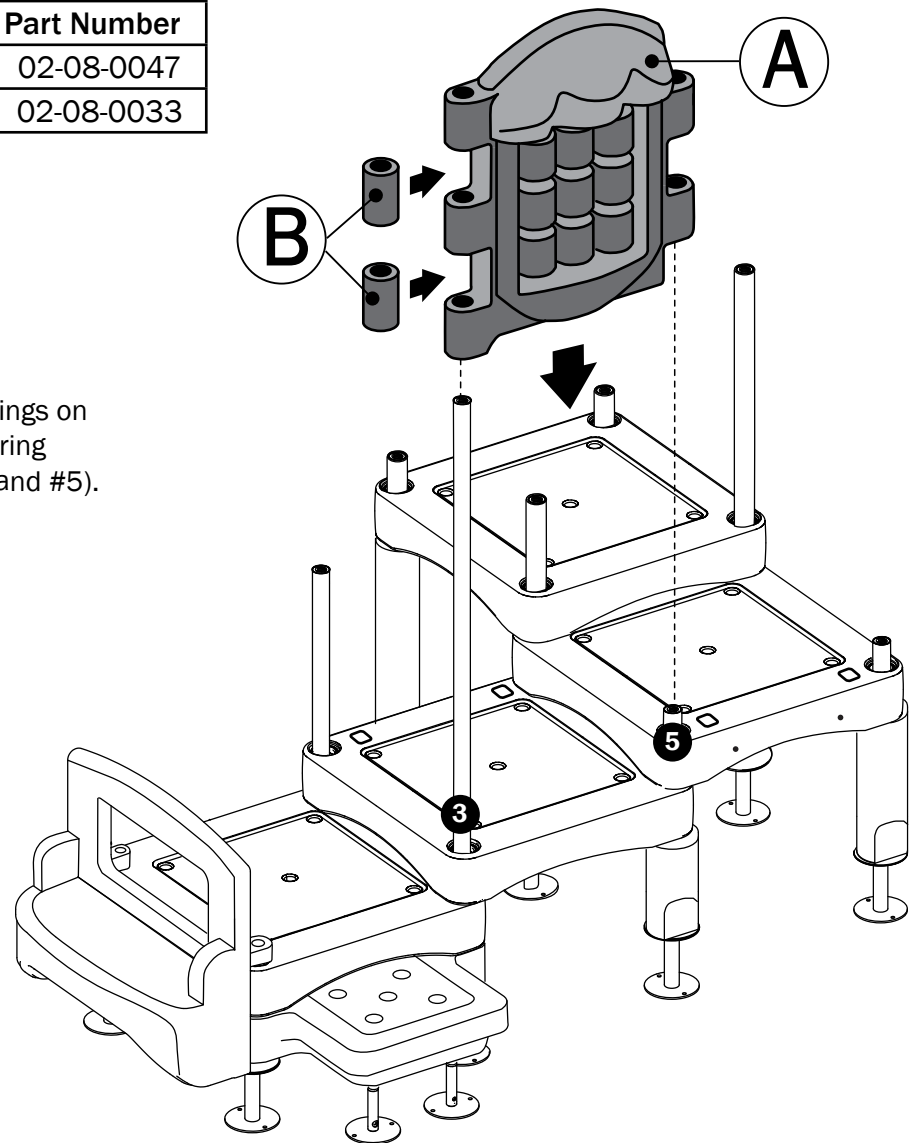

## STEP 9 - INSTALL GEAR PANEL AND HANDHOLD

Parts List			
Letter	Description	Quantity	Part Number
A	Handhold Bracket	1	02-08-0102
B	Climber Handhold - EVEN	1	02-08-0003
C	Gear Panel w/ Inserts	1	02-08-0046

1. Place Handhold Bracket(A) over Lower Posts #8 and #9 to rest on top of deck.
2. Align holes in wings of Climber Handhold(B) with holes in wings of Gear Panel(B) and lower onto Lower Post #8 at the same time.
3. Align hole in bottom of Climber Handhold(B) with stud of Handhold Bracket(A) and lower into position.
4. Insert wing of Gear Panel(C) onto Lower Post #7.

**NOTE: All posts are numbered. Connect upper posts to lower posts with same number.**

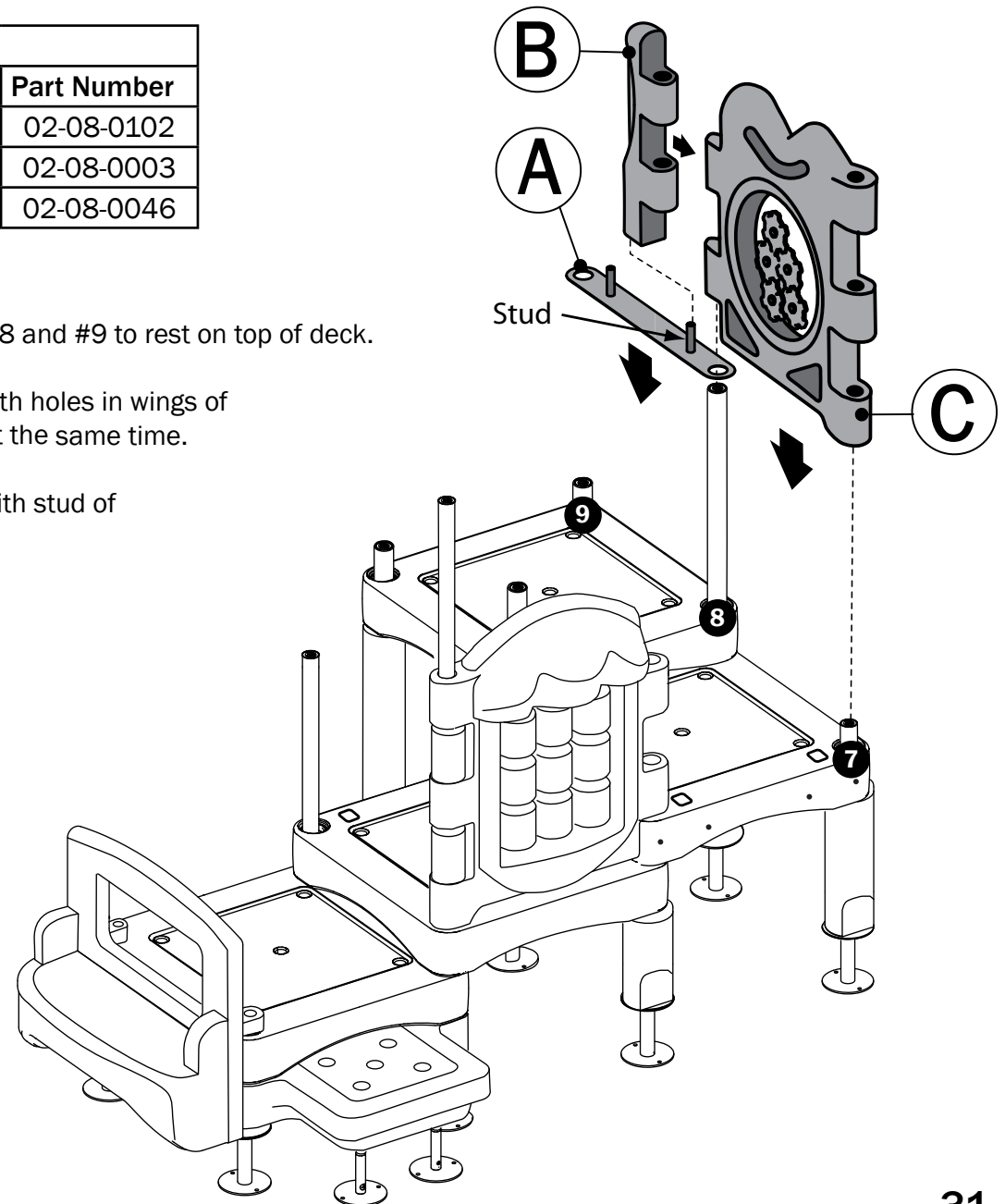

# STEP 10 - INSTALL SLIDE HOOD

Parts List			
Letter	Description	Quantity	Part Number
A	Slide Hood B	1	02-08-0053
B	Upper Post - 34.6" Long	2	02-08-0115

1. Place Slide Hood(A) into position between Lower Posts #5 and #7 and between wings of TouchMath Panel and Gear Panel.

**⚠ The (2) Slide Hoods are NOT identical. Make sure threaded insert in Slide Hood(A) aligns with threaded insert on inner left side of TouchMath Panel.**

**The threaded inserts are used for attaching Panel Connectors in STEP 26 on page 48.**

2. Insert Upper Post #5(B) downward through Slide Hood(A) and TouchMath Panel and secure Upper Post #5(B) to Lower Post #5 using "T" tool provided.

**NOTE: All posts are numbered. Connect upper posts to lower posts with same number.**

3. Insert Upper Post #7(B) downward through Gear Panel and Slide Hood(A) and secure Upper Post #7(B) to Lower Post #7 using "T" tool provided.

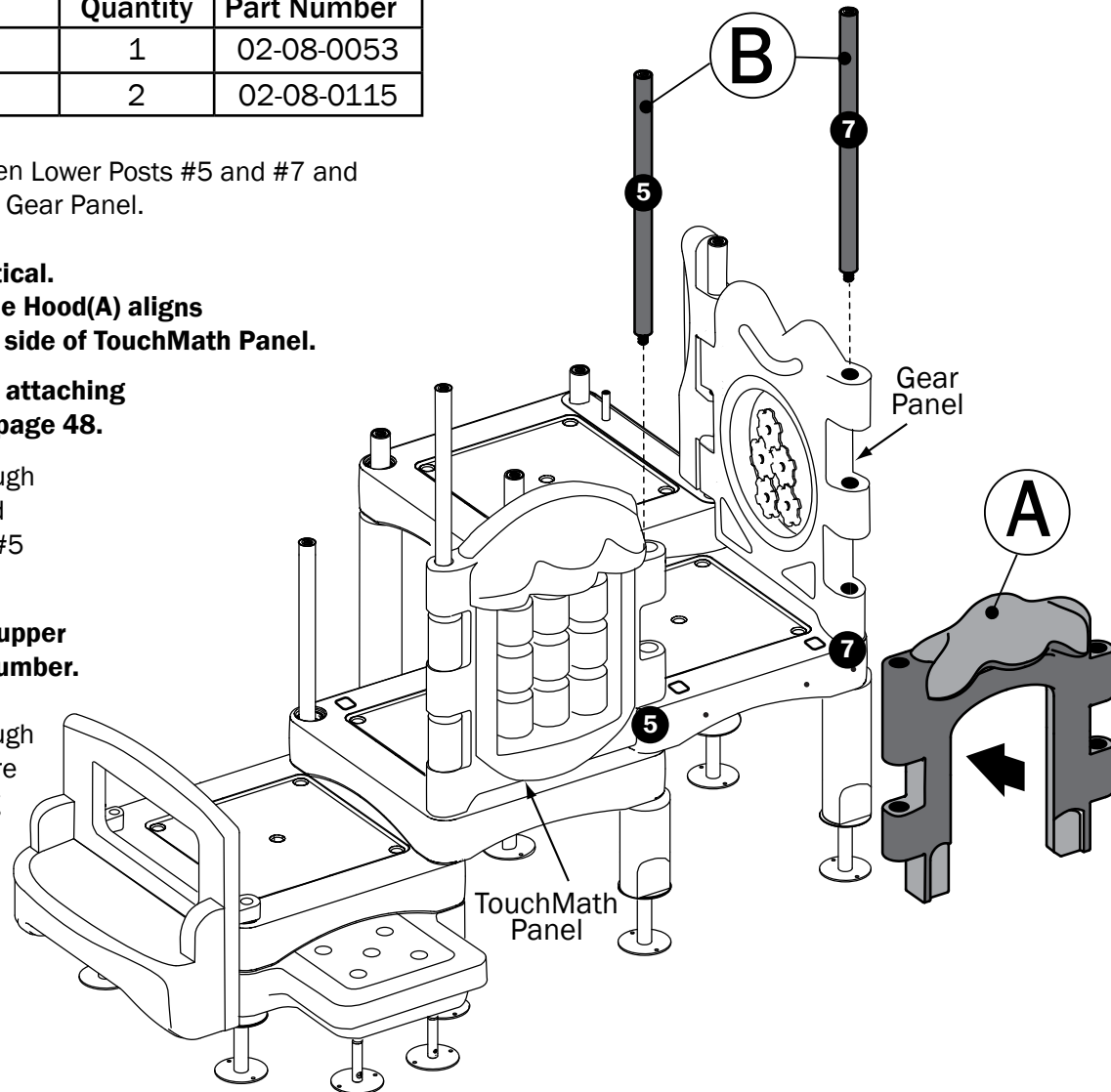

## STEP 11 - INSTALL ARCHED BARRIER PANEL

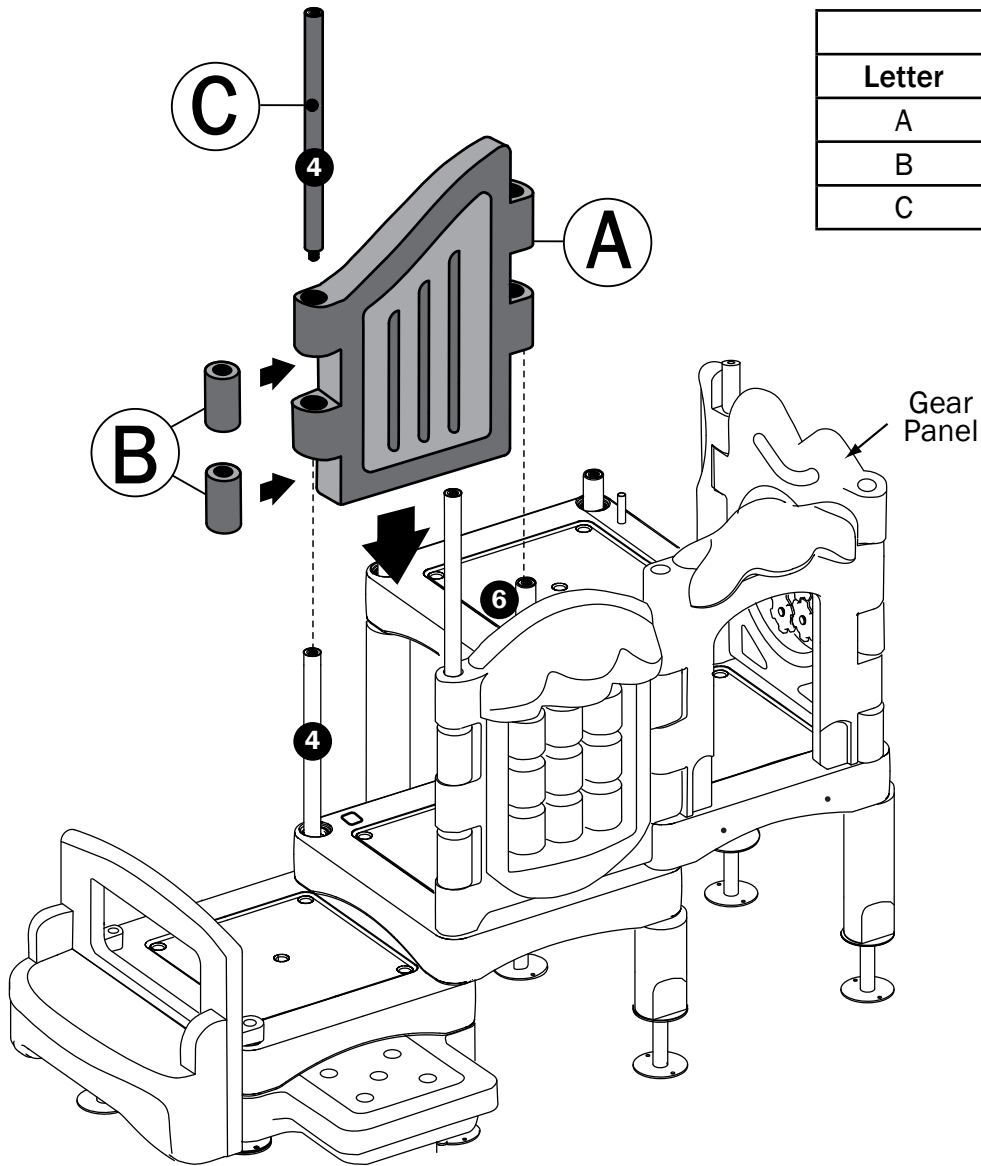

Parts List			
Letter	Description	Quantity	Part Number
A	Arched Barrier Panel	1	02-08-0018
B	Upper Post Cover - 7.38" Long	2	02-08-0033
C	Upper Post - 32.68"	1	02-08-0136

1. Slide (1) Upper Post Cover(B) downward onto Lower Post #4.
2. While holding the remaining Upper Post Cover(B) between wings of the Arched Barrier Panel(A), Lower Arched Barrier Panel(A) onto Lower Posts #4 and #6.
3. Insert Upper Post #4(C) downward through Arched Barrier Panel(A) and Upper Post Covers(B) and into Lower Post #4.
4. Tighten Upper Post #4 to Lower Post #5 clockwise using "T" tool provided.

**NOTE: All posts are numbered.  
Connect upper posts to  
lower posts with same number.**



## STEP 12 - INSTALL CLOCK PANEL

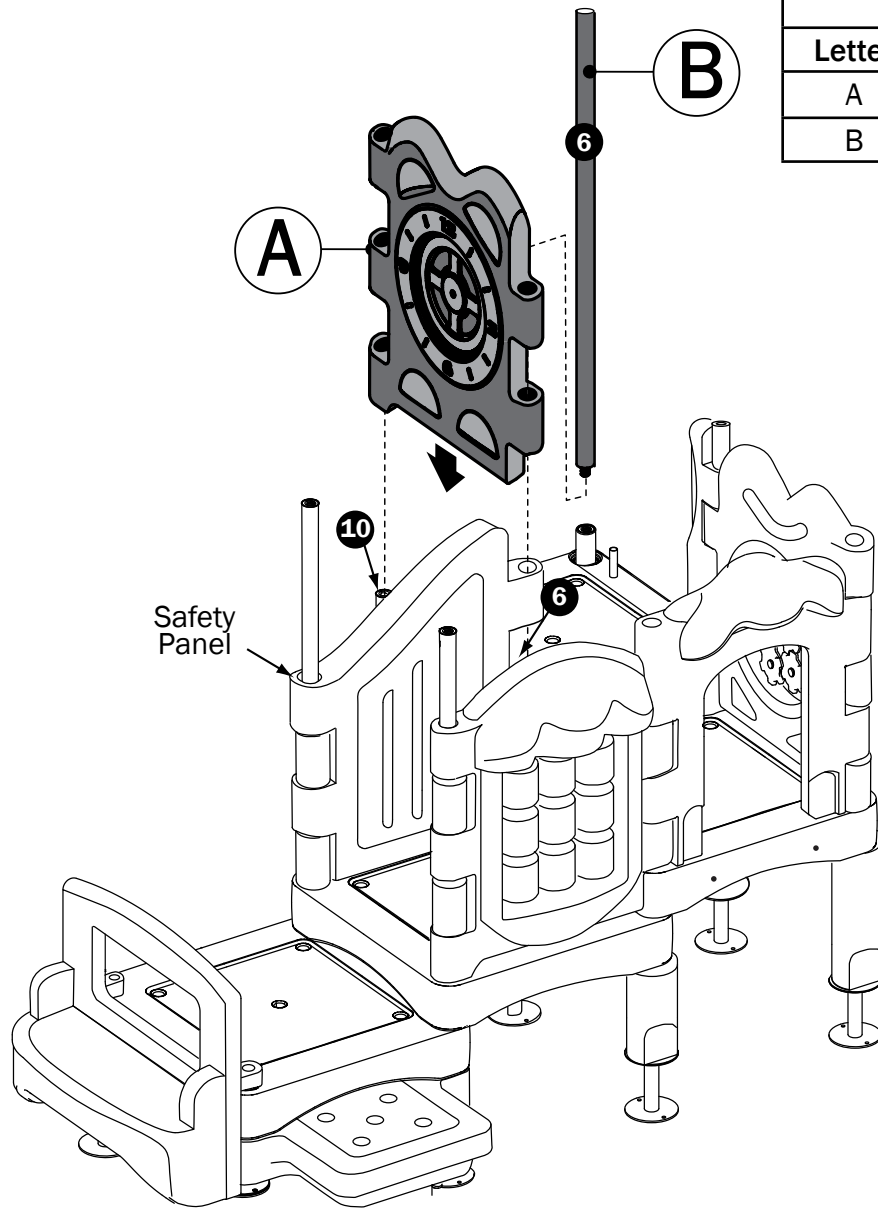

Parts List			
Letter	Description	Quantity	Part Number
A	Clock Panel	1	02-08-0048
B	Upper Post - 57.48" Long	1	02-08-0117

1. Place Clock Panel(A) onto Lower Post #10 and between wings of Safety Panel.
2. Insert Upper Post #6(B) downward through Clock Panel(A) and Safety Panel and into Lower Post #6.
3. Hand tighten clockwise to secure Upper Post #6(B) to Lower Post #6.

**NOTE: All posts are numbered.  
Connect upper posts to  
lower posts with same number.**

## STEP 13 - INSTALL RIGHT HANDHOLD AND SLIDE HOOD

Parts List			
Letter	Description	Quantity	Part Number
A	Climber Handhold-ODD w/ Inserts	1	02-08-0045
B	Slide Hood A	1	02-08-0002
C	Upper Post - 57.48" Long	2	02-08-0117
D	Upper Post - 23.23" Long	1	02-08-0137

1. Place right Climber Handhold-ODD(A) onto Lower Post #9 and right stud of Handhold Bracket.
2. Place wings of Slide Hood(B) between wings of Clock Panel and Right Climber Handhold(A).
3. Insert Upper Post #9(C) downward through Slide Hood(B) and Right Climber Handhold(A).
4. Hand tighten clockwise to secure Upper Post #9(C) to Lower Post #9.
5. Insert Upper Post #10(C) downward through Clock Panel and Slide Hood(B).
6. Hand tighten clockwise to secure Upper Post #10(C) to Lower Post #10.
7. Hand tighten clockwise to secure Upper Post #8(D) to Lower Post #8.

**NOTE: All posts are numbered.  
Connect upper posts to  
lower posts with same number.**

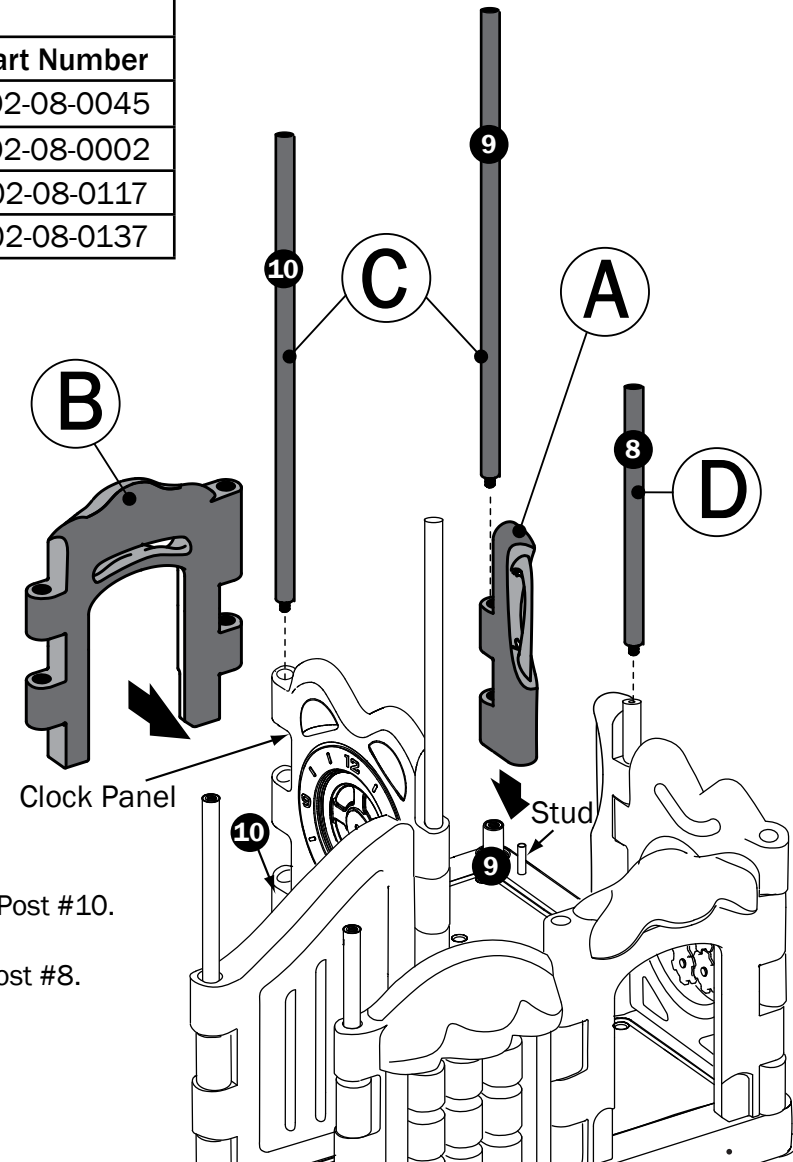

# STEP 14 - ATTACH SLIDE FOOTER PLATE TO SHORT STRAIGHT SLIDE

Parts List			
Letter	Description	Quantity	Part Number
A	Short Straight Slide	1	02-08-0040
B	Slide Mounting Bracket	1	02-08-0120
C	Extension Post - 8" Long	1	02-08-0118
D	Footer Plate	1	02-08-0122
	<b>Hardware Complete</b>	1	33-12-1004
E	M10 x 20mm(3/4") BHCS Bolt	2	33-11-0002
F	M10 Lock Washer	2	33-11-0201
G	M10 Flat Washer	2	33-11-0200
H	M10 x 35mm(1-3/8") BHCS Bolt	2	33-11-0005
I	M10 Lock Nut	2	33-11-0400

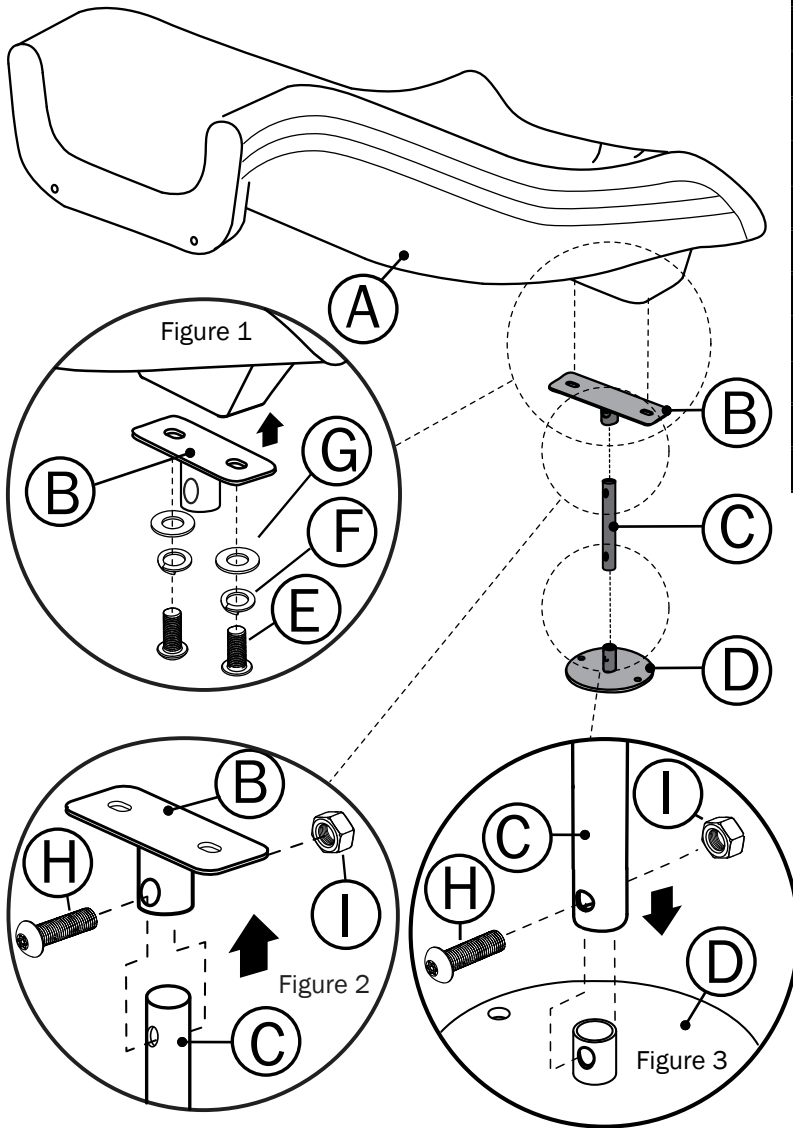

1. Insert Bolts(E), Lock Washers(F) and Flat Washers(G) into slot in Slide Mounting Bracket(B) and into threaded insert in the underside of Slide(A). See Figure 1.
2. Insert Extension Tube(C) into Slide Mounting Bracket(B). Insert Bolt(H) through larger hole in Mounting Bracket(B), through Extension Tube(C) and secure with Lock Nut(I). See Figure 2.
3. Place Extension Tube(C) onto Footer Plate(D) and align holes. Insert Bolt(H) into larger hole of Extension Tube(C), through holes in Footer Plate(D) and secure with Lock Nut(I). See Figure 3.

**⚠ Eliminate Extension Tube(C) if using 2-1/2" poured-in-place or rubber tile applications and bolt Slide Mounting Bracket(B) directly to Footer Plate(D).**

**⚠ If installation requires concrete footers, attach In-ground Footers to Footer Plate(D). at this time. See In-ground Footer Page.**

## STEP 15 - ATTACH SHORT STRAIGHT SLIDE TO DECK #3

Parts List			
Letter	Description	Quantity	Part Number
	<b>Hardware Complete</b>	1	33-12-1004
A	M10 x 75mm(3") BHCS Bolt	2	33-11-0012
B	M10 Lock Washer	2	33-11-0201
C	M10 Flat Washer	2	33-11-0200

1. Insert Bolt(A), Lock Washer(B) and Flat Washer(C) into hole in underside of Slide and into threaded insert in Deck. Lightly tighten. See *Figure 1*.
2. Repeat for other side.
3. Tighten all Bolts(A).

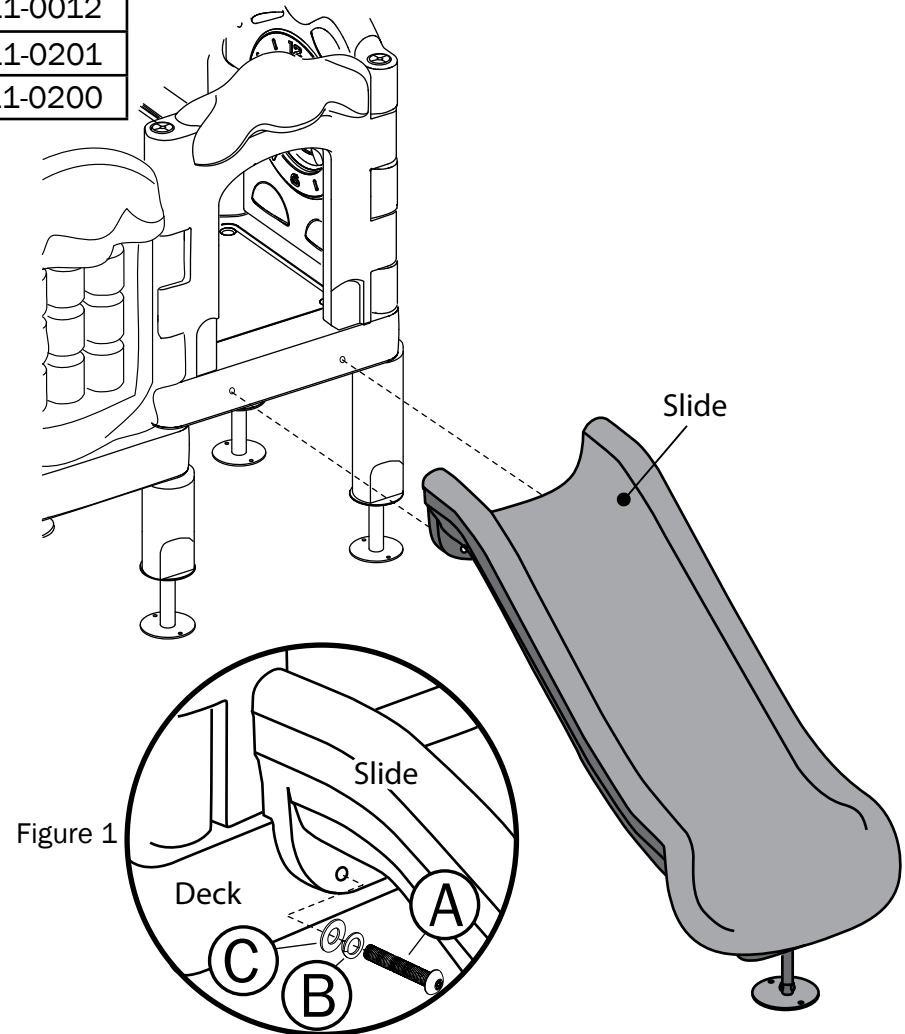

## STEP 16 - ATTACH VINE CLIMBER BRACKET TO DECK #4

Parts List			
Letter	Description	Quantity	Part Number
A	Vine Climber Bracket	1	02-08-0106
	<b>Hardware Complete</b>	1	33-12-1003
B	M10 x 25mm(1") BHCS Bolt	5	33-11-0003
C	M10 Lock Washer	5	33-11-0201
D	M10 Flat Washer	5	33-11-0200

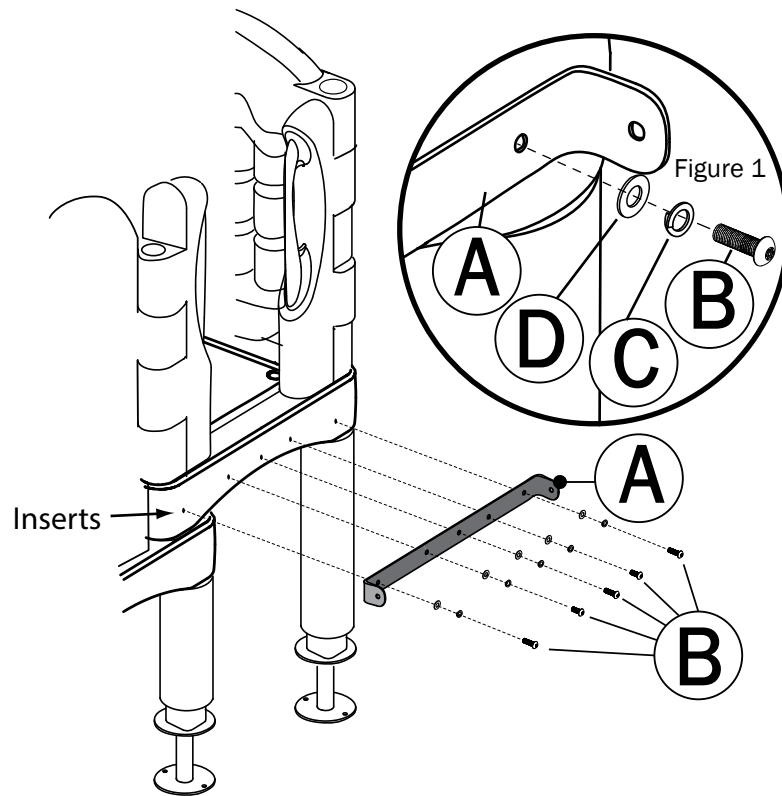

1. Align holes in Vine Climber Bracket(A) with inserts in Deck.
2. Insert Bolts(B), Lock Washers(C) and Flat Washers(D) through Vine Climber Bracket(A) and into inserts in Deck.  
*See Figure 1.*

**NOTE: Lightly tighten Bolts(B) until all Bolts(B) are inserted.**

3. Tighten all Bolts(B).

# STEP 17 - ATTACH FOOTERS TO VINE CLIMBER

Parts List			
Letter	Description	Quantity	Part Number
A	Vine Climber	1	02-08-0024
B	Small Climber Extension Post (2")	2	02-08-0107
B	Large Climber Extension Post (8")	2	02-08-0108
C	Footer Plate	2	02-08-0122
	<b>Hardware Complete</b>	1	33-12-1003
D	M10 x 35mm(1-3/8") BHCS Bolt	2	33-11-0005
E	M10 Lock Nut	2	33-11-0400
F	M10 x 25(1") BHCS Bolt	2	33-11-0003
G	M10 Lock Washer	2	33-11-0201
H	M10 Flat Washer	2	33-11-0200

**NOTE: There are (2) sizes of Vine Climber Extension Posts(B) provided.**  
**Use the 2" Small Climber Extension Post ONLY for 2-1/2" poured-in-place surfacing or rubber tiles.**  
**Use the 8" Large Climber Extension Post for Engineered Wood Fiber.**

1. Insert Extension Post(B) onto Footer Plate(C).
2. Insert Bolt(D) through larger hole in Extension Post(B), through hole in Footer Plate(C) and secure with Lock Nut(E). Repeat Steps 1 and 2 for other Extension Post(B). See *Figure 1*.
3. Insert Bolt(F), Lock Washer(G) and Flat Washer(H) into hole in Extension Post(B) and into threaded insert in Vine Climber(A). See *Figure 2*.
4. Repeat for other Extension Post(B).

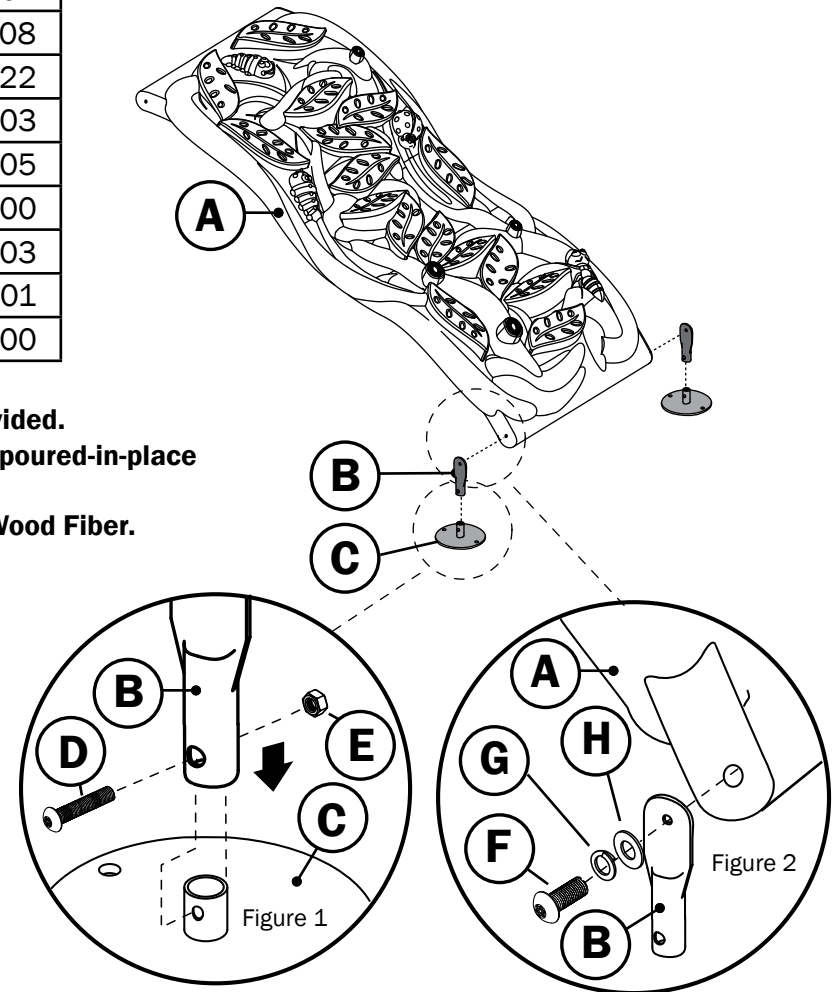

## STEP 18 - ATTACH VINE CLIMBER TO DECK MOUNTING BRACKET

Parts List			
Letter	Description	Quantity	Part Number
	Hardware Complete	1	33-12-1003
A	M10 x 25mm(1") BHCS Bolt	2	33-11-0003
B	M10 Lock Washer	2	33-11-0201
C	M10 Flat Washer	2	33-11-0200

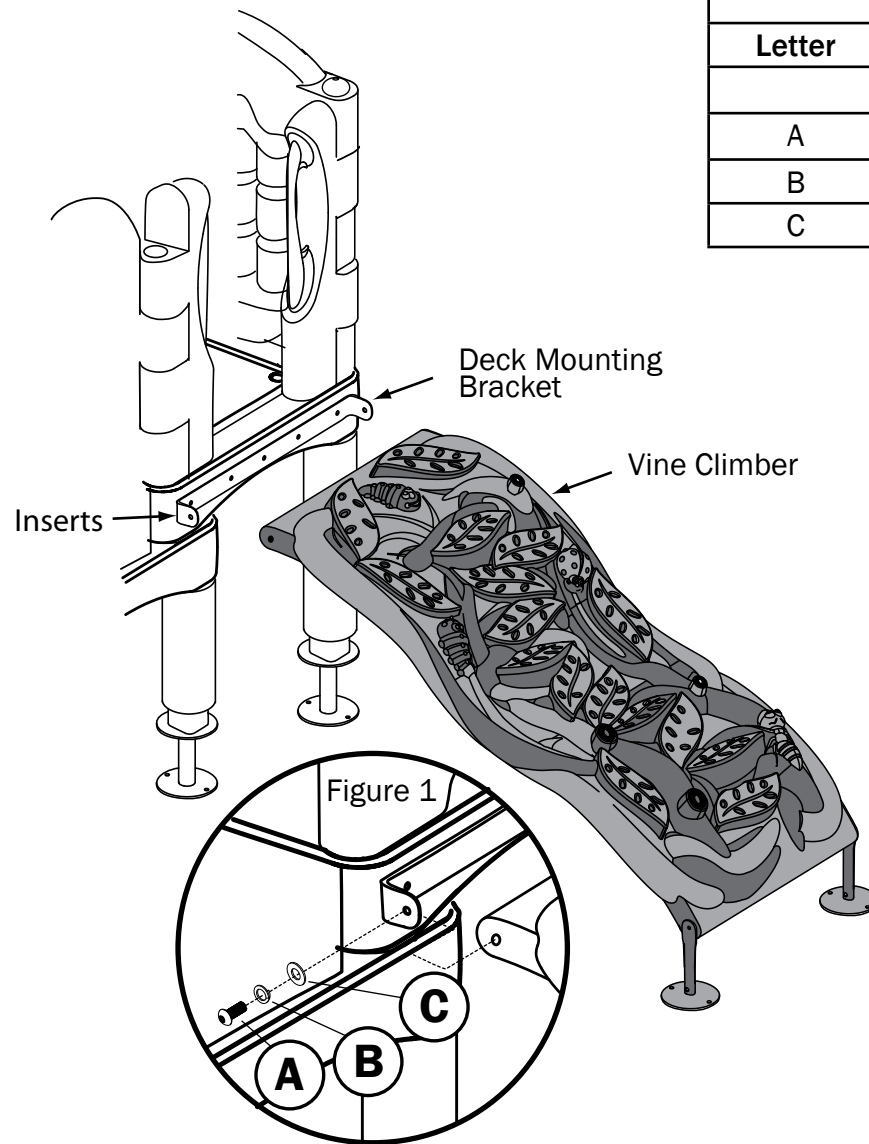

1. Insert Bolt(A), Lock Washer(B) and Flat Washer(C) into hole in Deck Mounting Bracket and into threaded insert in Vine Climber.  
See *Figure 1*.
2. Repeat for other side.
3. Tighten all Bolts(A).

# STEP 19 - ATTACH SLIDE FOOTER PLATE TO LONG STRAIGHT SLIDE

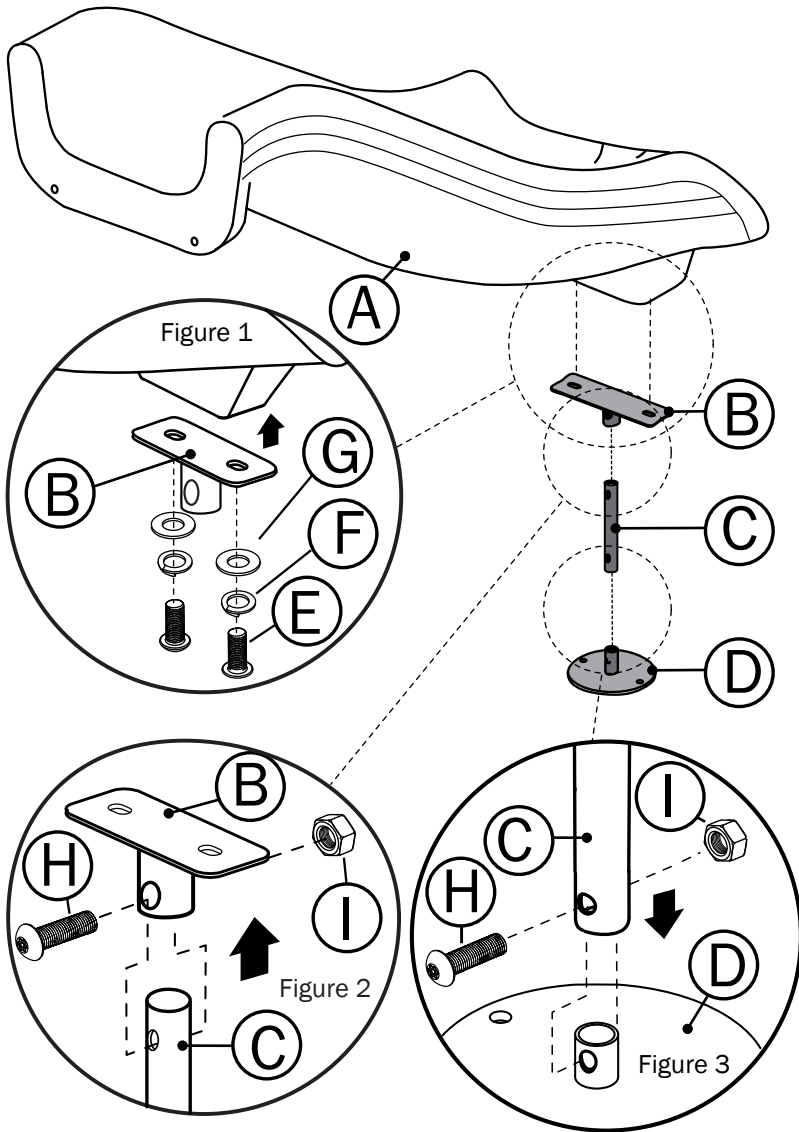

Parts List			
Letter	Description	Quantity	Part Number
A	Long Straight Slide	1	02-08-0019
B	Slide Mounting Bracket	1	02-08-0120
C	Extension Post - 8" Long	1	02-08-0118
D	Footer Plate	1	02-08-0122
	<b>Hardware Complete</b>	1	33-12-1004
E	M10 x 20mm(3/4") BHCS Bolt	2	33-11-0002
F	M10 Lock Washer	2	33-11-0201
G	M10 Flat Washer	2	33-11-0200
H	M10 x 35mm(1-3/8") BHCS Bolt	2	33-11-0005
I	M10 Lock Nut	2	33-11-0400

1. Insert Bolts(E), Lock Washers(F) and Flat Washers(G) into slot in Slide Mounting Bracket(B) and into threaded insert in the underside of Slide(A). See *Figure 1*.
2. Insert Extension Tube(C) into Slide Mounting Bracket(B). Insert Bolt(H) through larger hole in Mounting Bracket(B), through Extension Tube(C) and secure with Lock Nut(I). See *Figure 2*.
3. Place Extension Tube(C) onto Footer Plate(D) and align holes. Insert Bolt(H) into larger hole of Extension Tube(C), through holes in Footer Plate(D) and secure with Lock Nut(I). See *Figure 3*.

**!** Eliminate Extension Tube(C) if using 2-1/2" poured-in-place or rubber tile applications and bolt Slide Mounting Bracket(B) directly to Footer Plate(D).

**!** If installation requires concrete footers, attach In-ground Footers to Footer Plate(D), at this time. See *In-ground Footer Page*.



## STEP 20 - ATTACH LONG STRAIGHT SLIDE TO DECK #4

Parts List			
Letter	Description	Quantity	Part Number
	<b>Hardware Complete</b>	1	33-12-1004
A	M10 x 75mm(3") BHCS Bolt	2	33-11-0012
B	M10 Lock Washer	2	33-11-0201
C	M10 Flat Washer	2	33-11-0200

1. Insert Bolt(A), Lock Washer(B) and Flat Washer(C) into hole in underside of Slide and into threaded insert in Deck. Lightly tighten. See *Figure 1*.
2. Repeat for other side.
3. Tighten all Bolts(A).

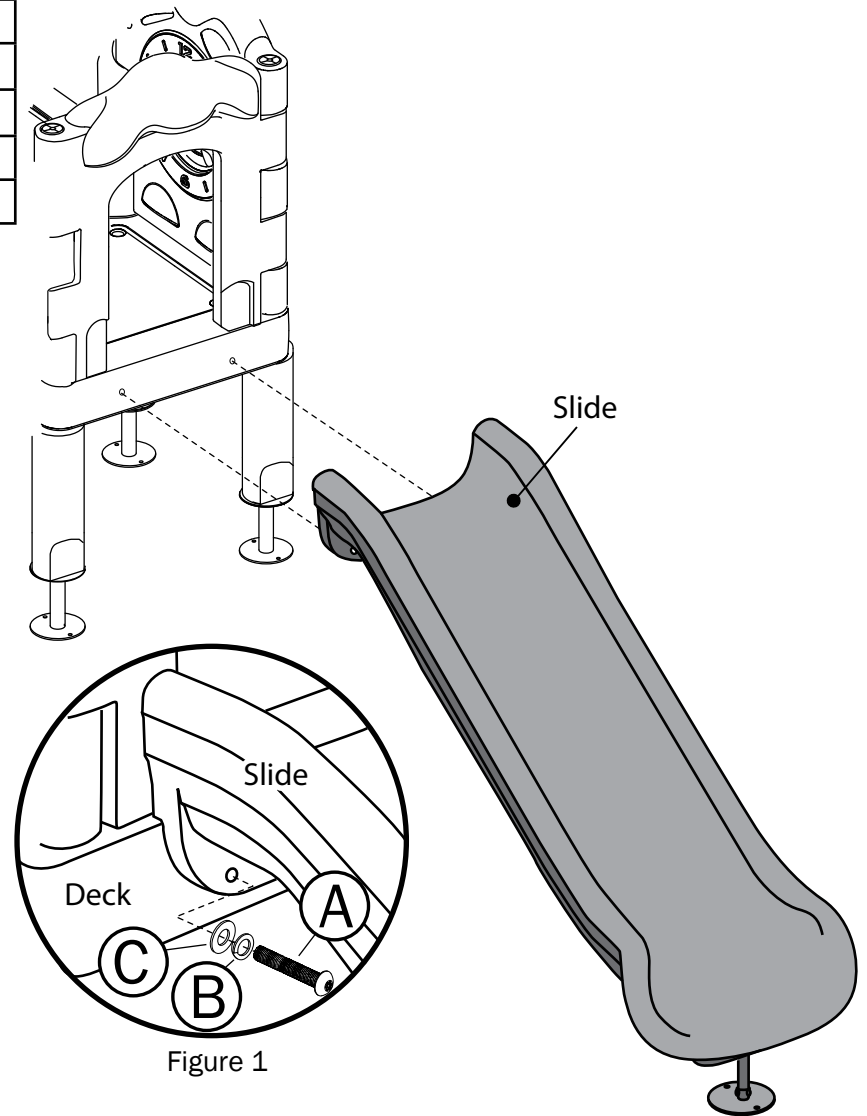

# STEP 21 - ATTACH BONGOS SUPPORT BRACKET TO BONGOS

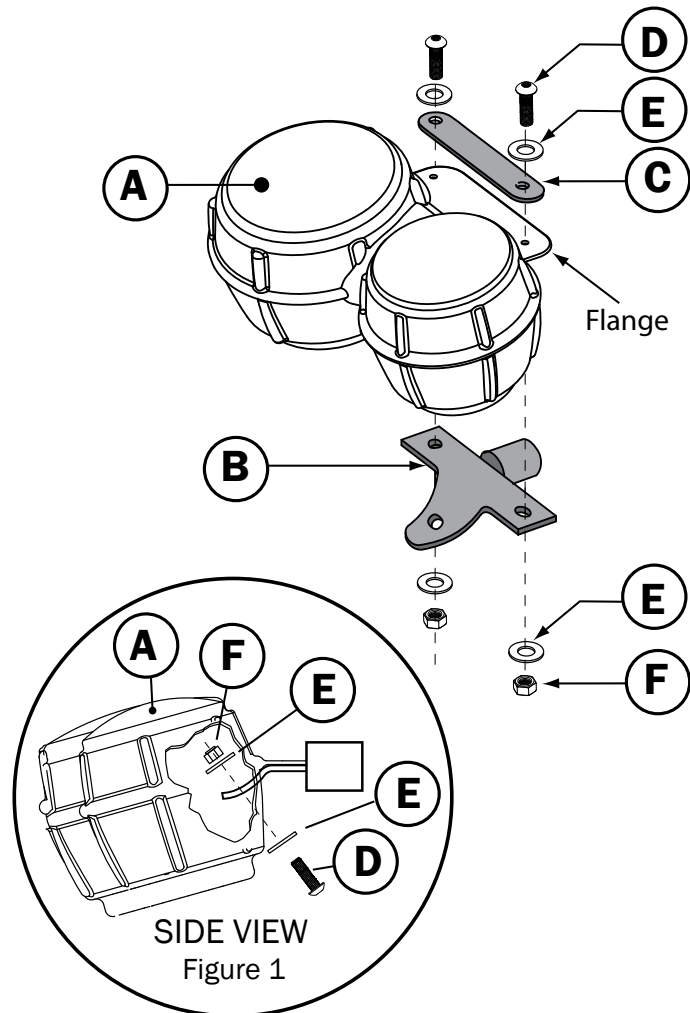

Parts List			
Letter	Description	Quantity	Part Number
A	Bongos	1	02-08-0025
B	Bongos Support Bracket	1	02-08-0103
C	Mounting Bar	1	02-08-0126
	<b>Hardware Complete</b>	1	33-12-1005
D	M8 x 25mm(1") BHCS Bolt	3	33-11-0102
E	M8 Flat Washer	6	33-11-0300
F	M8 Lock Nut	3	33-11-0500

1. Insert (2) Bolts(D) and (2) Flat Washers(E) into holes in Mounting Bar(C), through holes in flange of Bongos(A), through holes in Bongos Support Bracket(B) and secure with (2) Flat Washers(E) and (2) Lock Nuts(F).
2. From underside of Bongos(A), insert Bolt(D), Flat Washer(E) through Bongos Support Bracket(B), into hole in Bongos(A) and secure from inside of Bongos(A) with Flat Washer(E) and Lock Nut(F). See Figure 1.

## STEP 22 - ATTACH BONGOS MOUNTING BRACKET TO DECK #3

Parts List			
Letter	Description	Quantity	Part Number
A	Bongos Mounting Bracket	1	02-08-0104
	<b>Hardware Complete</b>	1	33-12-1005
B	M10 x 25mm(1") BHCS Bolt	4	33-11-0003
C	M10 Lock Washer	4	33-11-0201
D	M10 Flat Washer	4	33-11-0200

1. Lift LEFT side of Gear Panel.
2. Slide Bongos Mounting Bracket(A) under Gear Panel.
3. Align Holes in Bongos Mounting Bracket(A) with threaded inserts in Deck.
4. Secure Bongos Mounting Bracket(A) to Deck using (4) Bolts(B), (4) Lock Washers(C) and (4) Flat Washers(D).

 **Insert all Bolts(B) before tightening, then securely tighten.**

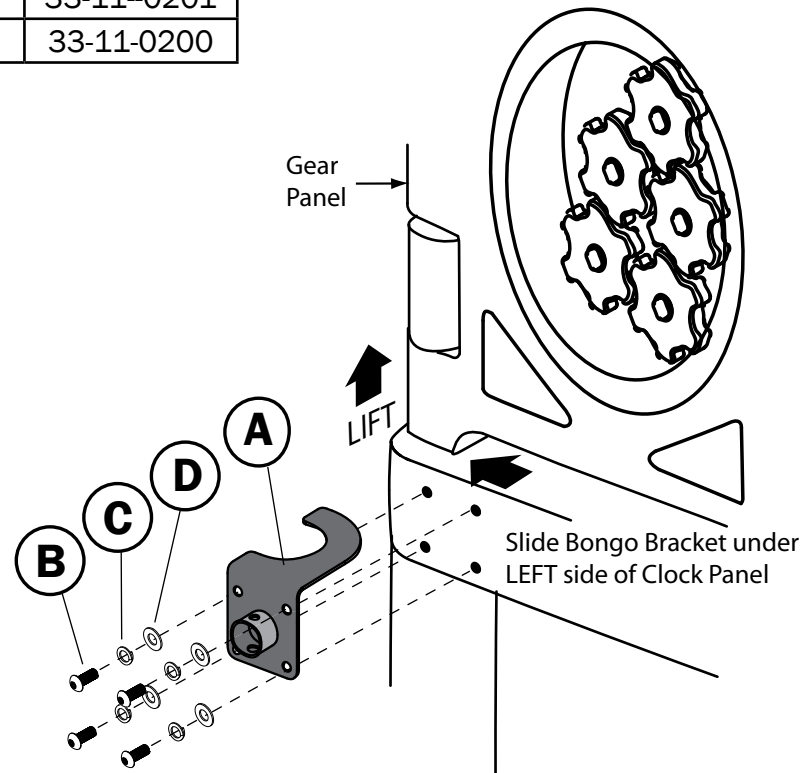

## STEP 23 - ATTACH BONGOS TO MOUNTING BRACKET

Parts List			
Letter	Description	Quantity	Part Number
	<b>Hardware Complete</b>	1	33-12-1005
A	M8 x 25mm(1") BHCS Bolt	1	33-11-0102
B	M8 Barrel Nut	1	33-11-0501

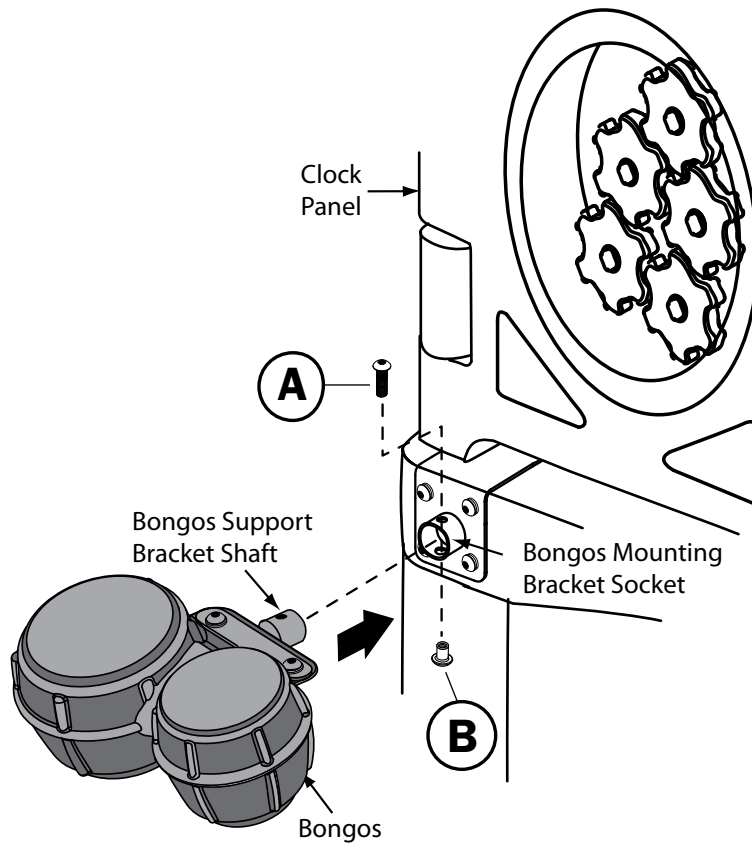

1. Apply Loctite adhesive to threads of Bolt(A).
2. Insert shaft of Bongos Support Bracket into socket of Bongos Mounting Bracket and align holes.
3. Insert Bolt(A) downward through both brackets and secure with Barrel Nut(B).

## STEP 24 - ATTACH RAINWHEEL MOUNTING BRACKET TO DECK #4

Parts List			
Letter	Description	Quantity	Part Number
A	Rainwheel Mounting Bracket	1	02-08-0127
	<b>Hardware Complete</b>	1	33-12-1006
B	M10 x 25mm(1") BHCS Bolt	4	33-11-0003
C	M10 Lock Washer	4	33-11-0201
D	M10 Flat Washer	4	33-11-0200

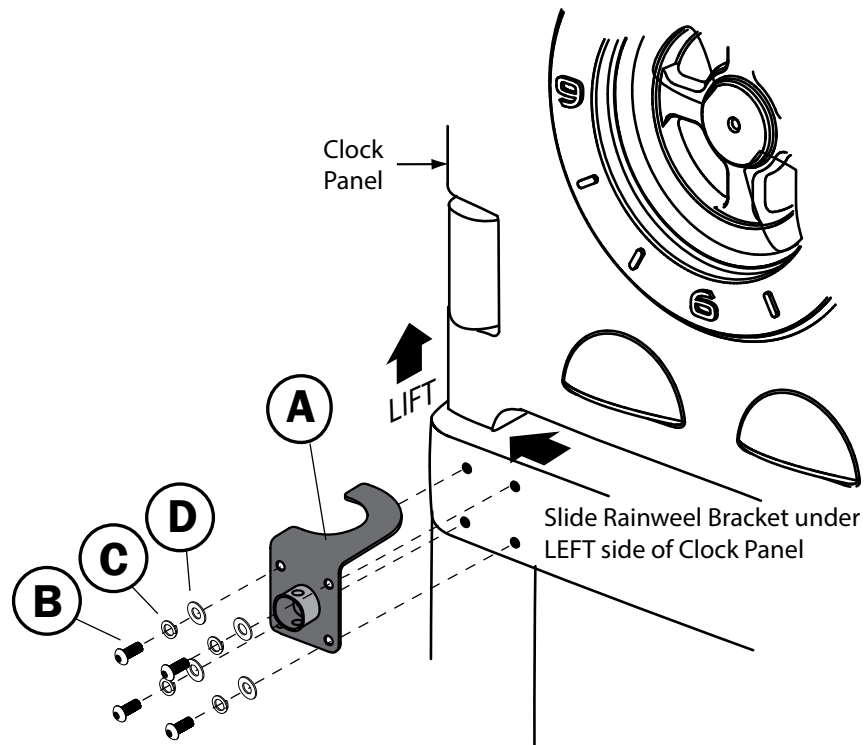

1. Lift LEFT side of Clock Panel.
2. Slide Rainwheel Bracket(A) under Clock Panel.
3. Align Holes in Rainwheel Bracket(A) with threaded inserts in Deck.
4. Secure Rainwheel Bracket(A) to Deck using (4) Bolts(B), (4) Lock Washers(C) and (4) Flat Washers(D).

**⚠ Insert all Bolts(B) before tightening, then securely tighten.**

## STEP 25 - ATTACH RAINWHEEL TO MOUNTING BRACKET

Parts List			
Letter	Description	Quantity	Part Number
A	Rainwheel	1	02-08-0026
	<b>Hardware Complete</b>	1	33-12-1006
B	M8 x 30mm(1-3/16") BHCS Bolt	1	33-11-0104
C	M8 Barrel Nut	1	33-11-0501

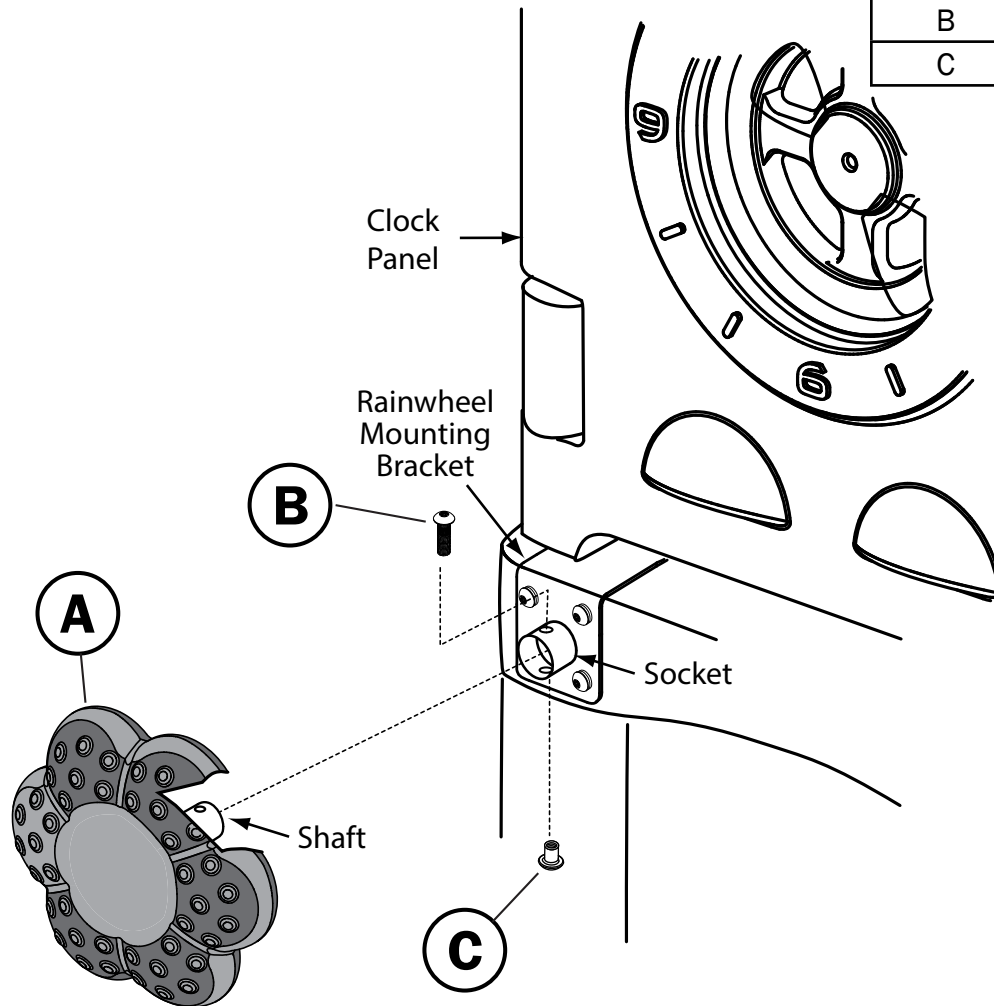

1. Insert shaft of Rainwheel(A) into socket of Rainwheel Mounting Bracket.
2. Insert Bolt(B) downward through both brackets and secure with Barrel Nut(C) and tighten.

# STEP 26 - ATTACH 90 DEGREE AND 180 DEGREE CONNECTORS

Parts List			
Letter	Description	Quantity	Part Number
A	180 Degree Panel Connector	1	02-08-0101
B	90 Degree Panel Connector	3	02-08-0100
	<b>Hardware Complete</b>	1	33-12-1012
C	M10 x 25mm(1") BHCS Bolt	8	33-11-0003

1. Apply Loctite adhesive to Bolts(C).

2. Align Holes in 180 Degree Panel Connector(A) with inserts in TouchMath Panel and Slide Hood on post #5.

3. Secure with (2) Bolts(C).

4. Align Holes in 90 Degree Panel Connector(A) with inserts in Slide Hood and Gear Panel in post #7.

5. Secure with (2) Bolts(C).

6. Align Holes in 90 Degree Panel Connector(A) with inserts in Slide Hood and Right Climber Handhold on post #9.

7. Secure with (2) Bolts(C).

8. Align Holes in 90 Degree Panel Connector(A) with inserts in Slide Hood and Right Climber Handhold on post #10.

9. Secure with (2) Bolts(C).

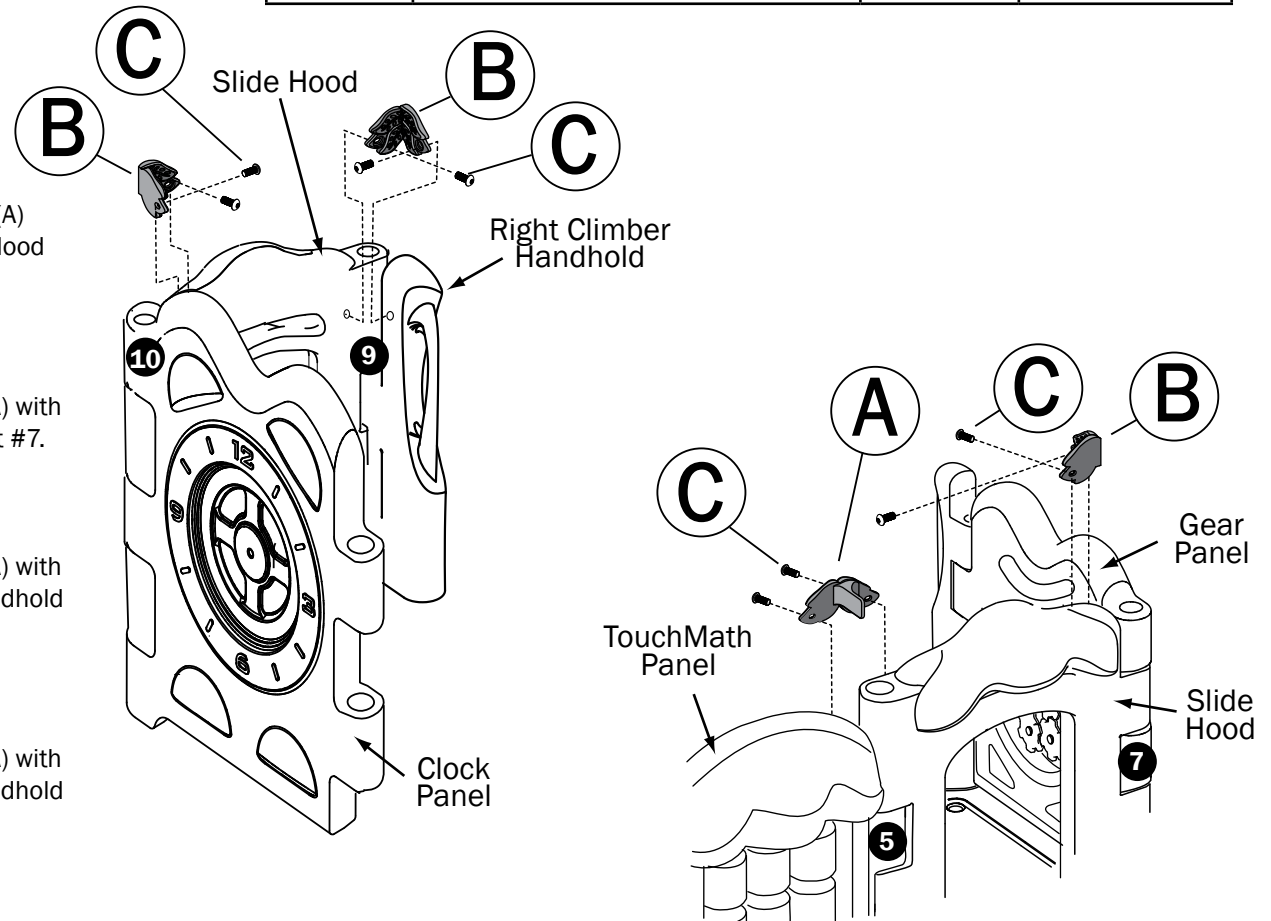

# STEP 27 - ATTACH TELESCOPE TO POST #5

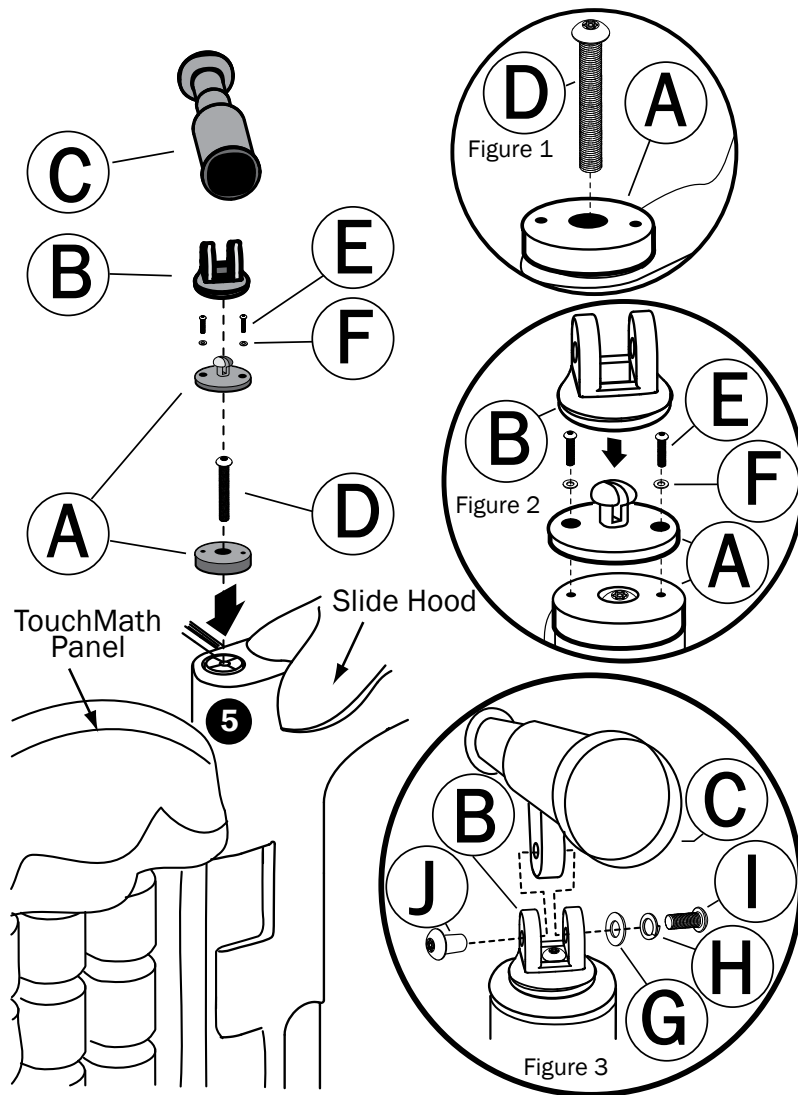

Parts List			
Letter	Description	Quantity	Part Number
A	Mounting Plate (2 parts)	1	02-08-0133
B	Mounting Bracket	1	02-08-0105
C	Telescope	1	02-08-0005
	<b>Hardware Complete</b>	1	33-12-1001
D	M10 x 50mm(2") BHCS Bolt	1	33-11-0010
E	M6 x 20mm(3/4") BHCS Bolt	2	33-11-0707
F	M6 Flat Washer	2	33-11-0708
G	M8 Flat Washer	1	33-11-0300
H	M8 Lock Washer	1	33-11-0301
I	M8 x 30mm(1-3/16") BHCS Bolt	1	33-11-0104
J	M8 Barrel Nut	1	33-11-0501

1. Apply Loctite adhesive to Bolt(D).
2. Place base of Mounting Plate(A) on top of Upper Post #5 and secure with Bolt(D). See *figure 1*.
3. Place top of Mounting Plate(A) onto base of Mounting Plate(A) and secure with (2) Bolts(E) and (2) Flat Washers(F) using allen wrench provided. See *Figure 2*.
4. Push Mounting Bracket(B) downward onto stud of Mounting Plate(A). See *Figure 2*.  
**NOTE: Mounting Bracket(B) spins freely.**
5. To attach Telescope(C) to Telescope Bracket(B), insert Flat Washer(G), Lock Washer(H) and Bolt(I) into one side of Telescope Bracket(B) and Secure with Barrel Nut(J). See *Figure 3*.



## STEP 28 - ATTACH UPPER POST COVERS

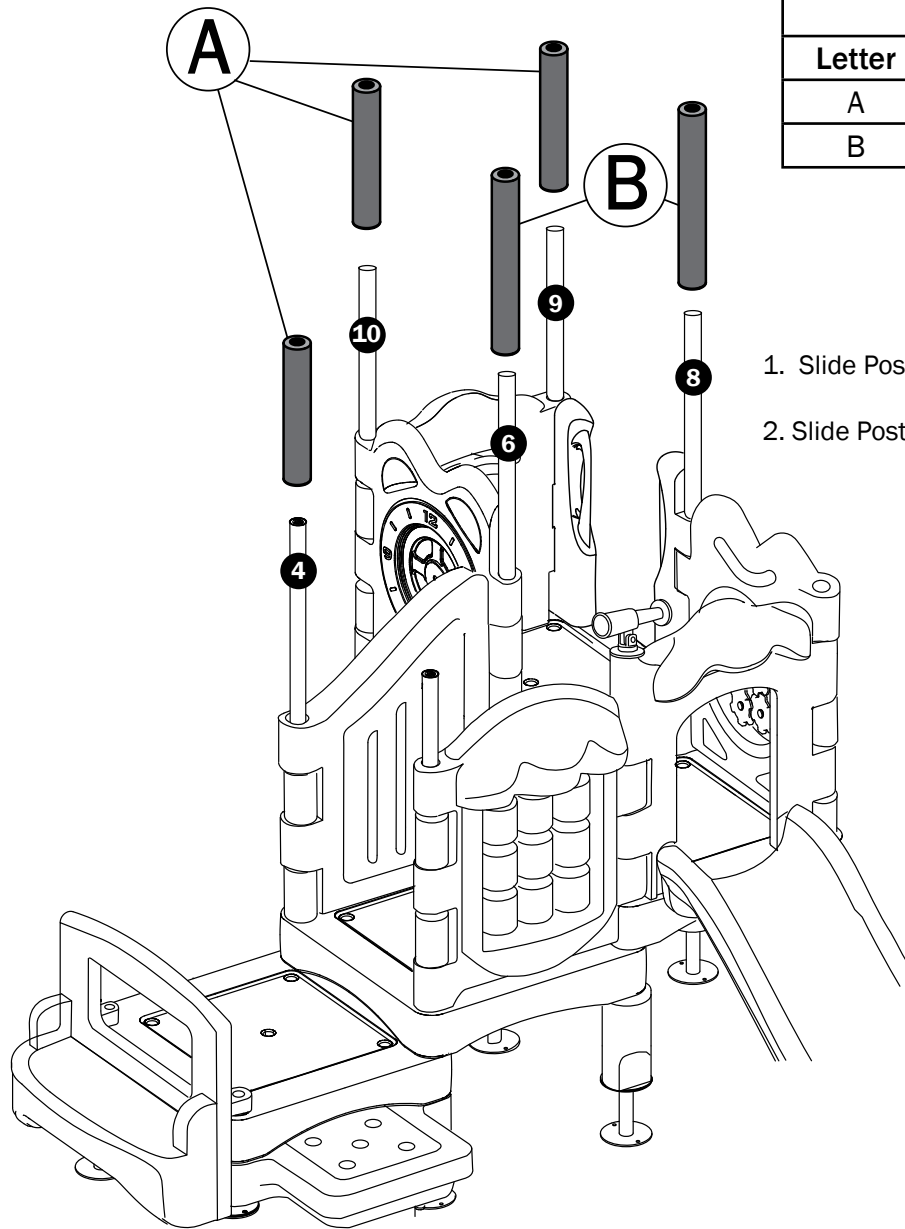

Parts List			
Letter	Description	Quantity	Part Number
A	Upper Post Cover - 21.38" Long	3	02-08-0034
B	Upper Post Cover - 28.88" Long	2	02-08-0035

1. Slide Post Covers(A) downward over Upper Posts #4, #9 and #10.
2. Slide Post Cover(B) downward over Upper Post #6 and #8.

# STEP 29 - ATTACH LEAF ARCHWAY

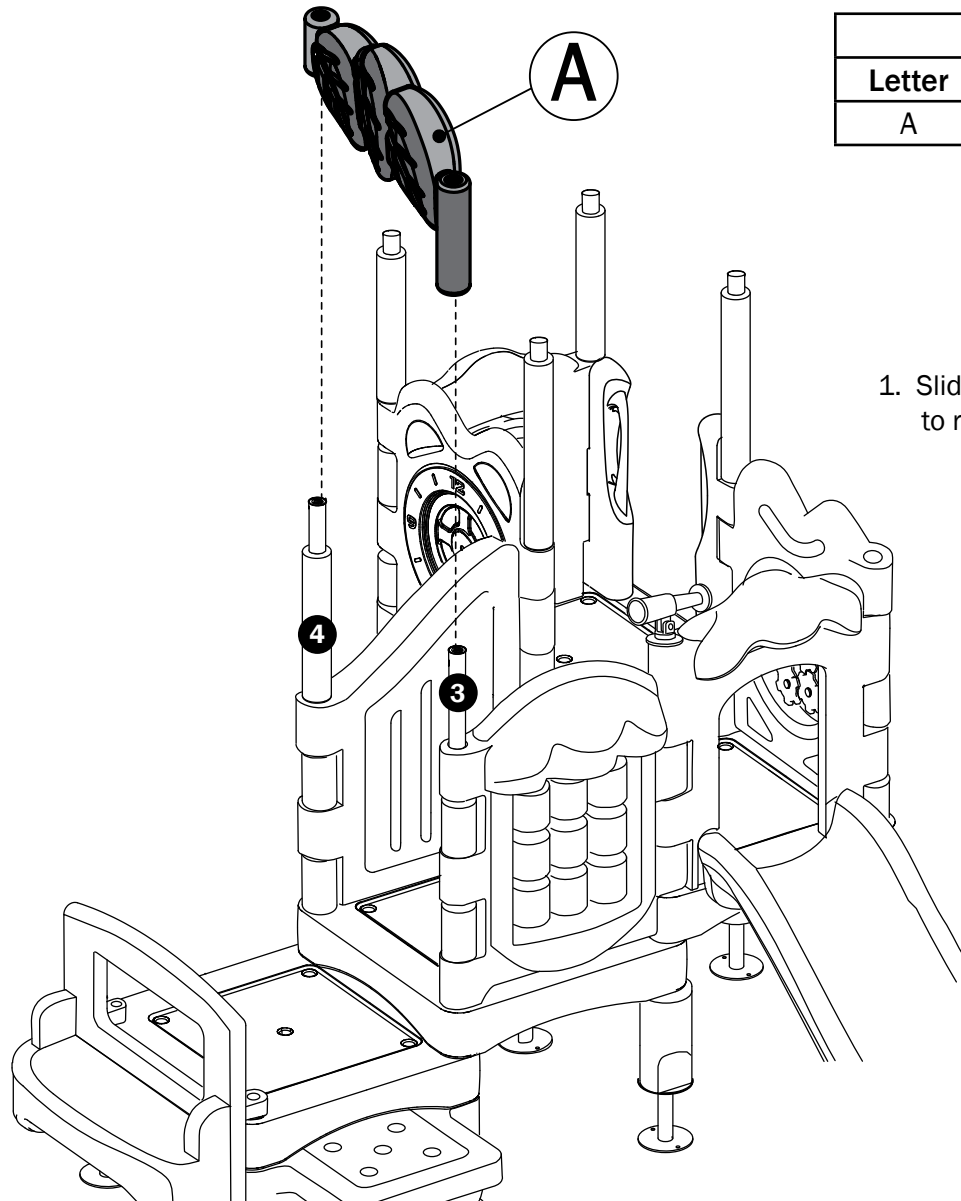

Parts List			
Letter	Description	Quantity	Part Number
A	Entry Archway Leaves	1	02-08-0008

1. Slide Leaf Archway(A) downward over Upper Posts #3 and #4 to rest on TouchMath Panel and Upper Post Cover.

# STEP 30 - ATTACH ROOF

Parts List			
Letter	Description	Quantity	Part Number
A	Roof	1	02-08-0001
	<b>Hardware Complete</b>	1	33-12-1009
B	M5 x76mm (3") Self-tapping Screw	4	33-11-0600

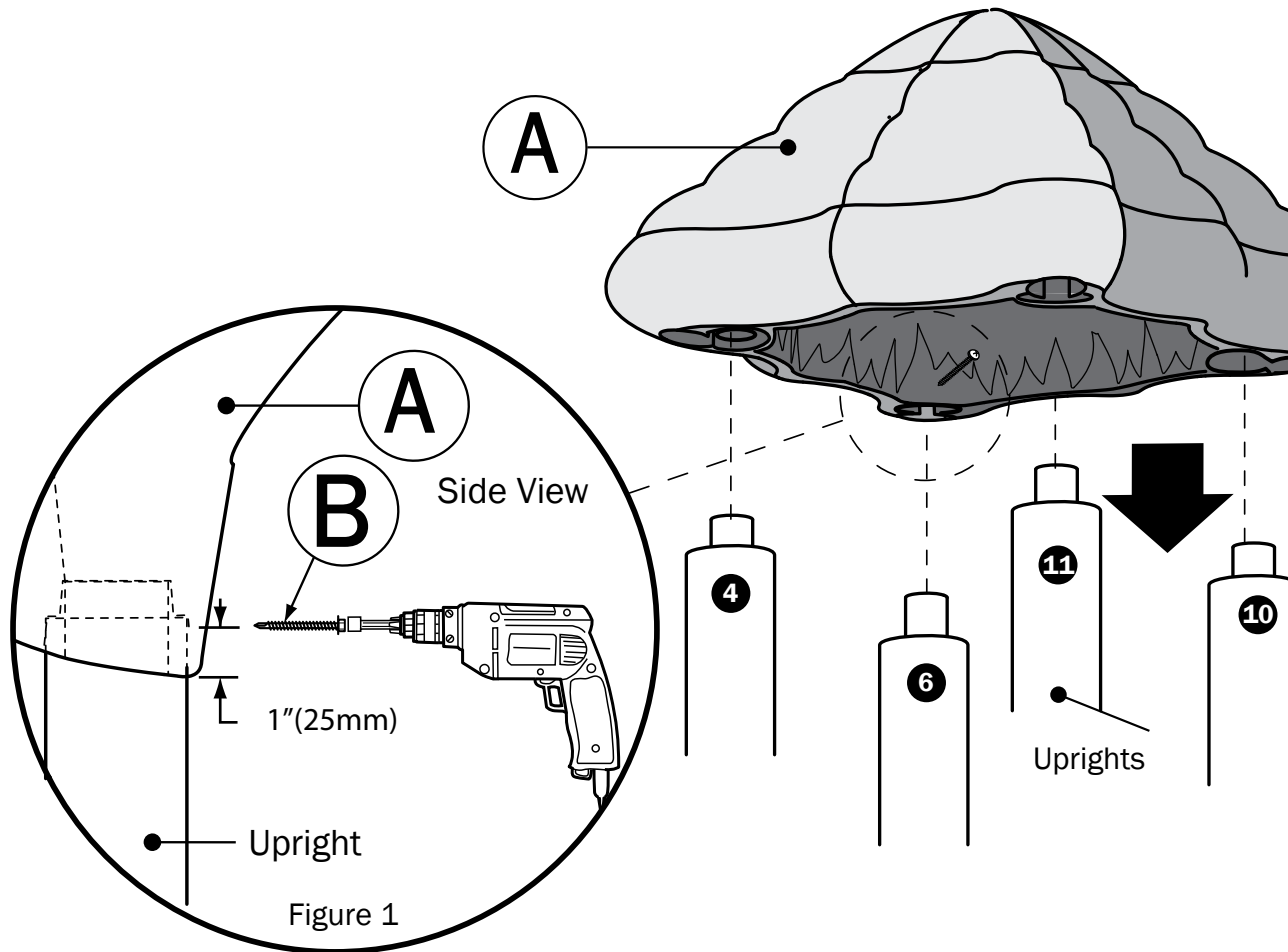

1. Lower Roof(A) onto Uprights.  
**NOTE: Use Inside Sockets**
2. Centered horizontally with Upright, measure 1"(25mm) up from bottom of Roof(A) and drill 1/8" pilot hole through Roof and into Upright. See *Figure 1*.
3. Secure Roof(A) to Uprights with (4) Self-tapping Screws(B). See *Figure 1*.
4. Repeat Steps 2 and 3 for remaining (3) Self-tapping Screws(B).

# STEP 31 - ATTACH POST CAPS

Parts List			
Letter	Description	Quantity	Part Number
A	Post Cap	5	02-08-0027
	<b>Hardware Complete</b>	1	33-12-1024
B	M10 x 50mm(2") BHCS Bolt	5	33-11-0010

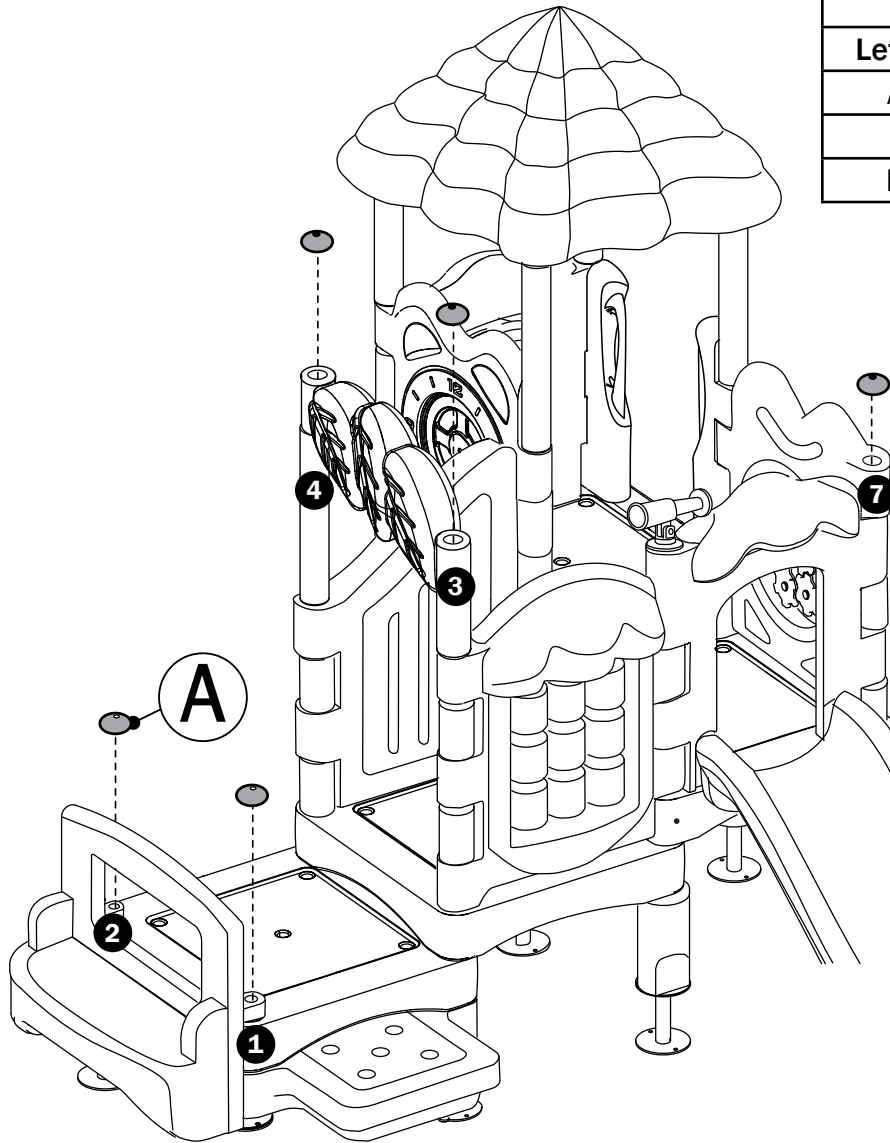

1. Use "T" Tool, turn clockwise to Tighten all Upper Posts to Lower Posts. See *Figure 1*.
2. Apply Loctite to threads of Bolts(B).
3. Place Post Caps(A) on top of Posts #1, #2, #3, #4 and #7. Insert Bolts(B), into treaded inserts on Posts and Tighten.

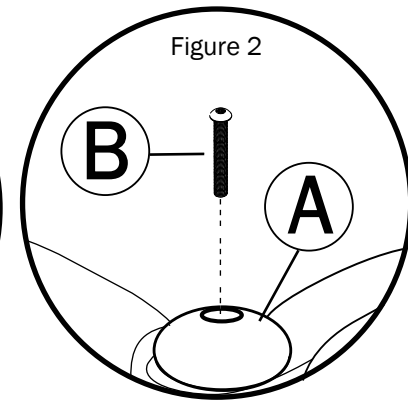
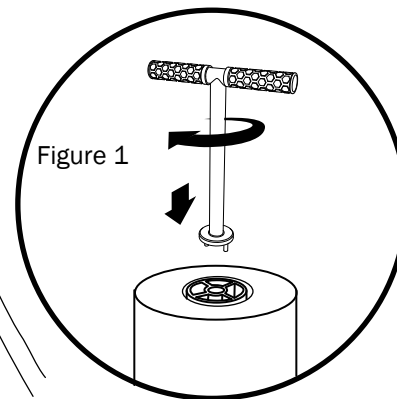

# STEP 32 - ATTACH FOOTER COVERS

Parts List			
Letter	Description	Quantity	Part Number
A	Footer Cover	14	02-08-0009
	<b>Hardware Complete</b>	<b>1</b>	<b>33-12-1015</b>
B	M8 x 40mm(1-9/16") BHCS Bolt	14	33-11-0106
C	M8 Lock Washer	14	33-11-03 01
D	M8 Flat Washer	14	33-11-0300
E	M8 Barrel Nut	14	33-11-0501

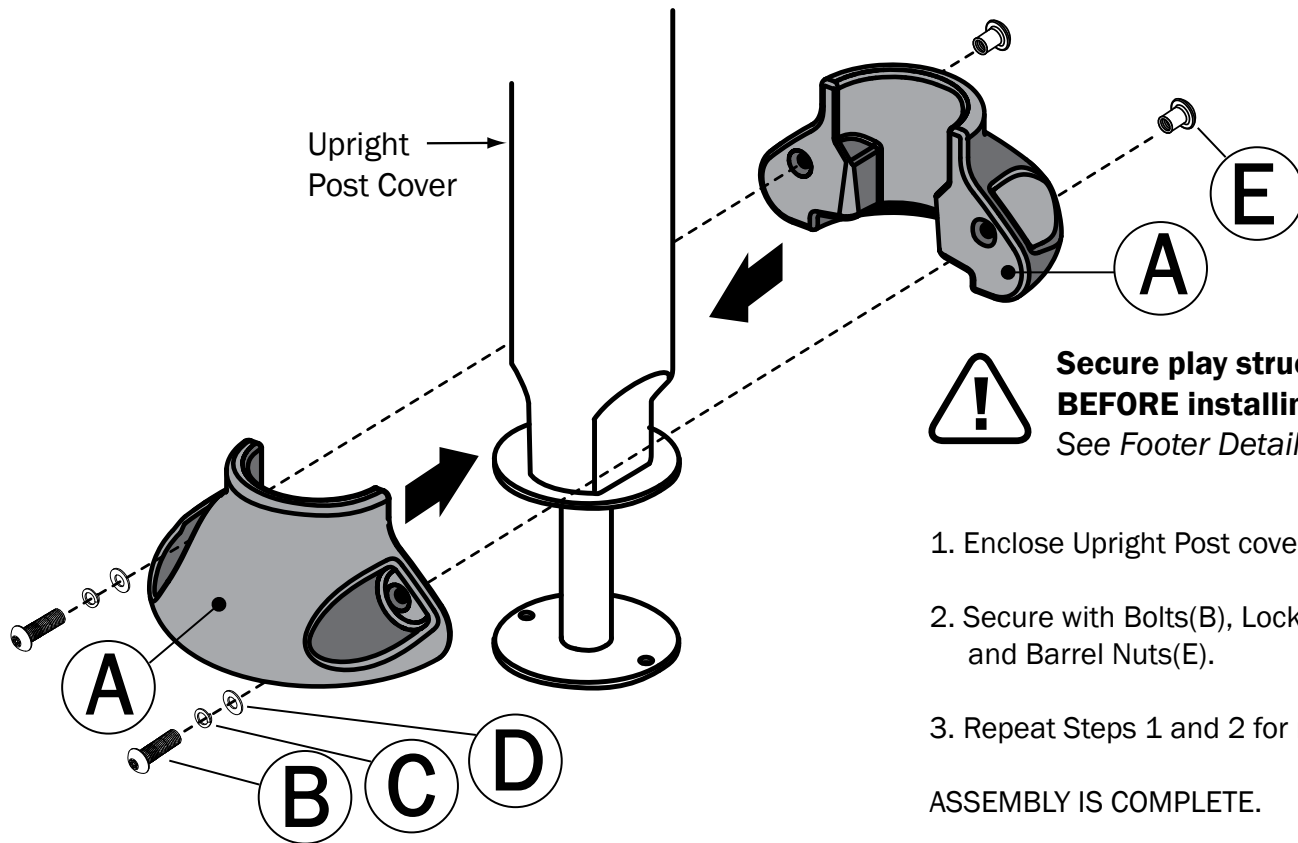

**Secure play structure to the ground BEFORE installing Footer Covers(A).**  
 See Footer Detail Page.

1. Enclose Upright Post cover with (2) Footer Covers(A).
2. Secure with Bolts(B), Lock Washers(C), Flat Washer(D) and Barrel Nuts(E).
3. Repeat Steps 1 and 2 for remaining Footer Covers.

ASSEMBLY IS COMPLETE.

# COMPONENT LIST\*

Letter	Description	Part Number	Quantity
A	Footer Covers	02-08-0009	14
B	Footers - 8"	02-08-0134 (0135-2")	10
C	Lower Post - 17.32" Long	02-08-0109	2
D	Lower Post - 73.62" Long	02-08-0113	2
E	Lower Post - 47.2" Long	02-08-0112	1
F	Lower Post - 31.5" Long	02-08-0110	2
G	Lower Post - 39.4" Long	02-08-0111	3
H	Upper Post - 32.68" Long	02-08-0136	1
I	Upper Post -34.6" Long	02-08-0115	2
J	Upper Post - 57.48" Long	02-08-0117	3
K	Upper Post - 23.23" Long	02-08-0137	1
L	Lower Post Cover - 7.5" Long	02-08-0050	1
M	Lower Post Cover - 15.38" Long	02-08-0028	2
N	Lower Post Cover - 22.88" Long	02-08-0029	2
O	Lower Post Cover - 30.25" Long	02-08-0030	2
P	Deck A	02-08-0006	2
Q	Deck B	02-08-0041	1
R	Deck C	02-08-0042	1
S	Bench Panel	02-08-0010	1
T	Bench Panel Handholds	02-08-0051	2
U	Platform	02-08-0022	1
V	Platform/Slide Mounting Bracket	02-08-0120	3
W	Extension Post - 8" Long	02-08-0118	3
X	Footer Plate	02-08-0122	5
Y	Vine Climber Extension Post -8" Long	02-08-0108 (0107-2")	2
Z	TouchMath Panel	02-08-0047	1
aa	Upper Post Cover - 7.38" Long	02-08-0033	4
bb	Slide Hood B	02-08-0053	1

Letter	Description	Part Number	Quantity
cc	Slide - Short Straight	02-08-0040	1
dd	Gear Panel	02-08-0046	1
ee	Climber Handhold Mounting Bracket	02-08-0102	1
ff	Climber Handhold - EVEN	02-08-0003	1
gg	Climber Handhold-ODD	02-08-0045	1
hh	Clock Panel	02-08-0048	1
ii	Arched Barrier Panel	02-08-0018	1
jj	Slide - Long Straight	02-08-0019	1
kk	Vine Climber Mounting Bracket	02-08-0106	1
ll	Vine Climber	02-08-0024	1
mm	Telescope Mounting Plate	02-08-0133	1
nn	Telescope Mounting Bracket	02-08-0105	1
oo	Telescope	02-08-0005	1
pp	90 Degree Connector	02-08-0100	3
qq	180 Degree Connector	02-08-0101	1
rr	Bongo Drum Mounting Bracket	02-08-0104	1
ss	Bongo Drum Support Bracket	02-08-0103	1
tt	Bongo Drum Mounting Bar	02-08-0126	1
uu	Bongo Drum	02-08-0025	1
vv	Rainwheel Mounting Bracket	02-08-0127	1
ww	Rainwheel	02-08-0026	1
xx	Upper Post Cover - 21.38" Long	02-08-0034	3
yy	Upper Post Cover - 28.88" Long	02-08-0035	2
zz	Entry Archway Leaves	02-08-0008	1
AA	Post Caps	02-08-0027	5
BB	Slide Hood A	02-08-0002	1
CC	Roof	02-08-0001	1

\*See Exploded View on next page

# MAINTENANCE CHECKLIST

Maintaining your playground equipment as well as its surrounding area is essential to minimizing the risk of injury to users as well as maximizing its useful lifespan. Manufacture recommends the following maintenance procedures be followed:

**On a daily basis:** A responsible individual should conduct a brief visual check for structural defects, signs of vandalism and litter of foreign matter that needs to be removed.

**On a weekly basis:** A responsible individual should complete this checklist. Any required repairs should be detailed on the separate **Detailed Maintenance Record**, and once they are completed, both should be filed for future reference. A separate file and form should be kept for each play structure at each location.

**IMPORTANT:** Always refer to - and comply with - the separate Safety Guidelines and ASTM and CPSC Guidelines. The play structure(s) should be barricaded so that it cannot be used while repairs are being completed.

	Item to be Checked (use the following page to record a brief description of the necessary repairs)	OK	Repairs Required	Date Repaired
<b>A.</b>	<b>Play Structures in General</b>			
	Post and component footings are not exposed, cracked or loose			
	1. Clamps show no signs of slippage, cracking or failure (if applicable)			
	2. Clamp drive rivets and hardware are secure (if applicable)			
	3. Welds are intact and free of cracks			
	a. Slide and Deck Enclosures			
	b. Overhead Activities			
	c. Climbers			
	4. No rust or corrosion			
	5. No splintered, cracked, gouged or otherwise deteriorated plastics; check for integrity of the plastic, keep plastic clean of any extraneous substances, verify that any deformation does not create entrapment as specified on ASTM-F-1487 Sec. 6.			
	6. No scratched, chipped or peeling paint			
	7. Metal parts show no visible cracks, bending, warping or breakage			
	8. No missing bolts, nuts, etc.			
	9. All bolts, nuts and fasteners are tight			
	10. All joints are secure (pay special attention to slides, flush-mounted decks and pipe connections)			
	11. All swivels, bearings, grease fittings and moving parts are well lubricated and not excessively worn (pay special attention to tot & strap swing seats)			
	12. No broken or missing parts			
	13. No sharp edges or unsafe protrusions (check metal corners, bolts, etc.)			
	14. No exposed mechanisms, junctions of moving parts or components that will pose possible pinch or crush points			
<b>B.</b>	<b>Play Events</b>			
	1. Plastic is not cut or cracked			
	2. All slide supports/anchors are intact and secure			
	3. All "S" hooks are closed and not excessively worn			
<b>C.</b>	<b>Swings</b>			
	1. All "S" Hooks are closed and not excessively worn			
	2. No exposed metal on swing seats			
	3. Swing chain is in good condition and not excessively worn, especially at connection points			
<b>D.</b>	<b>Surrounding Area</b>			
	1. Resilient surfacing material is not scattered or excessively worn (pay special attention to area at the end of slides and under swings)			
	2. Resilient surfacing material is adequately deep and retains its fall absorbing abilities as specified at time of installation			
	3. Border around playground is in good condition and has not come loose			
	4. No roots, rocks or other objects that may cause a tripping or injury hazard			
	5. Area is clean of litter (no broken glass or bottles, etc.)			

