



Crawl N Toddle

SKU: 622pg150



GENERAL COMMERCIAL PLAYGROUND SAFETY GUIDELINES

IMPORTANT: This structure is designed to comply with the ASTM F1487 standard for users 6 months through 23 months of age.

Maintaining your playground equipment and its surrounding area is essential to minimizing the risk of injury to users as well as maximizing its useful lifespan. Manufacture **STRONGLY** recommends that you follow these Safety Guidelines in conjunction with conducting periodic maintenance inspections using the accompanying *Playground Maintenance Checklist*.

When installing your playground, always consider local conditions. Good common sense works hand-in-hand with the instructions.

LOCATING YOUR PLAY STRUCTURE:

Comply with the following when choosing the location for your new equipment:

Equipment shall be positioned to eliminate conflicting traffic patterns. As a general rule, allow at least 3' of free space around the entire structure. This minimum area should be filled with the appropriate surface material. Read further for surfacing recommendations.

Never overlap the safety zones of adjacent equipment. All separate play equipment must have its own safety zone, and these cannot overlap. So, if you have an existing structure with a slide exit oriented toward your new one, add a minimum safety zone to that of the existing slide to determine how far away you need to be. Never install playground equipment near, around, or in conjunction with swimming pools, ponds, lakes, or any other bodies of water.

CHOOSING RESILIENT SURFACE MATERIAL:

According to ASTM guidelines: "Unacceptable material for use zones of play structures with fall heights of 18 in. or less shall include all hard or abrasive materials such as asphalt, concrete, terrazzo, or other materials with similar characteristics." Other standards apply for equipment with fall heights greater than 18 in.

Acceptable surfacing should be placed in the use zones of all equipment, as specified for each type of equipment, and at depths to meet the critical fall heights as specified by the U.S. Consumer Product Safety Commission, ASTM standard F-2373 and Canadian Standard CAN/CSA-Z-614.

For more information on the proper surfacing materials, call the CPSC hotline at 1-800-638-2772.

Worn surfaces around equipment should be restored. Concrete footing should never be exposed. Refer to the attached PLAYGROUND MAINTENANCE CHECKLIST.

Check for erosion and cratering of surfaces in heavy traffic areas and restore surfacing as necessary.

Surfacing leading to play opportunities for children with disabilities should be firm, stable, slip resistant, and resilient.

OVERHEAD OBSTRUCTIONS:

Overhead obstructions (for example, exterior obstructions such as tree limbs and interior lights) within the use zones of play structures shall be a minimum of 84 inches (2130 mm) above each designated play surface outdoors and a minimum of 48 inches (1220mm) above each designated play surface indoors.

All overhead utility line clearances above outdoor supervised and outdoor unlimited access settings shall comply with all local, state, and national codes, such as the National Electrical Safety Code. For specific equipment fall zone requirements, refer to the CPSC and ASTM F1487 and use the more stringent of the two.

CATCH POINT & PROTRUDING HARDWARE:

There should be no dangerous pieces of hardware, such as protruding bolt ends or narrow gaps in metal connections. Exposed hardware can cut or puncture skin and catch clothing drawstrings, which could strangle a child.

All protruding nuts and bolts should be eliminated; sharp edges on pipes should be capped or removed. Check for bent, broken, or severely worn pipe and replace. Examine play system for foreign objects, holes, and rough edges.

TRIPPING HAZARDS:

There should be no exposed concrete footings, abrupt changes in surface elevations, tree roots, tree stumps, or rocks, which can trip children and adults. Check for trip hazards, such as the support posts, or environmental trip hazards, such as rocks or roots in the play area. Make all necessary improvements or repairs.

AFTER THE EQUIPMENT IS IN USE:

- Never add components not intended for use with this product.
- Never install other play equipment, fencing, landscaping, etc., that encroach upon the safety zones of this equipment.
- Check overall stability and rigidity of all play equipment.
- Check for proper assembly, installation and ground anchoring.
- Check and re-tighten all fasteners after the first few days of use and again after three weeks of use. Thereafter, exercise normal maintenance procedures. Use of a thread-locking compound on the threads of bolts can prevent persistent loosening.

ROUTINE MAINTENANCE:

Regularly inspect and maintain your playground equipment and its surrounding area to help ensure the safety of the user. Proper maintenance of Early Play equipment includes using the accompanying **Playground Maintenance Checklist** found in this booklet to identify areas requiring repairs or replacement, and barricading the equipment to prevent use while corrections are being made.

As the Owner/Operator of the equipment, you should establish and maintain detailed installation, inspection, maintenance, and repair records for each public-use playground equipment area. Find out if your playground has a designated official who periodically inspects the play equipment for preventative maintenance. This includes but is not limited to: replacing missing, broken or worn-out components; securing hardware; checking for deterioration in the metal or plastic materials; maintaining the proper depth of surfacing material; and cleaning up debris.

The following are some regular maintenance areas of note:

- Check for and repair damage caused by wear or vandalism, a major factor in injury causing situations.
- Proper maintenance of Early Play equipment requires regular tightening of all bolts, nuts, set screws and other hardware.
- All equipment should be free of rust and repainted with an appropriate lead-free paint whenever necessary to deter rusting. This should also be done for any chipped or peeling areas.
- Regular checking of all parts, casting, etc., should be made. If part is broken or worn it should be replaced immediately.
- Check for missing or broken parts and repair as necessary.
- Check to be sure there is free movement on moving attached parts.

Continued on next page >

- Check for hard surfaces and correct. Refer to CPSC surfacing requirements.
- Check for surfacing material that is worn or scattered and restore.
- Debris, broken glass, trash, or other foreign objects within or on the play area/equipment should be removed.
- Check for poor drainage areas and repair.
- Check concrete footings to see if they are exposed, cracked, or loose in the ground and repair as necessary.
- Check crush points (exposed mechanisms, junctures of moving components) and eliminate.
- Check for broken supports or anchors. Check for stability in ground. Structures should not be easily swayed; connections should be solid and adequately secured.
- Check all posts in ground for corrosion below grade.
- When flexible components are anchored in the ground, check and make sure anchoring devices are below the level of the playground.
- Check for visible cracks, bending, warping, rusting, or breakage of any component and repair as needed.
- Check for accessible sharp edges or points. Check for protruding bars, bolts, nuts, etc. Eliminate these conditions.
- Check for exposed ends of tubing that should be covered with plugs or caps.
- Check for loose bolts, nuts, etc. and tighten.

MAINTENANCE CHECKLIST

Maintaining your playground equipment as well as its surrounding area is essential to minimizing the risk of injury to users as well as maximizing its useful lifespan. Manufacture recommends the following maintenance procedures be followed:

On a daily basis: A responsible individual should conduct a brief visual check for structural defects, signs of vandalism and litter of foreign matter that needs to be removed.

On a weekly basis: A responsible individual should complete this checklist. Any required repairs should be detailed on the separate **Detailed Maintenance Record**, and once they are completed, both should be filed for future reference. A separate file and form should be kept for each play structure at each location.

IMPORTANT: Always refer to - and comply with - the separate Safety Guidelines and ASTM and CPSC Guidelines. The play structure(s) should be barricaded so that it cannot be used while repairs are being completed.

	Item to be Checked (use the following page to record a brief description of the necessary repairs)	OK	Repairs Required	Date Repaired
A.	Play Structures in General			
	1. Post and component footings are not exposed, cracked or loose			
	2. Welds are intact and free of cracks			
	3. No rust or corrosion			
	4. No splintered, cracked, gouged or otherwise deteriorated plastics; check for integrity of the plastic, keep plastic clean of any extraneous substances, verify that any deformation does not create entrapment as specified on ASTM-F-2373.			
	5. No scratched, chipped or peeling paint			
	6. Metal parts show no visible cracks, bending, warping or breakage			
	7. No missing bolts, nuts, etc.			
	8. All bolts, nuts and fasteners are tight			
	9. All joints are secure (pay special attention to flush-mounted decks and pipe connections)			
	10. No broken or missing parts			
	11. No sharp edges or unsafe protrusions (check metal corners, bolts, etc.)			
	12. No exposed mechanisms, junctions of moving parts or components that will pose possible pinch or crush points			
B.	Play Events			
	1. Plastic is not cut or cracked			
C.	Surrounding Area			
	1. Resilient surfacing material is not scattered or excessively worn			
	2. Resilient surfacing material is adequately deep and retains its fall absorbing abilities as specified at time of installation			
	3. Border around playground is in good condition and has not come loose			
	4. No roots, rocks or other objects that may cause a tripping or injury hazard			
	5. Area is clean of litter (no broken glass or bottles, etc.)			

Warranty

Manufacture warrants its products to be free from defects in materials and/or workmanship, subject to normal usage and installation, for a period of 1-year from the date of shipment to the original purchaser. In the event of a claim under this warranty, manufacture will replace the component at no cost within the the first 12 months from date of shipment to the original customer. Equipment not specifically addressed in the following paragraphs is also subject to this limited 1 year warranty against defects in materials and/or workmanship.

FIFTEEN-YEAR LIMITED WARRANTY ON METAL PARTS

Manufacture provides a limited warranty on metal decks, steps, stairs, rails, pipes, support posts, rungs, loops, to be free from defects in materials or workmanship against structural failure which causes the product to become unfit for its intended use, subject to normal usage and installation, for a period of 15 years from the date of shipment to the original customer.

TEN-YEAR LIMITED WARRANTY ON UPRIGHT POSTS

Manufacture provides a limited warranty on Early Play metal posts and HDPE Panels to be free from defects in materials or workmanship against structural failure which causes the product to become unfit for its intended use, subject to normal usage and installation, for a period of 10 years from the date of shipment to the original customer.

FIVE-YEAR LIMITED WARRANTY ON GROUND-MOUNT METAL PARTS

Manufacture provides a limited warranty on metal footers, inground footers, surface mount plates, ground spikes, slide and climber mounting posts and plates to be free from defects in materials or workmanship against structural failure which causes the product to become unfit for its intended use, subject to normal usage and installation, for a period of 5 years from the date of shipment to the original customer.

ONE-YEAR LIMITED WARRANTY ON HARDWARE

Manufacture provides a limited warranty on hardware to be free from defects in materials or workmanship against structural failure due to breaking or shearing, subject to normal usage and installation, for a period of 1 year from the date of shipment to the original customer.

Warranty Exclusions

All warranties specifically exclude damage caused by man-made or natural disasters, vandalism, negligence, improper installation or improper use, modification, changes in appearance resulting from weathering, scratches, dents, discoloration, normal wear and tear, or marring as a result of public or private use.

Claims are limited to replacement of equipment only and do not include any costs associated with labor, removal or installation of the original or replacement product.

Warranties are valid only if products are installed and maintained in accordance with manufacture installation instructions and use of approved parts.

This warranty is applicable to the original owner only. Warranties are non-transferable.

Claim Procedure: To make a warranty claim, send your statement of claim, photos of defective equipment, and the original order number to Customer Service.

Within 60 days of notice of claim under warranty. Manufacture will make arrangements to replace the damaged product. Manufacture will cover freight costs within the continental United States. The manufacture is not responsible for freight costs associated with products located outside the continental United States. Manufacture reserves the right to inspect all products identified as defective. Photos of defective equipment may be required to accompany warranty claims.

Since warranty limitations and exclusions may vary from state to state, you should check any specific warranty rights in your state.

GENERAL INTRODUCTION TO INSTALLATION INSTRUCTIONS

IMPORTANT! Please read the entire Installation Instructions packet before beginning the installation.

The manufacture has designed product to take advantage of all Consumer Product Safety Commission (CPSC) and ASTM guidelines in force at the time of purchase in an effort to prevent playground accidents. However, because studies have shown most playground injuries result from accidental falls, you, as the new owner of this equipment are responsible for providing an acceptable play surface under and around all playground equipment. Please refer to the accompanying Safety Guidelines as well as CPSC guidelines and this document for examples of such surfacing.

We would like to provide the following suggested guidelines for your play environment:

- Refer to the Use Zone and note the Minimum Area required shown for this structure. This area must be filled with acceptable play surface material, and must be clear of all obstacles, including but not limited to trees, curbing, sidewalk, fence, other play equipment, rocks, and landscaping, etc.
- According to ASTM guidelines: "Unacceptable materials for use zones of play structures with fall heights of 18" or less shall include all hard or abrasive materials such as asphalt, concrete, terrazzo, or other materials with similar characteristics." Other standards apply for equipment with fall heights greater than 18".
- Acceptable play surfaces include: sand, mulch, fine gravel or shredded belt-less tires, if installed at the appropriate depths per CPSC guidelines for play surfacing.
- Close supervision of children playing on or around the structure is strongly recommended, along with classroom and/or home instructions on safer behavior on the playground equipment. The full supervision of playgrounds is the responsibility of the owner once the play structure has been properly installed.

TOOLS REQUIRED:

Manufacture supplies only the special wrenches and bits required to fasten the "tamper-resistant" hardware and components. You will need common wrenches as well as a drill, phillips head screw driver, utility knife, rubber mallet, and a tape measure.

INSTALLATION GUIDELINES:

1. Compare all parts received to the packing list. Notify us immediately of any missing parts.
We are not responsible for parts discovered missing over 10 days after receipt of the shipment.
2. Refer to the Use Zone to ensure this structure will fit into your actual site area. Note the Minimum Area Required measurements to determine clear space required. A minimum of 3' clearance is required between any obstacles and your structure.
3. Site selection should include considerations of what is a safe and appropriate play area:
 - A level and clear site is ideal, free of power lines or electrical equipment.
 - Do not install play equipment near any bodies of water.
 - If adjacent to a street with traffic, ensure adequate fencing acts as a barrier to children running into danger.
4. Site layout should include accurate measurement and marking of all footings prior to any installation. Use the dimensions shown between footings on the Use Zone to plot out the actual footprint of the play structure before doing any digging. Also locate any freestanding play equipment in the same way, providing the necessary clearance between the equipment as well as any fences, trees, etc. Ensure at this time you have enough total space for the equipment to be installed.

WARNING LABEL APPLICATION INSTRUCTIONS

The enclosed Warning Label must be affixed to your playground equipment.

INSTRUCTIONS:

1. Fully assemble and install your Early Play playground equipment per the accompanying installation instructions.
2. When installation of the equipment is complete, and prior to allowing use of the equipment, refer to the installation instructions to install the Warning Label on the structure.
3. Fully clean the mounting plate surface to receive the label with soap and water, and ensure that no oils, film, or dirt remain.
4. Allow surface to dry fully. Apply the Warning Label, smoothing over the surface with a clean cloth so there are no air bubbles present.

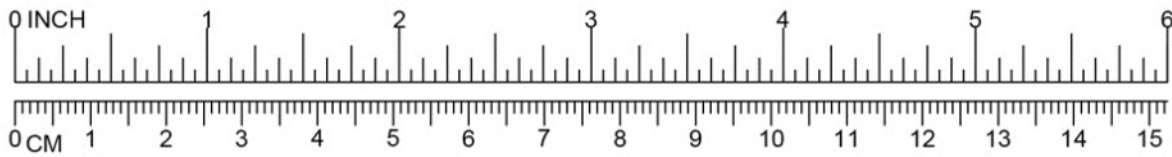

3/8" B.H.C.S. Bolts (Hardware is Actual Size)

Hardware*

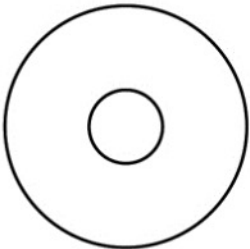
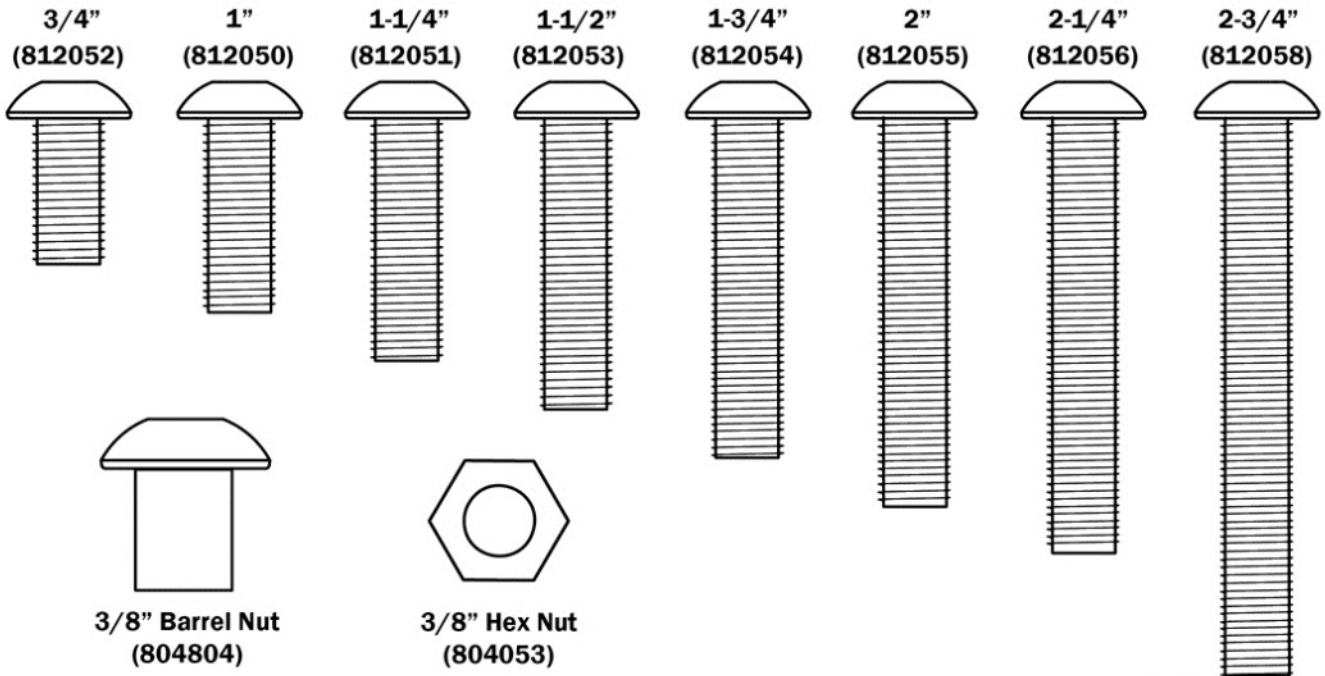

3/8" Flat Washer (1-1/4" O.D.)
(817424)

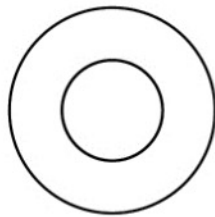

1/2" Flat Washer
(817412)

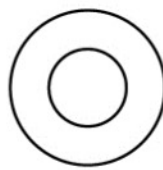

3/8" Flat Washer
(817410)

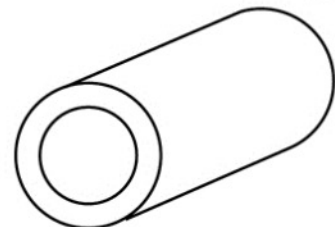

Bronze Bushing (1" Long)
(818317)



Plastic Cap
(304074)



Plastic Washer
(304073)



#4 x 1/2" Long Pan Head Screw
(809400)

*Note: Your play system may not require all hardware listed.



Utility Knife

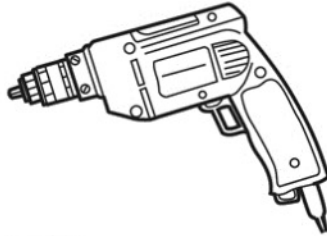

Drill



Tape Measure

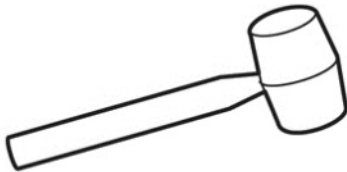

Rubber Mallet

**TOOLS
REQUIRED**



**Phillips Head
Screw Driver**

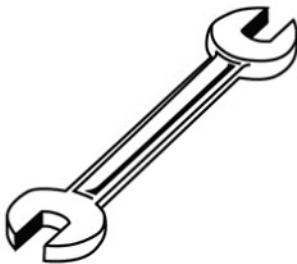

Wrench 9/16"

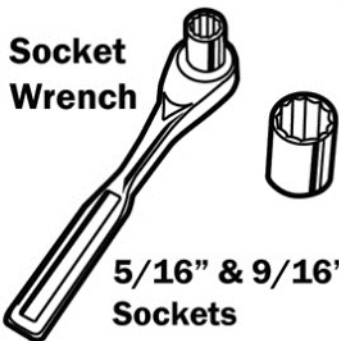

**Socket
Wrench
5/16" & 9/16"
Sockets**



**#45 Torx Head
Wrenches & Bits
(included)**

UP133 CRAWL & TODDLE (STANDARD) NATURAL

Parts List		
DESCRIPTION	QTY	PART NUMBER
COATED DECK	1	403097
COATED RAMP	1	403096
FRONT WALL	1	403086**
BACK WALL	1	403087**
COATED STEPS	1	403095
90° ANGLE BRACKET	2	403098
LEFT WALL	1	403088**
RIGHT WALL	1	403089**
CLEAR BUBBLE	1	304423
CRUISE RAIL	1	403091
SQUARE	2	403090**
SPIRAL WHEEL	2	403092**
TRIANGLE	2	403094**
CIRCLE FRAME	1	403093**
CIRCLE MIRROR	2	169758
WARNING LABEL PLATE	1	403215
HARDWARE COMPLETE	1	403032
3/8" x 3/4" CARRIAGE BOLT	4	800252*
3/8" x 3/4" P.B.H.C.S. w/PATCH	4	812052*
3/8" x 1" P.B.H.C.S. w/PATCH	2	812050*
3/8" x 1 1/2" P.B.H.C.S. w/PATCH	4	812053*
3/8" x 1 3/4" P.B.H.C.S. w/PATCH	26	812054*
3/8" x 2 1/4" P.B.H.C.S. w/PATCH	1	812056*
3/8" x 2 3/4" P.B.H.C.S. w/PATCH	2	812058*
3/8" x 3 1/4" P.B.H.C.S. w/PATCH	3	812060*
3/8" HEX NUT	26	804053*
3/8" FLAT WASHER (1 1/4" O.D.)	30	817424*
3/8" BARREL NUT	18	804804*
3/8" FLAT WASHER	49	817410*
1/2" I.D. BRONZE BUSHING	3	102820*
LARGE GEAR	1	403109*
SMALL GEAR	2	403110*
#4 x 1/2" PAN HEAD SCREW	4	809400*
6-23 MONTH WARNING LABEL	1	403214*
3/8" PIN-IN TORX BIT TT-45	2	812655
3/8" PIN-IN TORX KEY-TT-45	2	812658

Unless Otherwise Specified, All Units of Measure are Each

**Items listed below Hardware Complete line are included with Hardware Complete Number*

****Included in HDPE package 403105**

Warning: During Installation, Hardware And Small Parts Are Choking Hazards For Young Children. Store Unused Parts Appropriately Until Assembly Is Completed. Once Assembly Is Completed, Remove Any Unused Parts From The Play Environment And Dispose/Save Them In A Secure Location. Any bolt end protruding more than two full threads beyond the face of the nut causes risk of clothing entanglement.

Promptly cut-off flush, file smooth, and treat to prevent corrosion.

UP133 used with UP134 In Ground Package or UP135 Surface Mount Package. (Both Sold Separately)

UP133 CRAWL & TODDLE (STANDARD) NATURAL

SPECIFICATIONS:

HDPE Panels:

Panels shall be precision cut from a single solid sheet of .75" thick UV-stabilized extruded high-density polyethylene with colors molded in. The material will have a density of 60 lbs/ft³ and a tensile strength of 4400 PSI (30 Mpa) as determined per procedure C of ASTM D1928. All edges shall have radiuses and all corners rounded for safe play.

Plastisol Coated Steps, Deck and Ramp:

All metal deck platforms, steps and ramps, are plastisol-coated. Each part is chemically washed and completely submerged in a special heat-activated primer and allowed to dry. Parts are then pre-heated and immersed in liquid polyvinyl-chloride (plastisol). The PVC coating shall have a typical thickness of .080" to .120", and a hardness of Shore A 83 +/-5 normal durometer range. This material is classed as "Self Extinguishing", meets or exceeds automotive specifications NVSS302, and contains ultraviolet inhibitors to help prolong the life of the coating. Standard color is brown, with optional colors available. The following characteristics apply:

Tensile Strength - 2,800 psi Elongation
- 290 %
Tear Strength - 420 lbs/in

Cruise Rail:

Shall be 1-1/16" O.D. x 15 gauge (.075" thick) galvanized steel tubing and shall be coated after fabrication with a custom formula of TGIC polyester powder coating

Clear Bubble:

Shall be 1/4" thick transparent polycarbonate.

Flat Mirror:

Shall be 1/8" thick polycarbonate.

Large and Small Gears:

Shall be high-density polyethylene with colors molded in

90° Angle Bracket:

Shall be 3/16" x 2" Hot Rolled Steel. 90 Degree Angle Bracket will have baked on polyester powder-coated finish after fabrication.

Hardware:

All nuts, bolts, screws, inserts, and lockwashers used in the assembly of all play equipment shall be stainless steel, yellow dichromate plated steel, blue-coat plated steel, mechanically galvanized or powder coated/yellow dichromate plated steel. All primary fasteners shall be 304 alloy stainless steel. Fasteners with yellow dichromate treatment have an electro-deposited, 99.9% pure zinc substrate applied from a specially formulated solution sealed with a yellow dichromate top coat designed to work in conjunction with the zinc plating. Yellow dichromate has a 320% longer life to white corrosion and 275% longer to red corrosion than does hot-dip galvanizing. Stainless steel fasteners shall be button pin-in head, hex socket cap screws with a two-part epoxy locking patch added to the threads. The two-part locking patch shall consist of one part resin and one part catalyst which are activated during installation. After curing, the material shall require a minimum of five times the installation torque to remove the fastener. Manufacturer shall provide special installation tools for pinned fasteners.

UP133 CRAWL & TODDLE (STANDARD) NATURAL

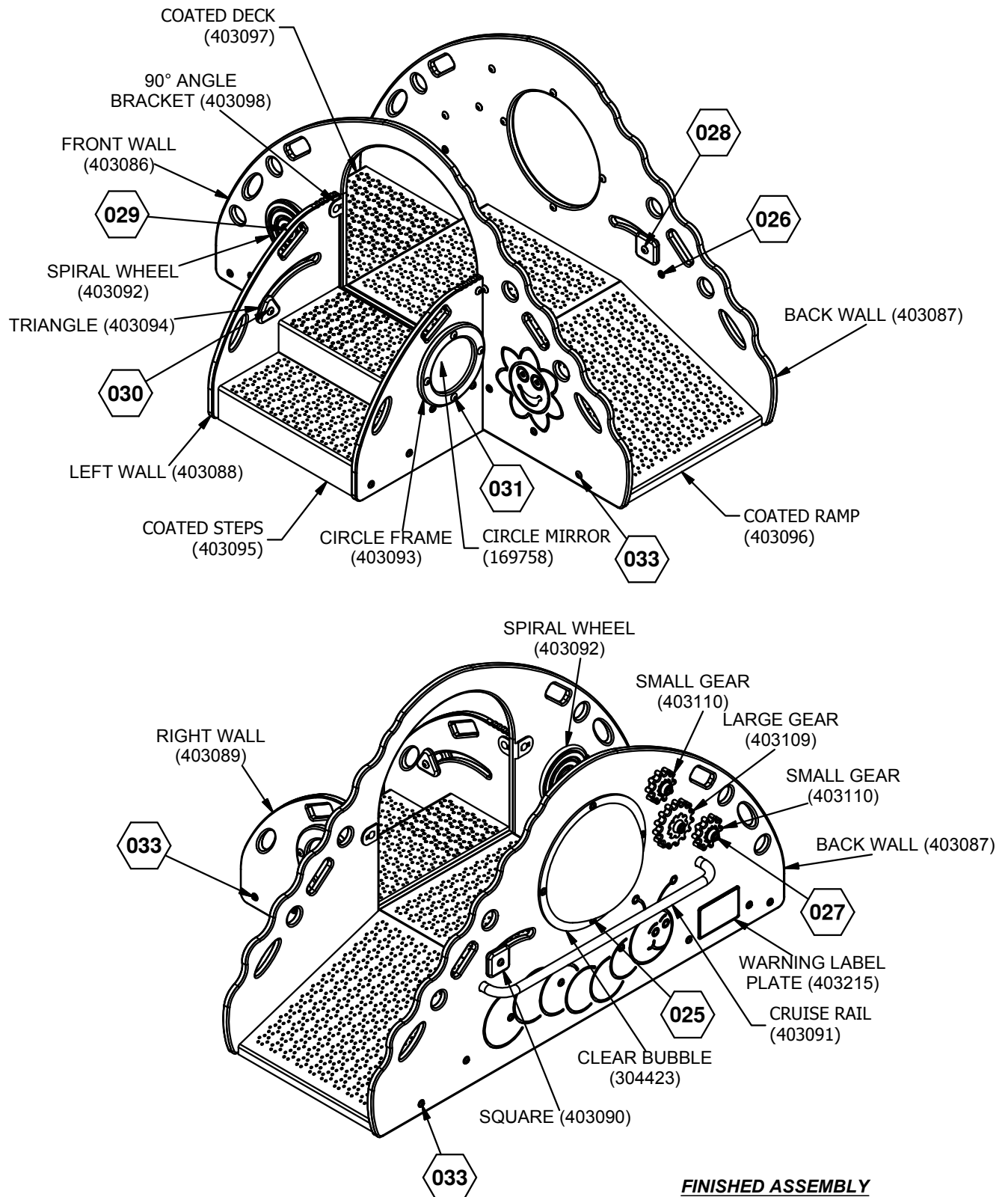

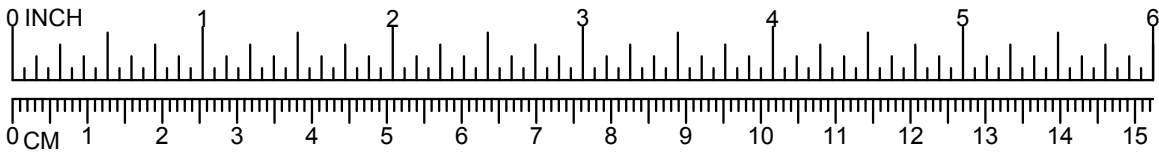

UP133 CRAWL & TODDLE (STANDARD) NATURAL STEP 1

1. Make sure on Coated Deck, Ramp and Steps that all holes are clear of plastisol coating.
2. Attach Coated Deck to Coated Ramp using 3/8" x 1" P.B.H.C.S. w/Patch, 3/8" Flat Washer (1 1/4" O.D.), and 3/8" Hex Nut. See Detail 032.

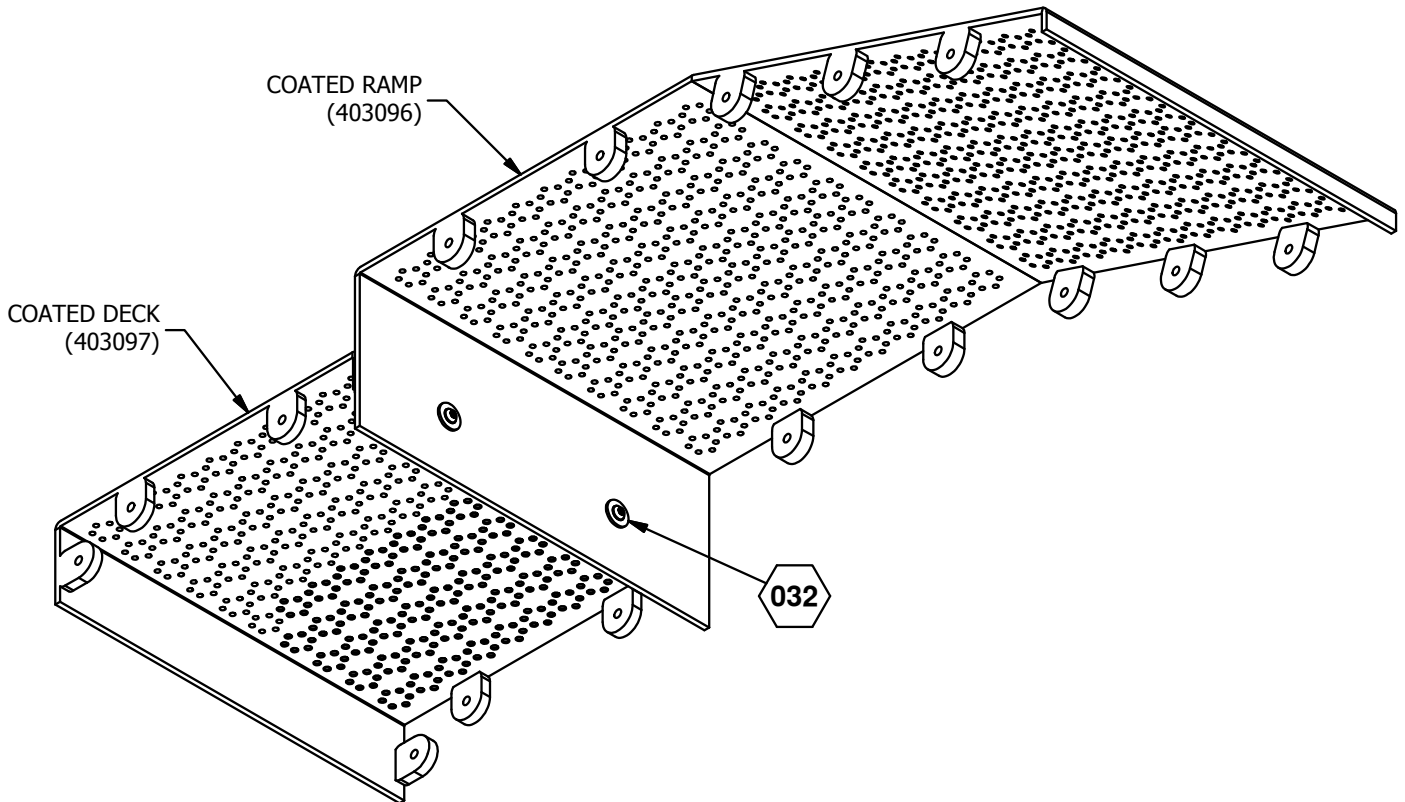
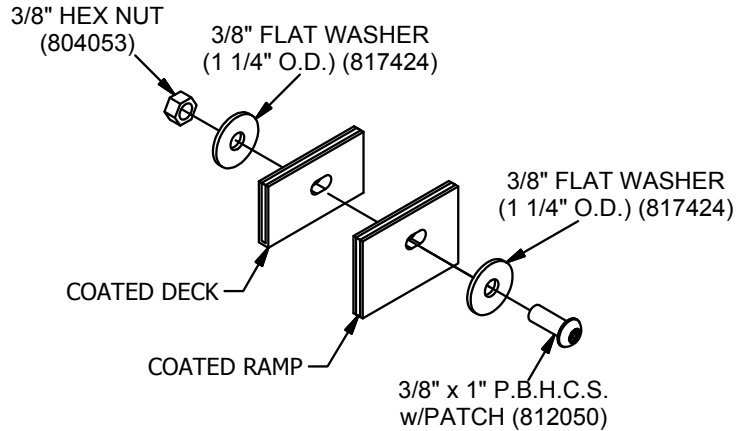

UNDERNEATH VIEW

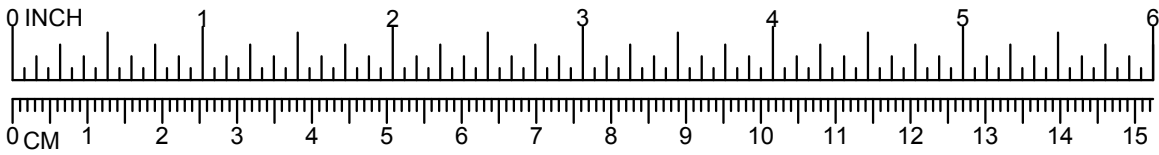

UP133 CRAWL & TODDLE (STANDARD) NATURAL STEP 2

1. Attach assembled Deck and Ramp to Front Wall and Back Wall using 3/8" x 1 3/4" P.B.H.C.S. w/Patch, 3/8" Flat Washer, 3/8" Flat Washer (1 1/4" O.D.), and 3/8" Hex Nut. See Detail 033.

NOTE: IF INSTALLING IN GROUND OR SURFACE MOUNT PACKAGES REFER TO UP134 OR UP135 INSTALLATION SHEETS NOW.

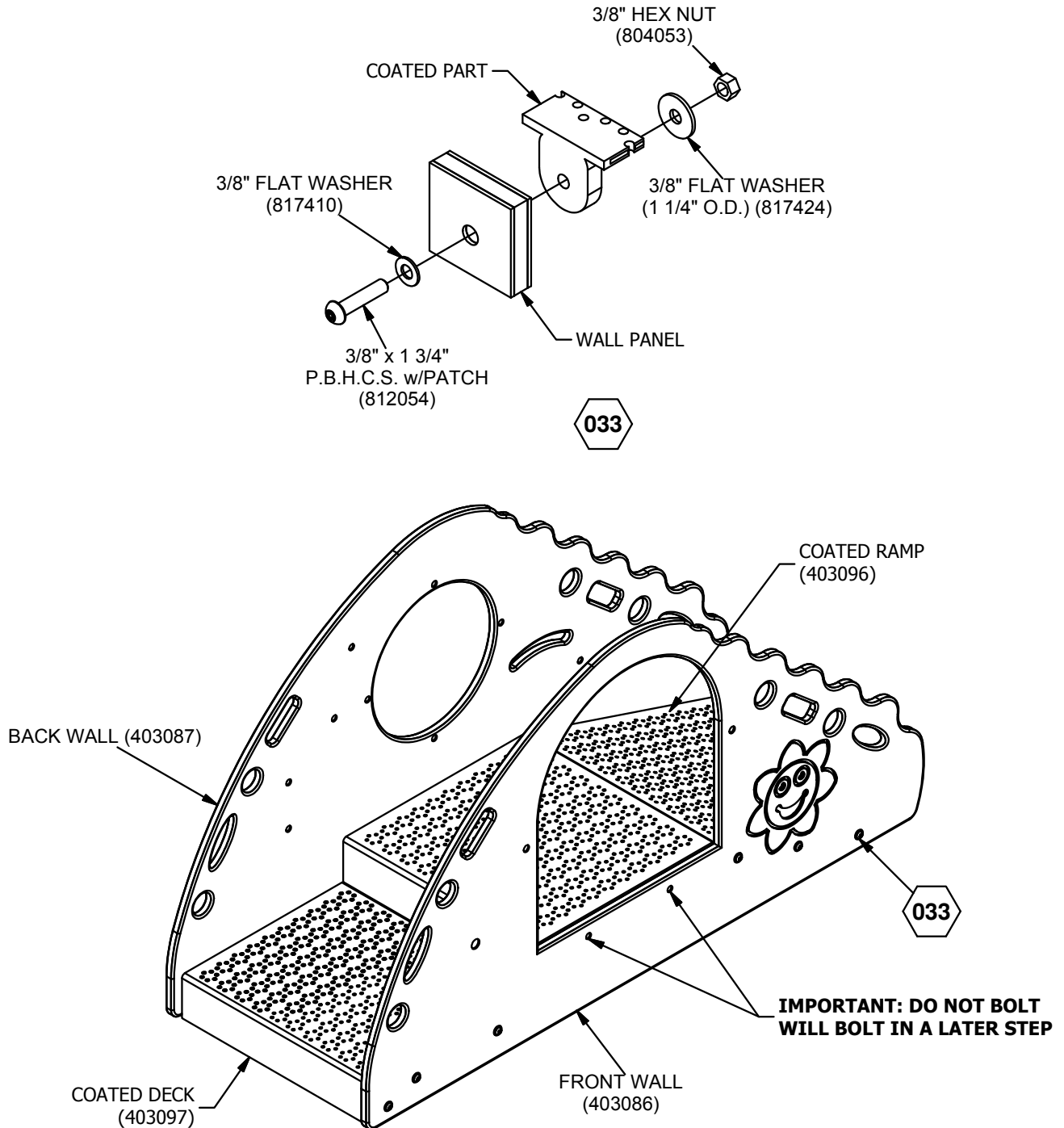

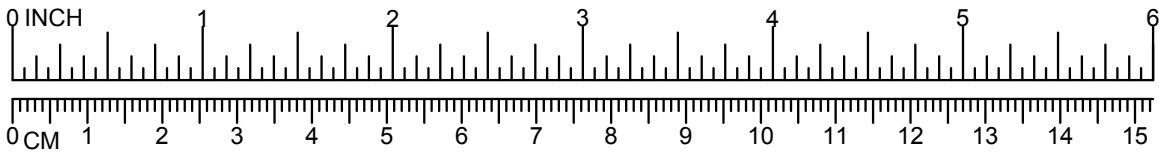

UP133 CRAWL & TODDLE (STANDARD) NATURAL STEP 3

1. Attach Left and Right Side Wall to Coated Steps using 3/8" x 1 3/4" P.B.H.C.S. w/Patch, 3/8" Flat Washer, 3/8" Flat Washer (1 1/4" O.D.), and 3/8" Hex Nut. See Detail 033.
2. Attach Left and Right Side Wall to Front Wall using 90° Angle Bracket, 3/8" x 3/4" Carriage Bolt, and 3/8" Barrel Nut. See Detail 024.

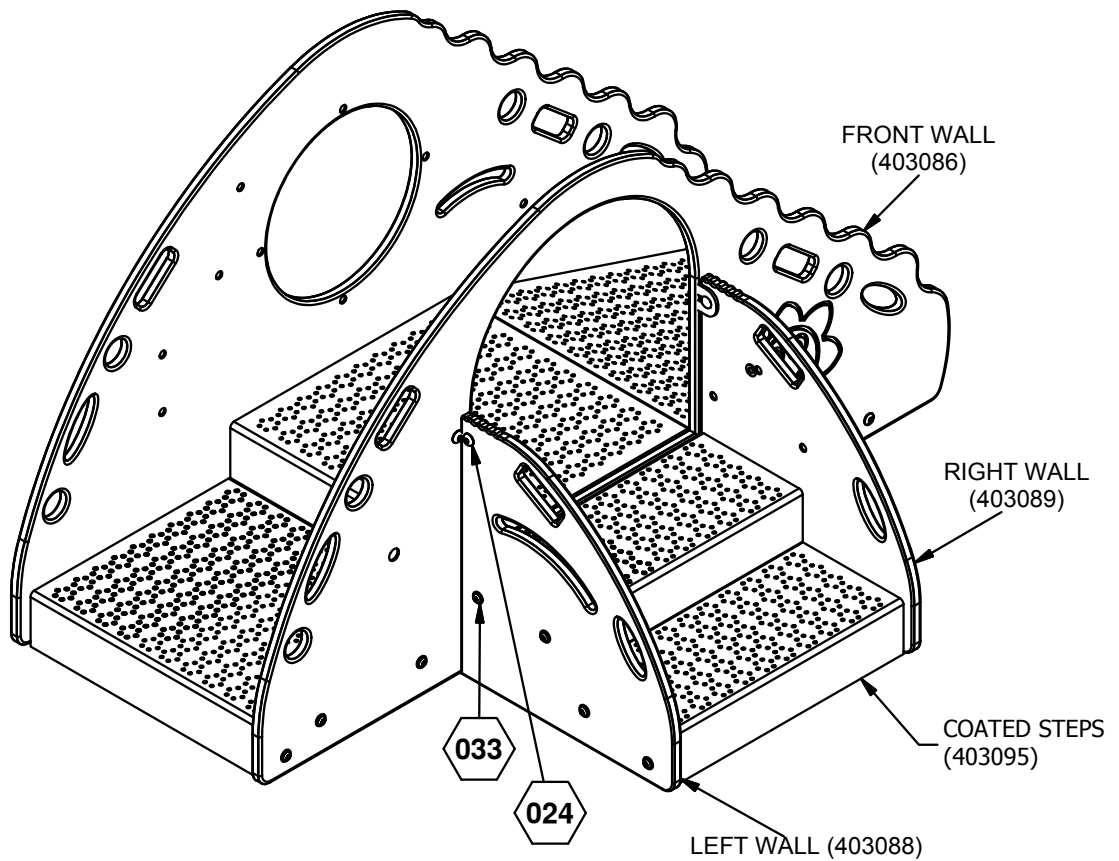
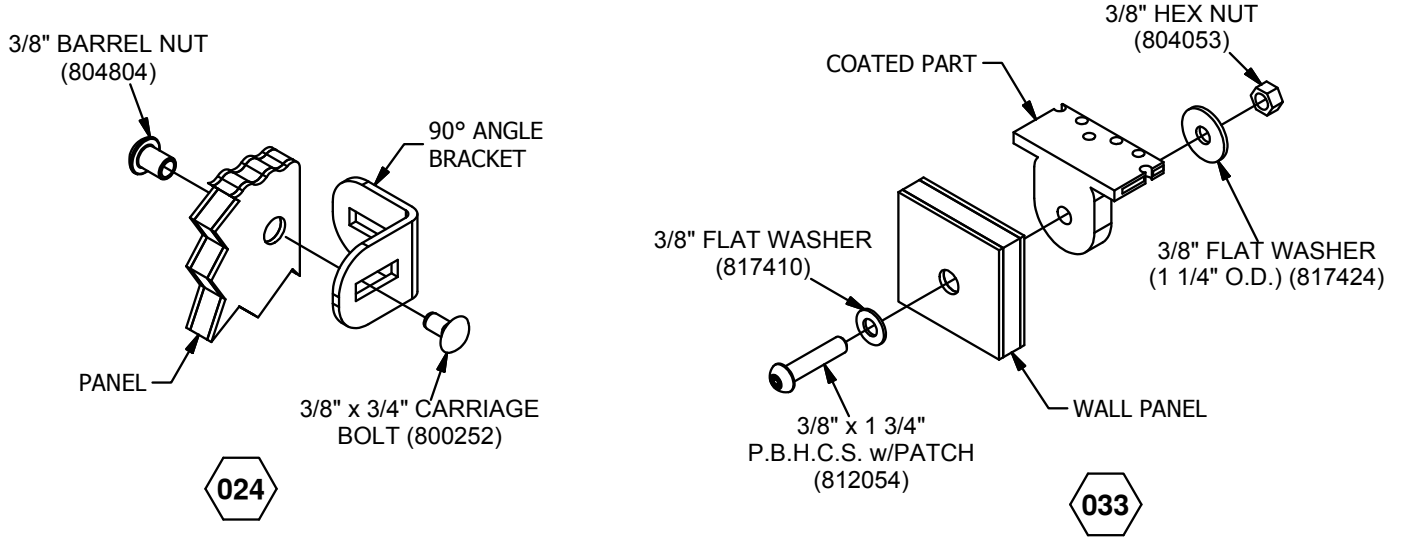

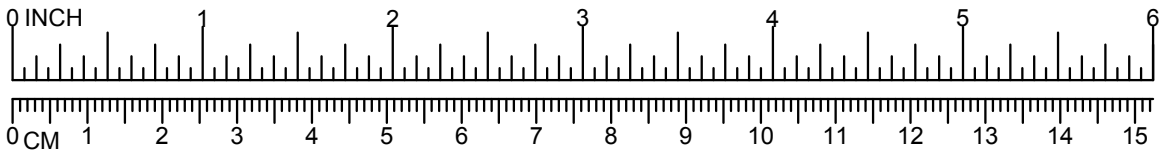

UP133 CRAWL & TODDLE (STANDARD) NATURAL STEP 4

1. Attach Coated Steps to Front Wall using 3/8" x 1 3/4" P.B.H.C.S. w/Patch, 3/8" Flat Washer (1 1/4" O.D.), and 3/8" Hex Nut. See Detail 034.

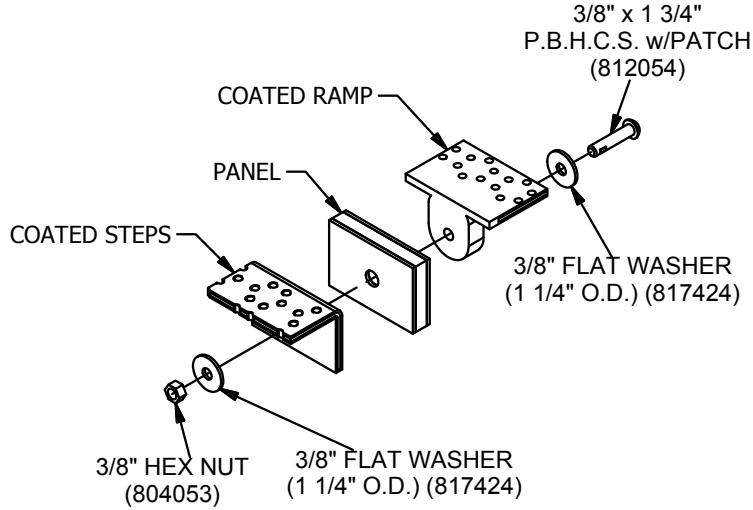

034

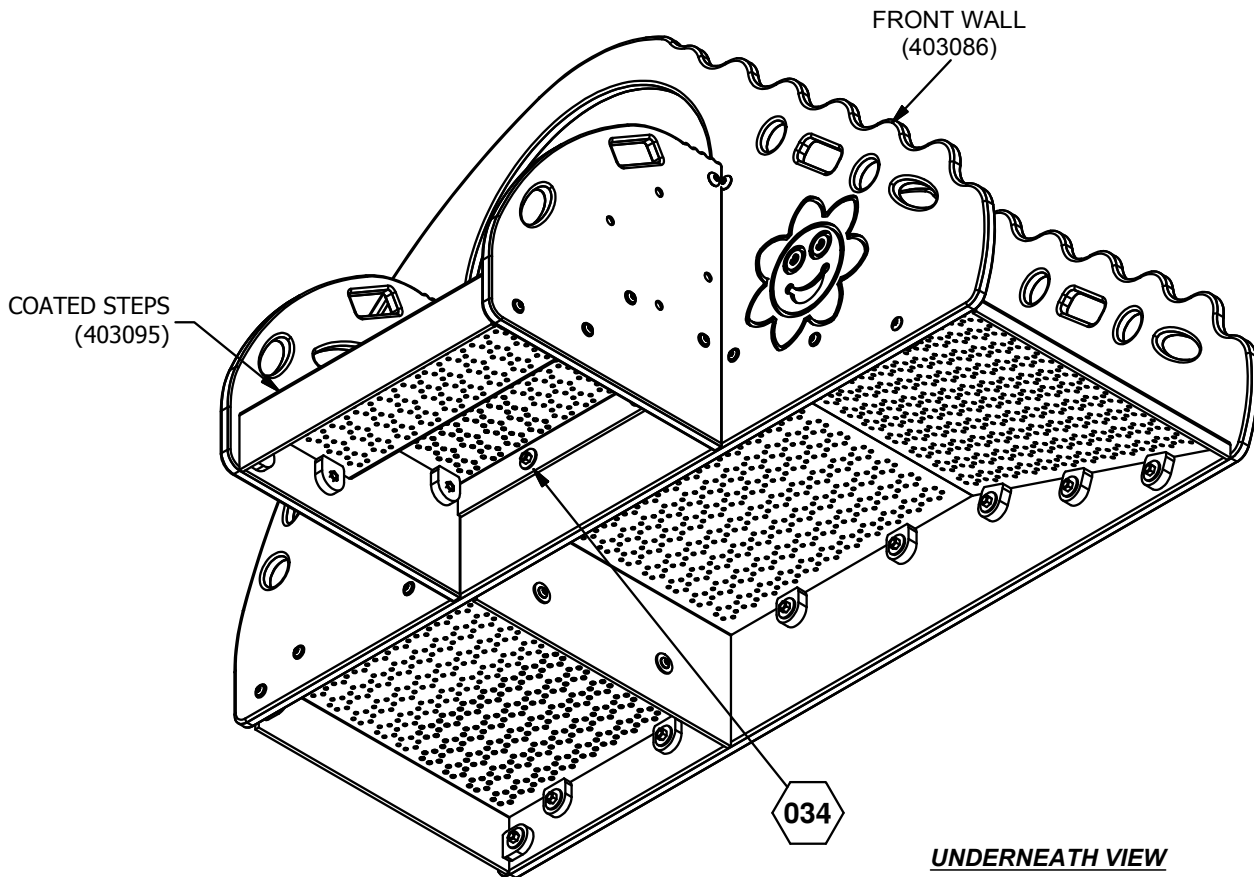

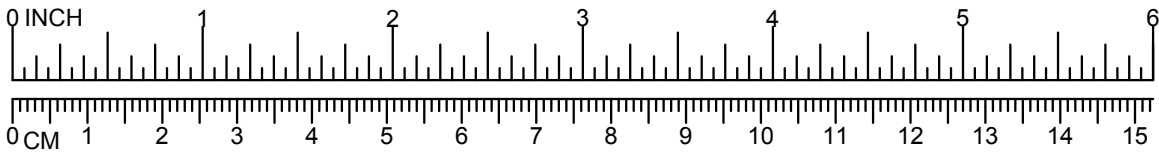

UP133 CRAWL & TODDLE (STANDARD) NATURAL STEP 5

1. Attach Clear Bubble to Back Wall using 3/8" x 3/4" P.B.H.C.S. w/Patch, 3/8" Flat Washer, and 3/8" Barrel Nut. See Detail 025.
2. Attach Cruise Rail to Back Wall using 3/8" x 1 3/4" P.B.H.C.S. w/Patch and 3/8" Flat Washer. See Detail 026.

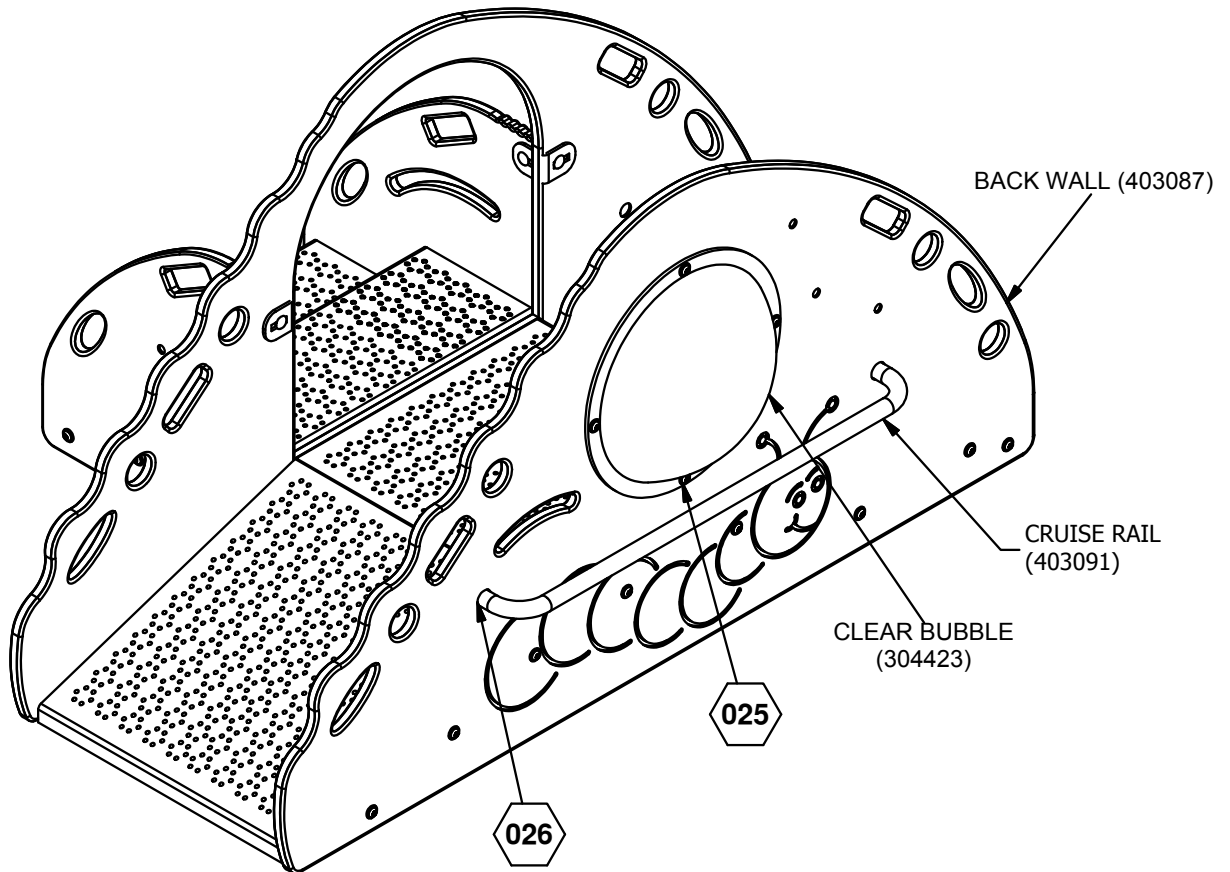
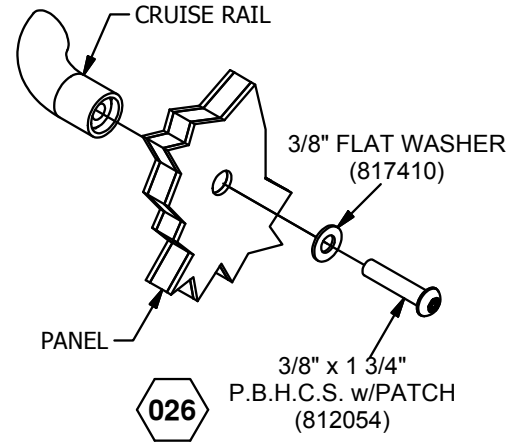
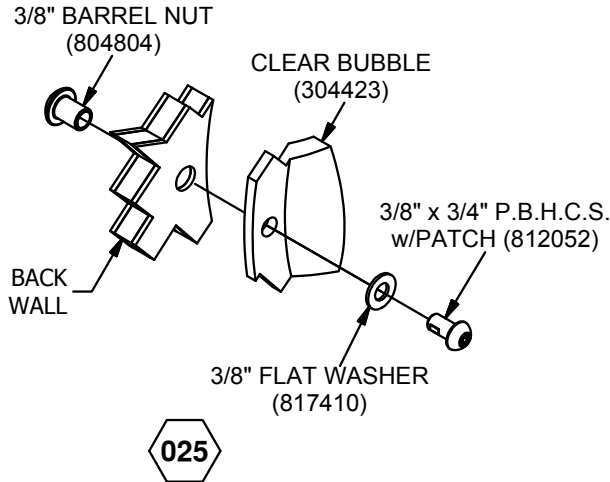

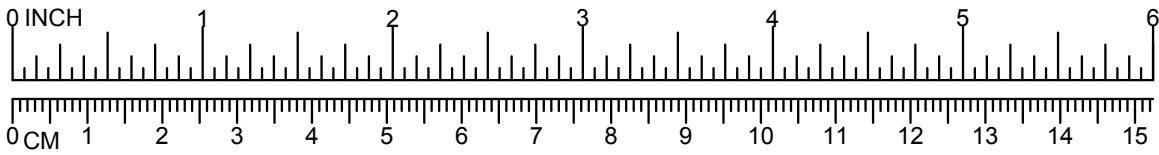

UP133 CRAWL & TODDLE (STANDARD) NATURAL STEP 6

1. Attach Small and Large Gears to Back Wall using 3/8" x 3 1/4" P.B.H.C.S. w/Patch, 3/8" Flat Washer, and 3/8" Barrel Nut. See Detail 027.
2. Attach Square to Back Wall using 3/8" x 2 3/4" P.B.H.C.S. w/Patch, 3/8" Flat Washer, 1/2" I.D. Bronze Bushing, and 3/8" Barrel Nut. See Detail 028.

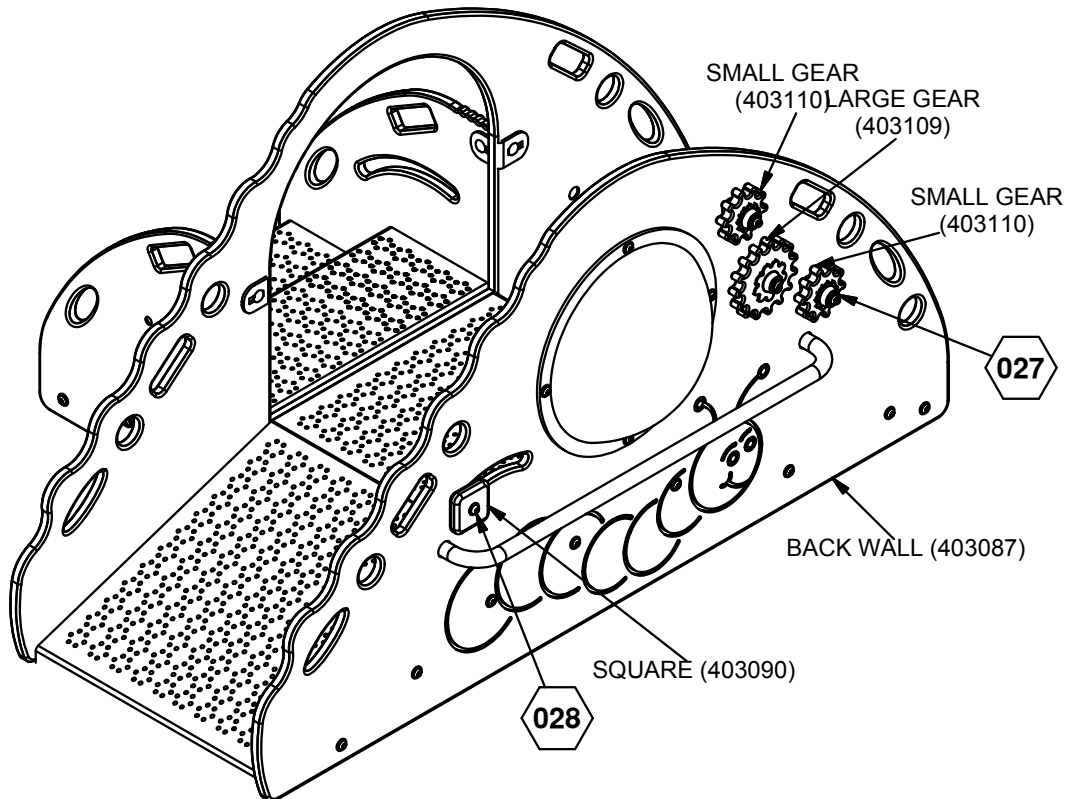
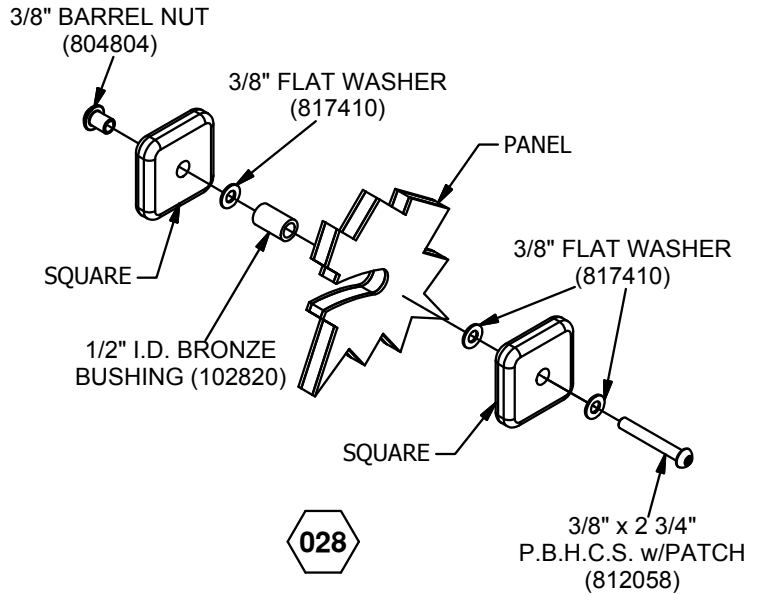
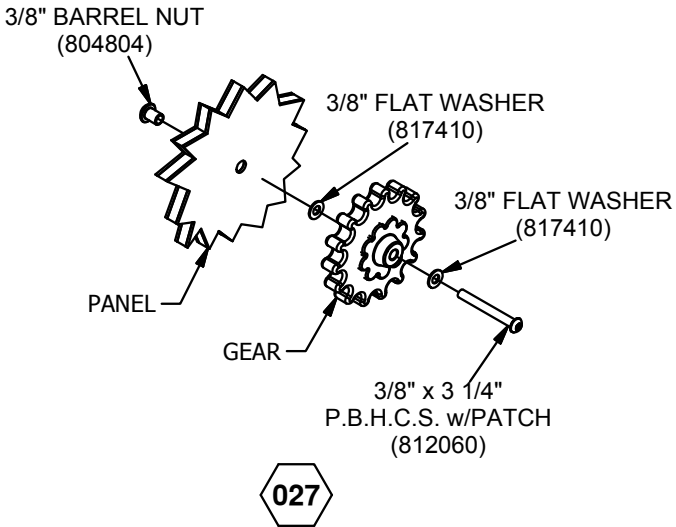

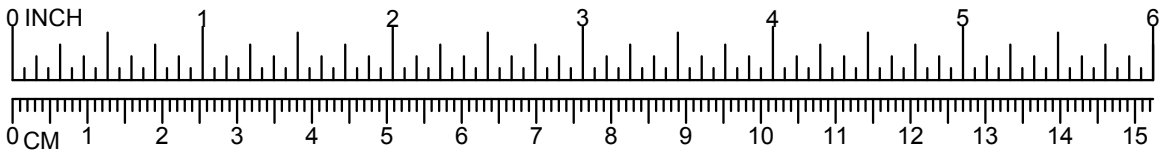

UP133 CRAWL & TODDLE (STANDARD) NATURAL STEP 7

1. Attach Spiral Wheel to Front Wall using 3/8" x 2 1/4" P.B.H.C.S. w/Patch, 3/8" Flat Washer, 1/2" I.D. Bronze Bushing, and 3/8" Barrel Nut. See Detail 029.
2. Attach Triangle to Left Side Wall using 3/8" x 2 3/4" P.B.H.C.S. w/Patch, 3/8" Flat Washer, 1/2" I.D. Bronze Bushing, and 3/8" Barrel Nut. See Detail 030.

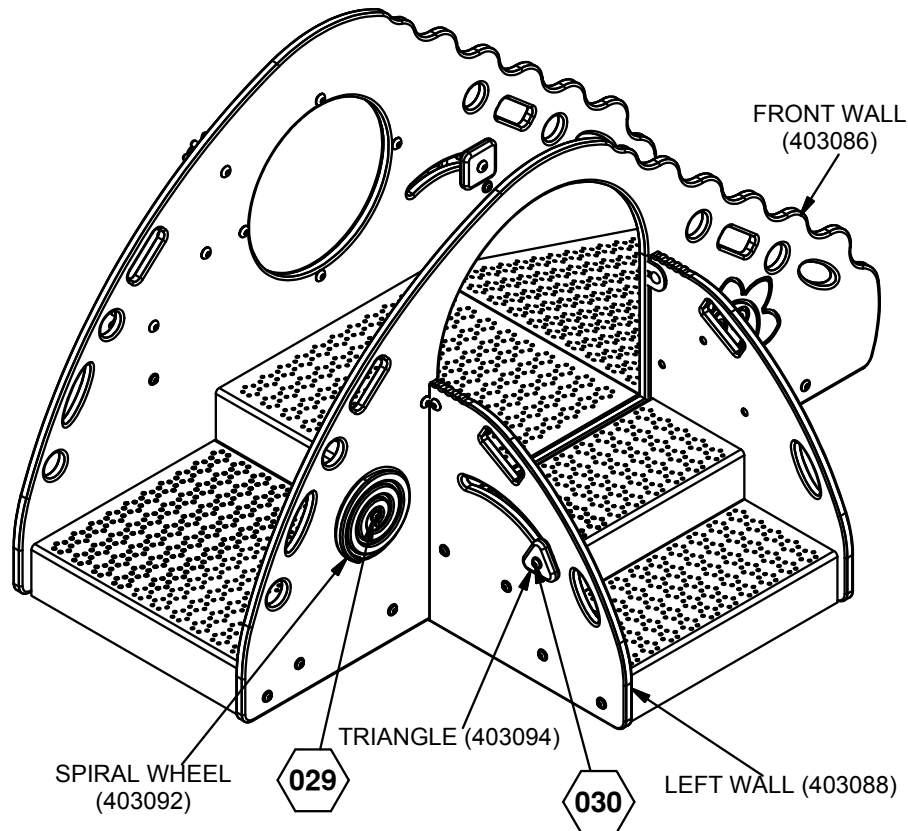
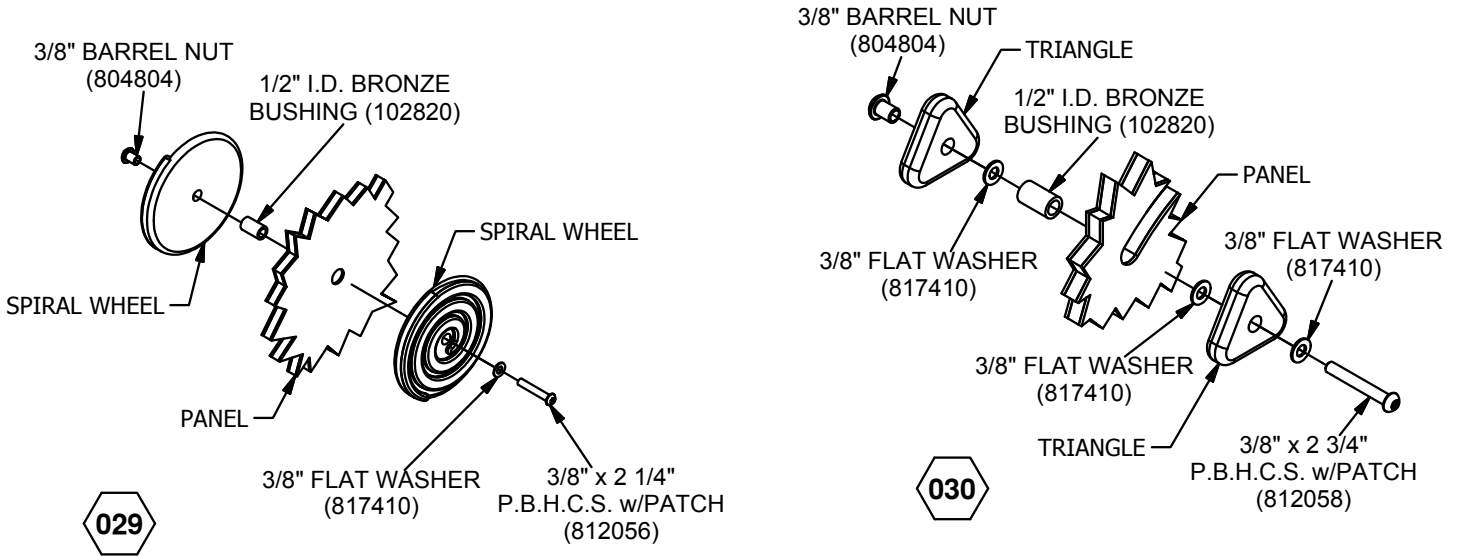

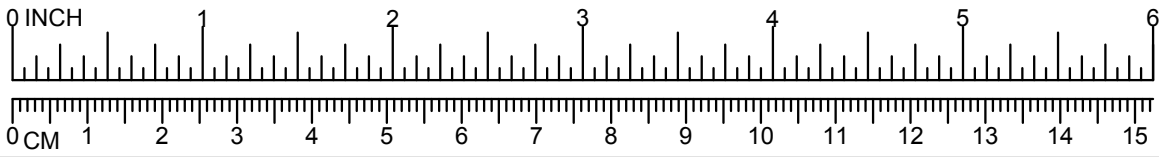

UP133 CRAWL & TODDLE (STANDARD) NATURAL STEP 8

1. Attach Circle Frame and Circle Mirror to Right Side Wall using 3/8" x 1 1/2" P.B.H.C.S. w/Patch, 3/8" Flat washer, and Barrel Nut. See Detail 031.
2. Plumb and level the entire assembly and tighten all fasteners.

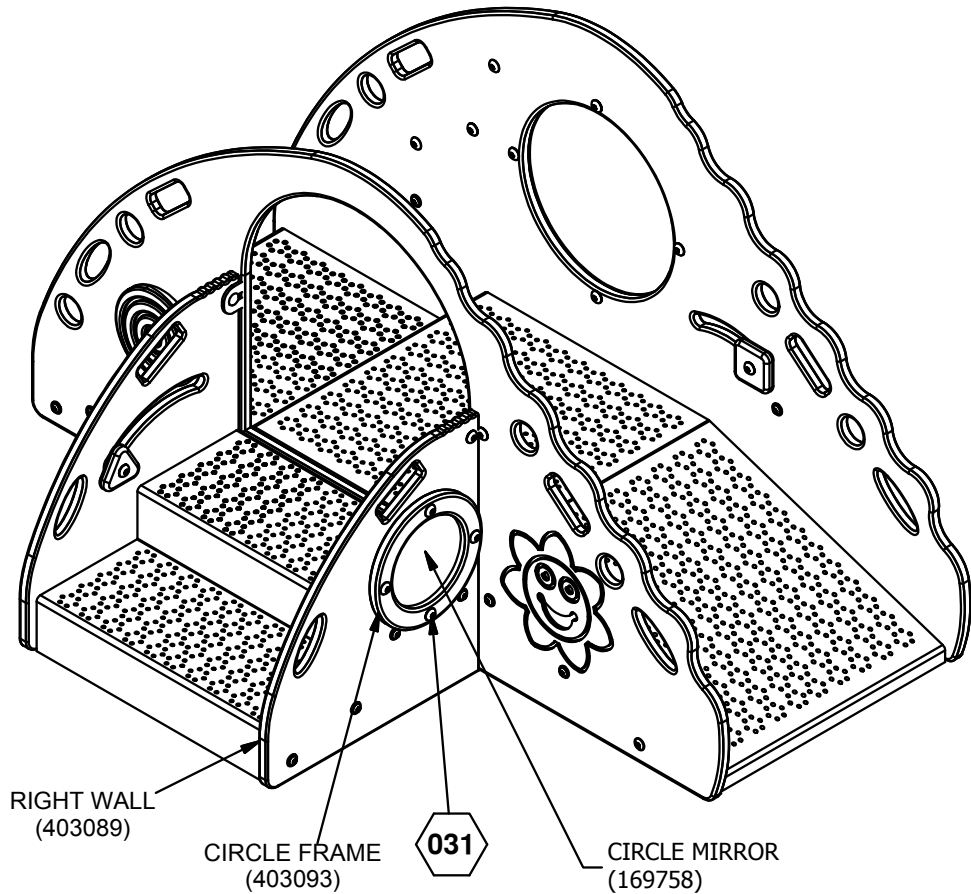
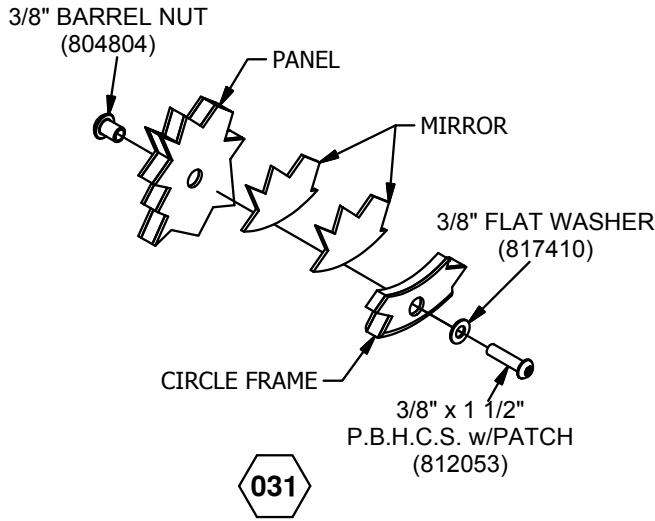

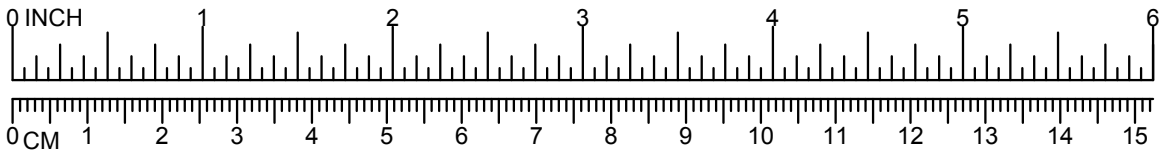

UP133 CRAWL & TODDLE (STANDARD) NATURAL STEP 9

1. Attach 6-23 Month Warning Label to Warning Label Plate. See Detail 045.
2. Attach Warning Label Plate to Back Wall using #4 x 1/2" Pan Head Screw. See Detail 045. Refer to view for location.

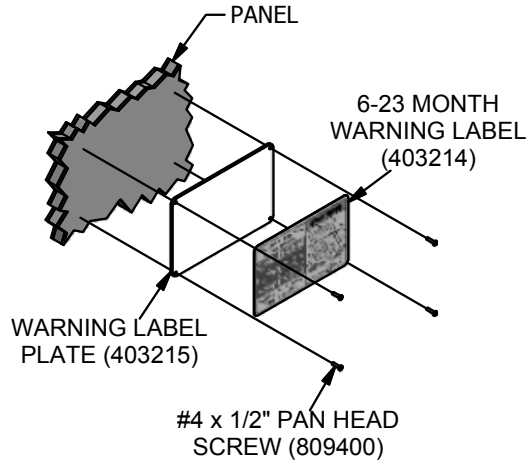

045

