

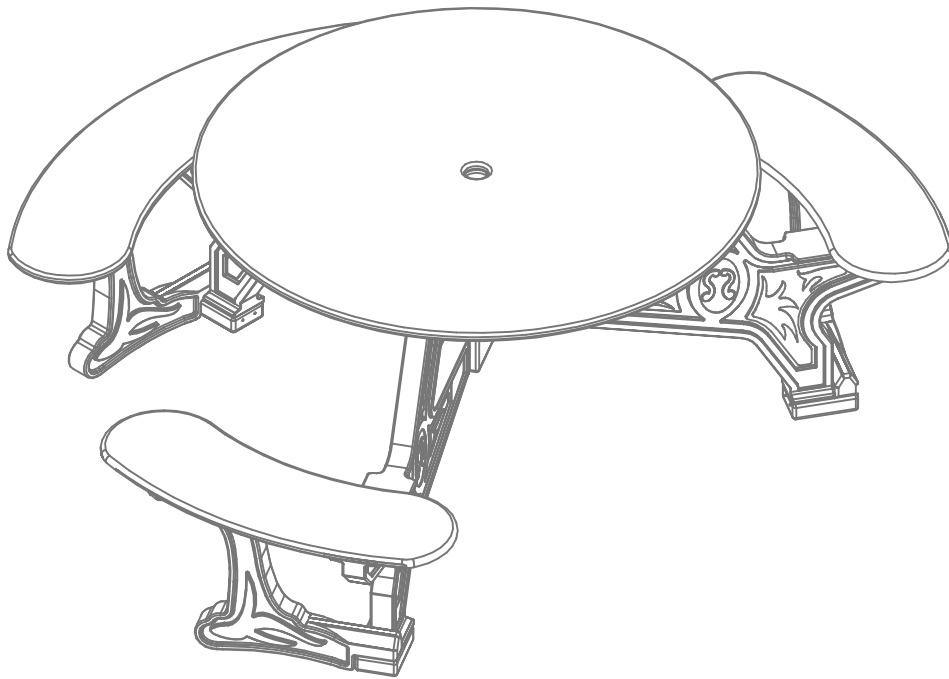

# Bodega Picnic Table



Before assembly, please make sure all components are included.

**J - Table Top**

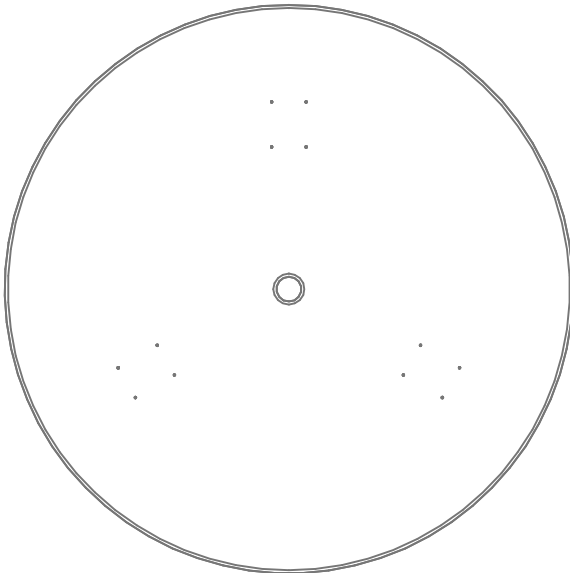

**(1) - One Table Top  
GSP-BOT-A-01**



**(1) - One Fastener Pack  
FP-BOTHA-CU-01**

**FP - Fastener Pack**

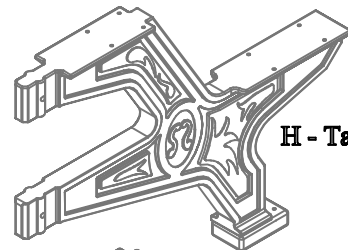

**H - Table Leg**

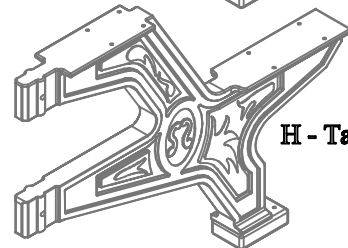

**H - Table Leg**

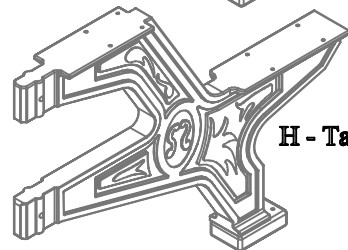

**H - Table Leg**

**(3) - Three Table Legs  
GSSA-PZ-C-01**

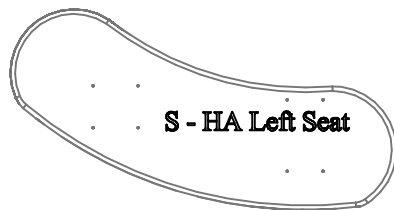

**S - HA Left Seat**

**(1) - One HA Left Seat  
GSP-BOTHA-A-01**

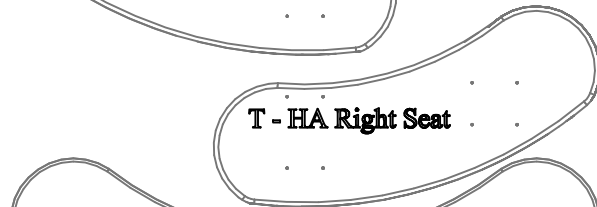

**T - HA Right Seat**

**(1) - One HA Right Seat  
GSP-BOTHA-B-01**

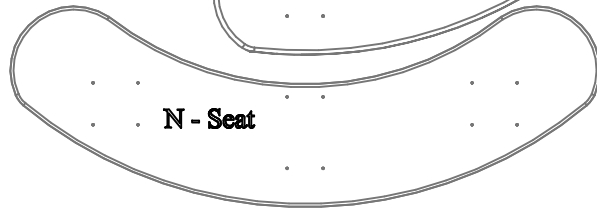

**N - Seat**

**(1) - One Seat  
GSP-BOT-B-01**

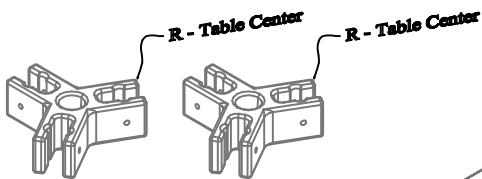

**R - Table Center**

**R - Table Center**

**(2) - Two Table Centers  
PS-GSCP-A-01**

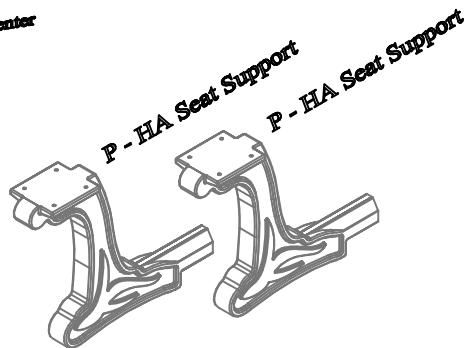

**P - HA Seat Support**

**P - HA Seat Support**

**(2) - Two HA Seat Supports  
PS-GSSS-B-01**

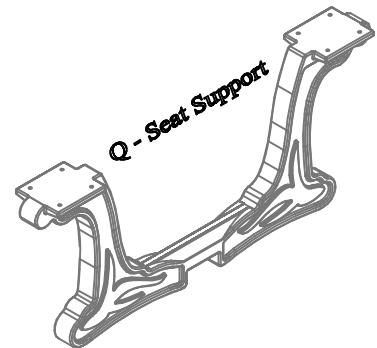

**Q - Seat Support**

**(1) - One Seat Support  
PS-GSSS-A-01**

Before assembly, please make sure all fasteners are included.

6 - 3/8" x 4 1/4" Hex Head Bolt

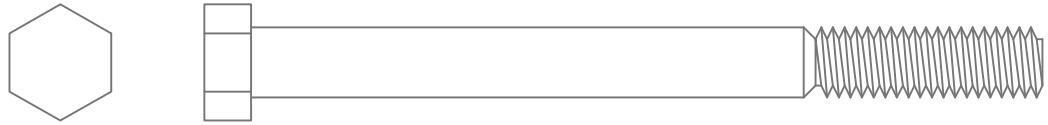

12 - 3/8" Flat Washer

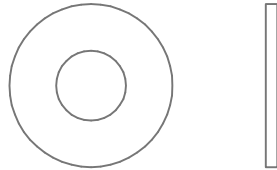

6 - 3/8" Nylon Lock Nut

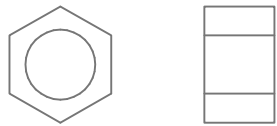

6 - #12 x 3" Flat Head Phillips Screw



16 - #12 x 1-1/4" Flat Head Phillips Screw



24 - #12 x 1" Pan Head Phillips Screw



Also needed for this assembly will be the following materials:

1 - #3 Phillips Drive Bit

2 - 9/16" Socket Wrench

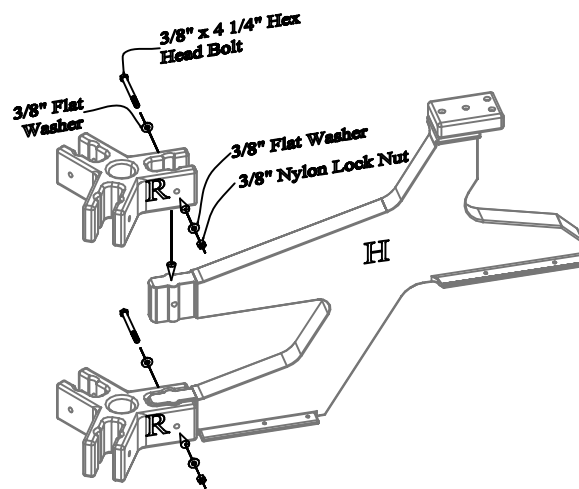

### Step #1:

Slide ( 1 ) One Table Center on to each end of the Table Leg as shown above. Use ( 1 ) One 3/8" x 4 1/4" Hex Head Bolt and ( 1 ) One 3/8" Flat Washer along with ( 1 ) One 3/8" Flat Washer and ( 1 ) One 3/8" Nylon Lock Nut per hole to secure.

Do not tighten bolts completely. This will be done in a later step.

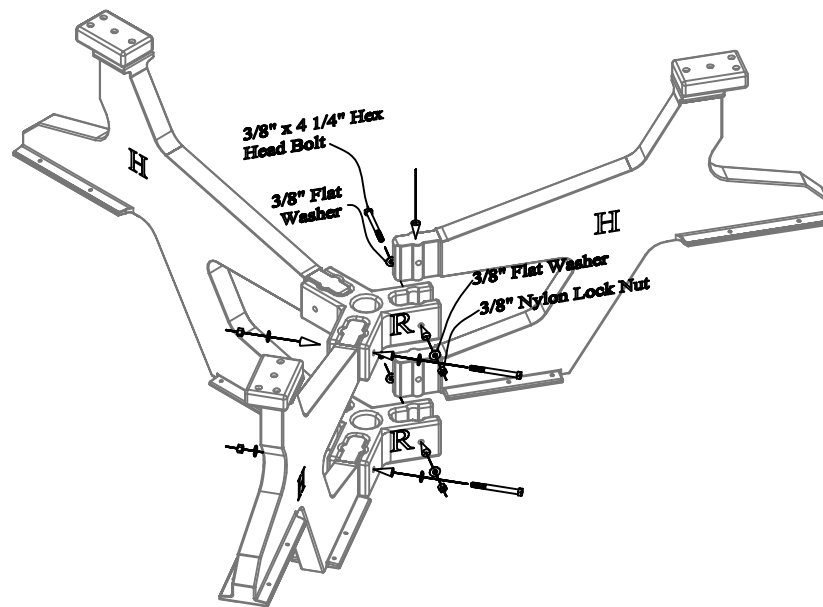

## Step #2:

Slide the remaining Table Legs in to the Table Centers. Use ( 1 ) One 3/8" x 4 1/4" Hex Head Bolt and ( 1 ) One 3/8" Flat Washer along with ( 1 ) One 3/8" Flat Washer and ( 1 ) One 3/8" Nylon Lock Nut per hole to secure.

Do not tighten bolts completely. This will be done in a later step.

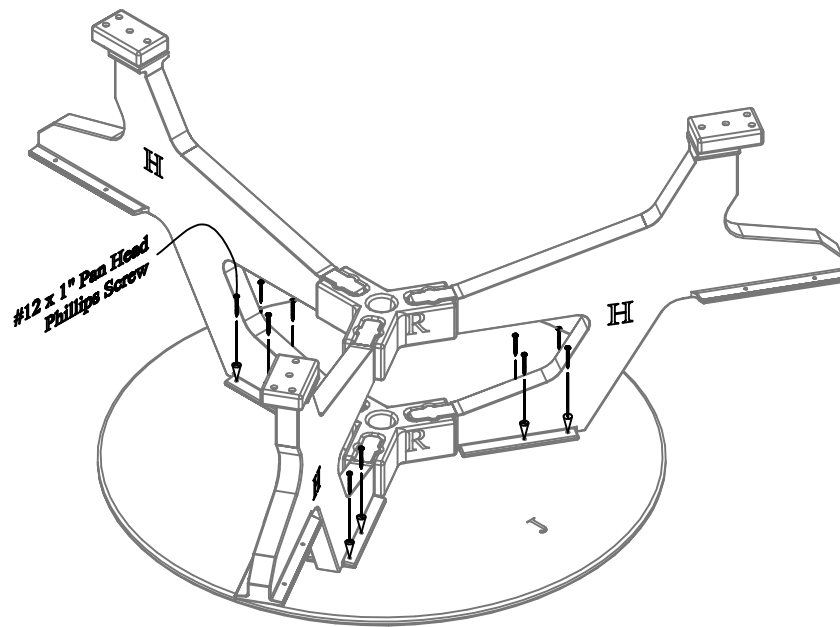

### Step #3:

While the Table Top is upside down, place the leg assembly onto the Table Top as shown above. Align the pre-drilled holes in the Table Legs with the pilot holes in the Table Top. Use ( 1 ) One #12 x 1" Pan Head Screw per hole to secure.

Be sure to tighten all screws after completing this step.

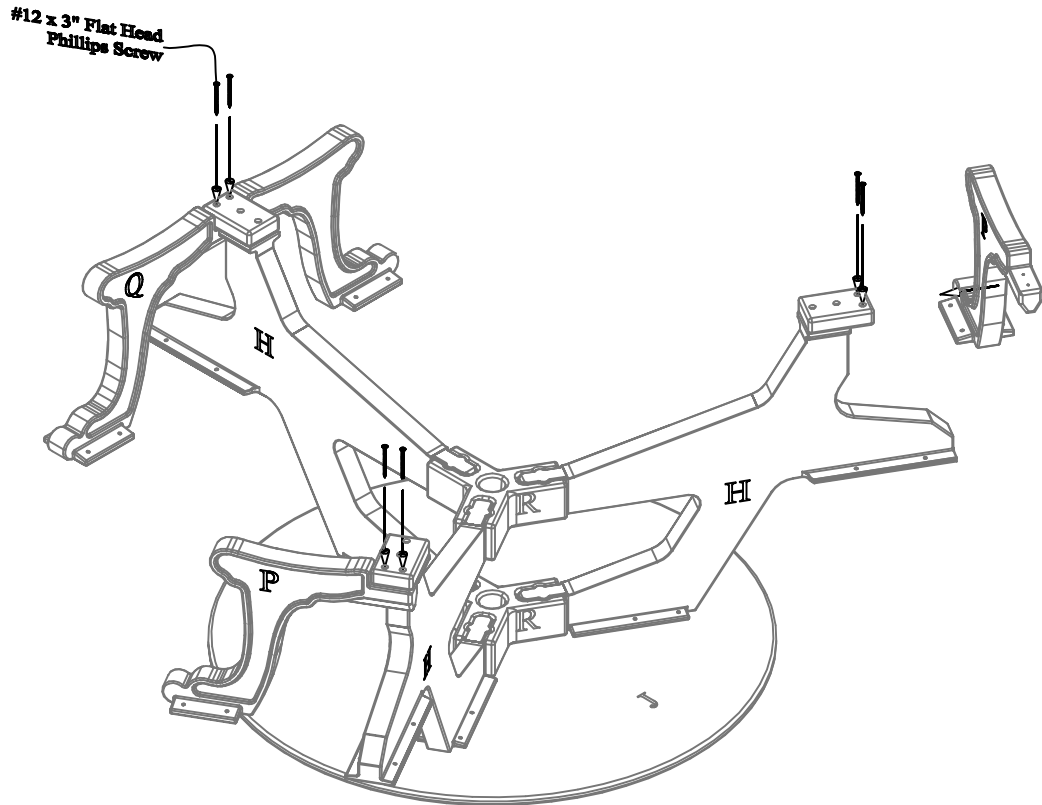

#### Step #4:

While the table is upside down, align the pre-drilled holes in the Table Leg to the pilot holes in the Seat Support as shown above. Use ( 1 ) One #12 x 3" Flat Head Screw per hole to secure.

Do not tighten screws completely. This will be done in a later step.

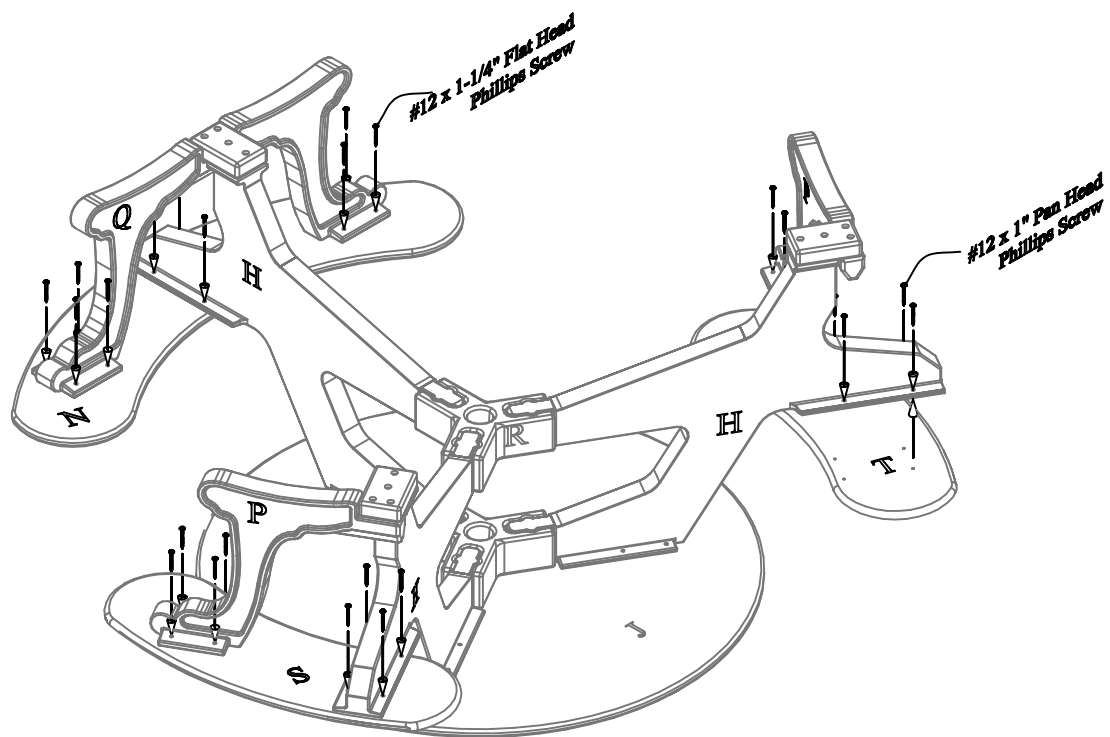

### Step #5:

While the table is upside down, align the pre-drilled holes in the Seat to the pilot holes in the Seat Support and the Table Leg as shown above. Use ( 1 ) One #12 x 1" Pan Head Screw per hole to secure the seat to the leg. Use ( 1 ) One #12 x 1-1/4" Flat Head Screw per hole to secure the seat to the seat support.

Be sure to tighten all loose screws after completing this step.



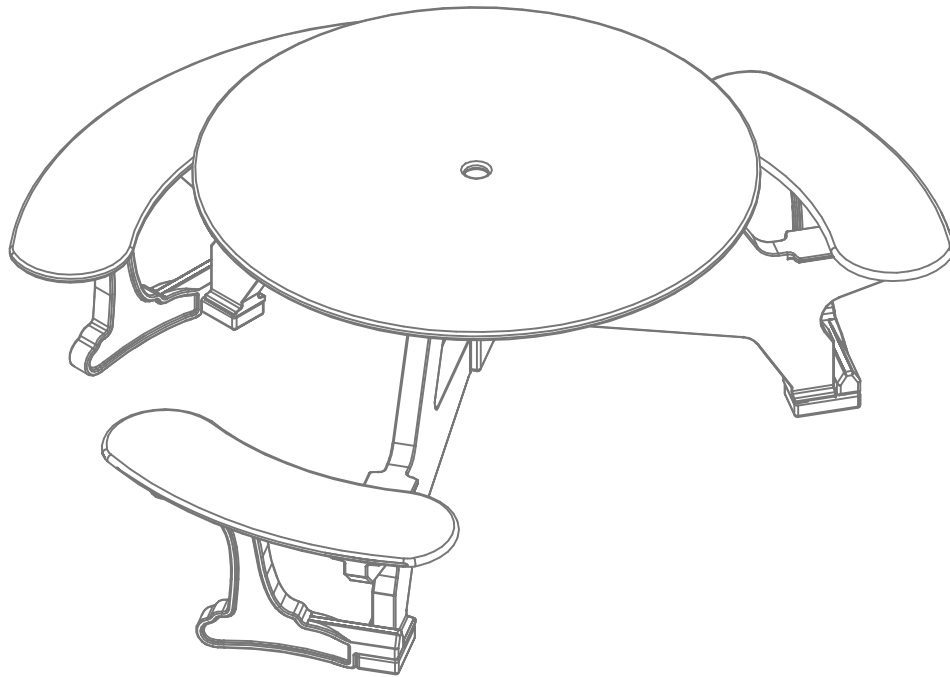

**Step #6:**

Turn the table over on to its legs, please use caution for the table weighs approximately 140 pounds.



DEAR VALUED CUSTOMER,

THANK YOU FOR PURCHASING THIS PRODUCT. THIS PRODUCT IS MANUFACTURED USING RECYCLED MATERIALS AND MAY HAVE SLIGHT COLOR VARIATIONS, OCCASIONAL SPECKS OF COLOR OR IRREGULAR SURFACE PATTERNS. THESE ARE NORMAL CONDITIONS OF RECYCLED PLASTICS AND MAKE EACH PIECE OF FURNITURE UNIQUE. THESE CHARACTERISTICS DO NOT AFFECT THE STRENGTH, QUALITY OR PERFORMANCE OF THE PRODUCT.

THANK YOU AGAIN FOR PURCHASING THIS PRODUCT AND HELPING OUR ENVIRONMENT.