

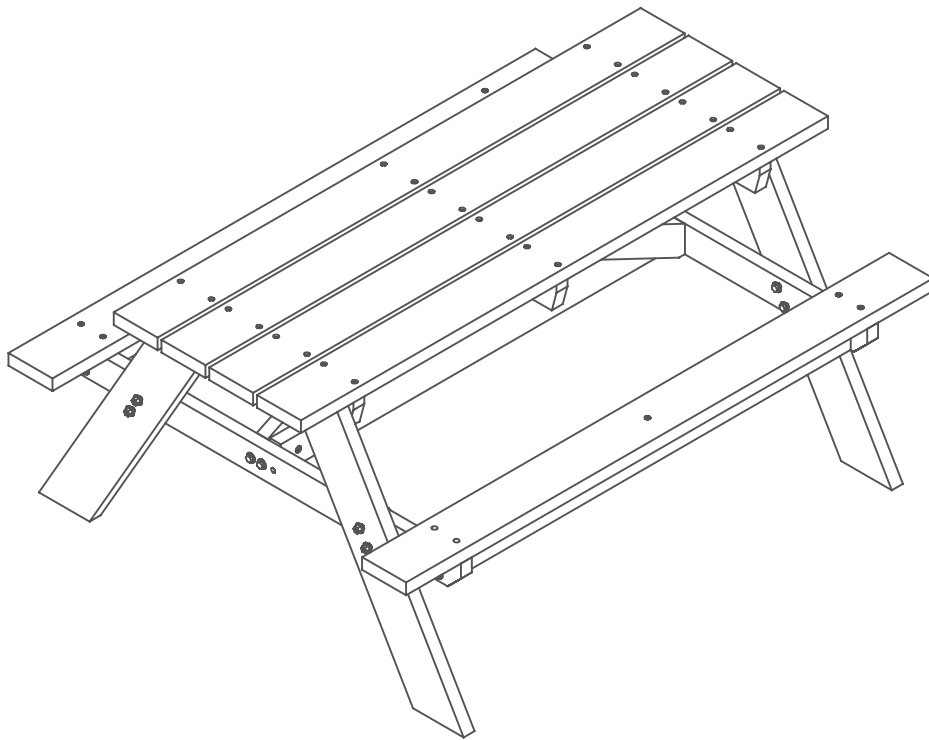

5ft - Economizer Children's Picnic Table

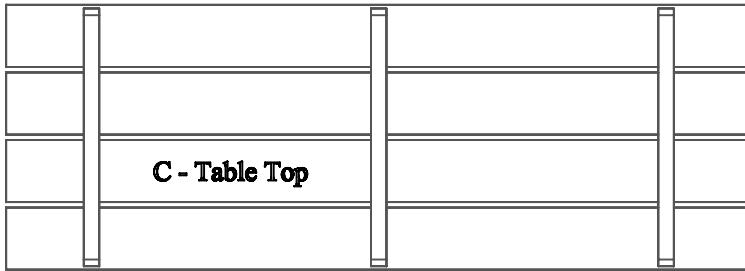

Before assembly, please check to make sure all components are included.



(1) - One Table Top
STSA-EPTY-A-00

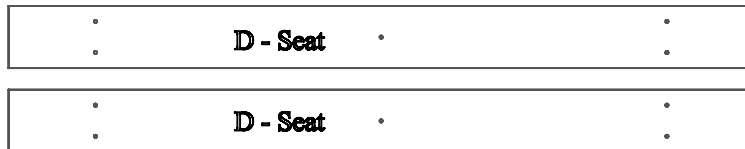

(2) - Two Seats
STP-LWK5-B-00

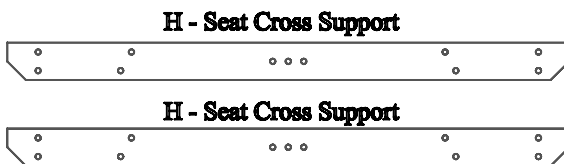

(2) - Two Seat Cross Supports
STP-LWK5-G-01

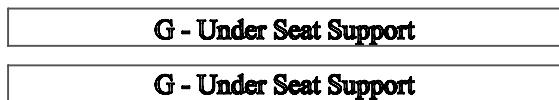

(2) - Two Under Seat Supports
STP-LWK5-H-00



(2) - Two Angle Supports
STP-LWK5-E-00



(4) - Four Universal Legs
STP-LWK5-F-00



(2) - One Center Support
STP-LWK5-I-00

FP - Fastener Pack

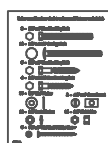

(1) - One Fastener Pack
FP-EPTY-CU-01

Before assembly, please check to make sure all fasteners are included.

16 - 3/8" x 3 1/4" Hex Head Bolt

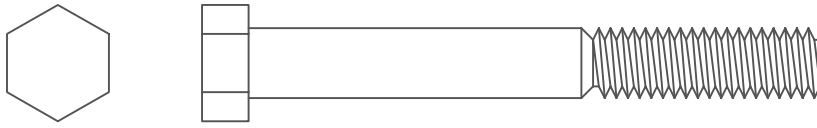

2 - 3/8" x 4" Hex Head Tap Bolt

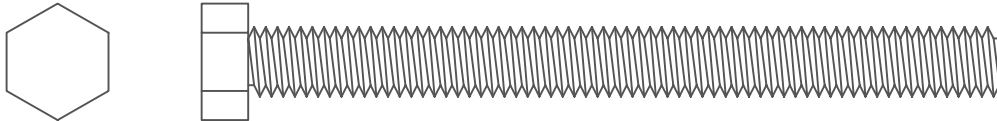

8 - 3/8" x 3" Hex Head Lag Bolt

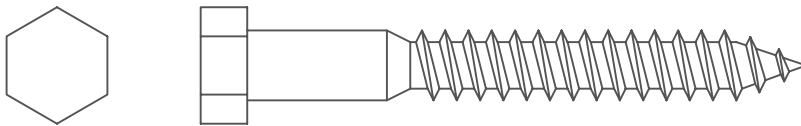

4 - 3/8" x 2 1/2" Hex Head Lag Bolt

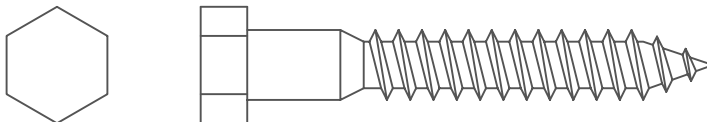

46 - 3/8" Flat Washer

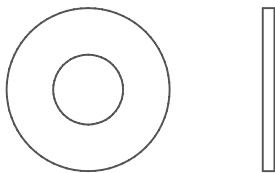

2 - 5/8" x 1" Cross Dowel

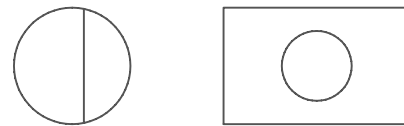

16 - 3/8" Nylon Lock Nut

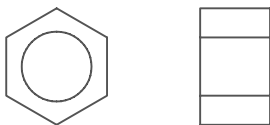

10 - #12 x 2-1/2" Flat Head Phillips Screw



Also needed for this assembly will be the following materials:

2 - 9/16" Socket Bit

1 - 1/4" Flat Head Screwdriver

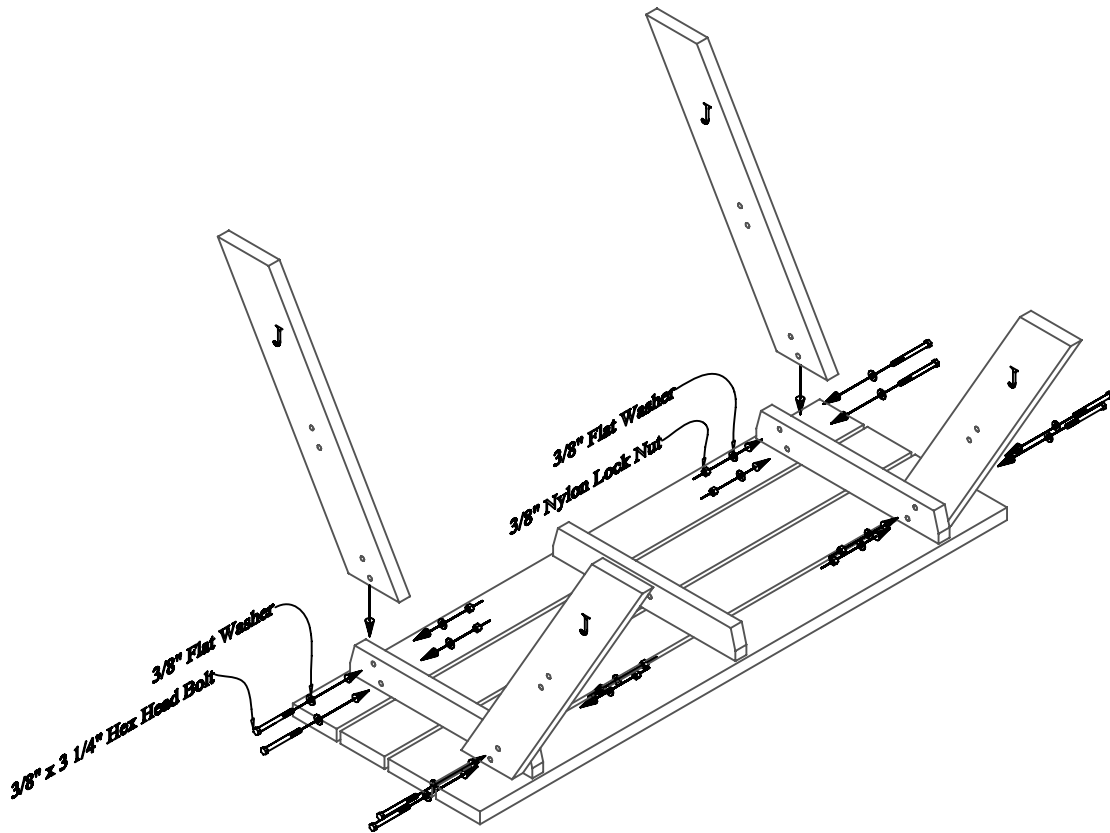

Step #1:

While the table top is upside-down, fasten the legs to the under top supports being sure that the legs are on the outside of the under top supports as shown above. Use (1) One 3/8" x 3 1/4" Hex Head Bolt along with (1) One 3/8" Flat Washer and (1) one 3/8" Flat washer along with (1) one Nylon Lock Nut per hole to secure.

Note: Do not tighten bolts completely. This will be done in a later step.

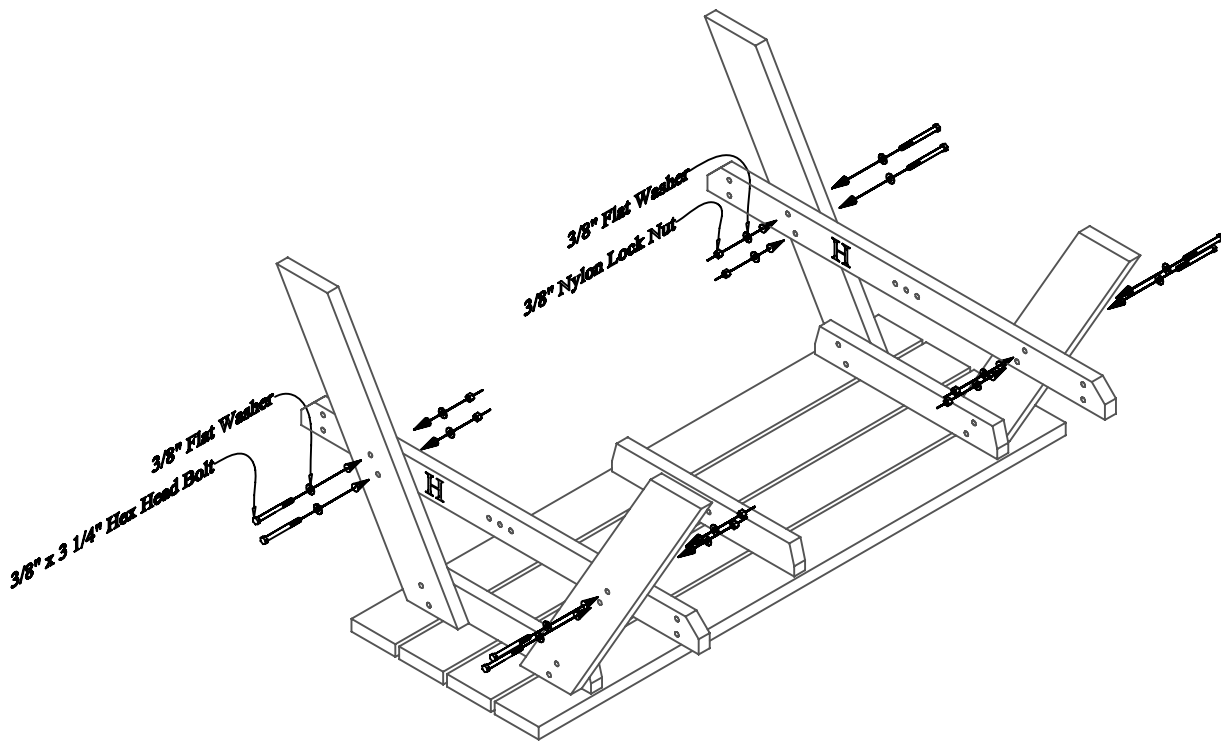

Step #2:

While the table top is upside-down, fasten the seat cross supports to the legs. Use (1) One 3/8" x 3 1/4" Hex Head Bolt along with (1) One 3/8" Flat Washer and (1) One 3/8" Flat Washer along with (1) One 3/8 Nylon Lock Nut per hole to secure.

Note: Do not tighten bolts completely. This will be done in a later step.

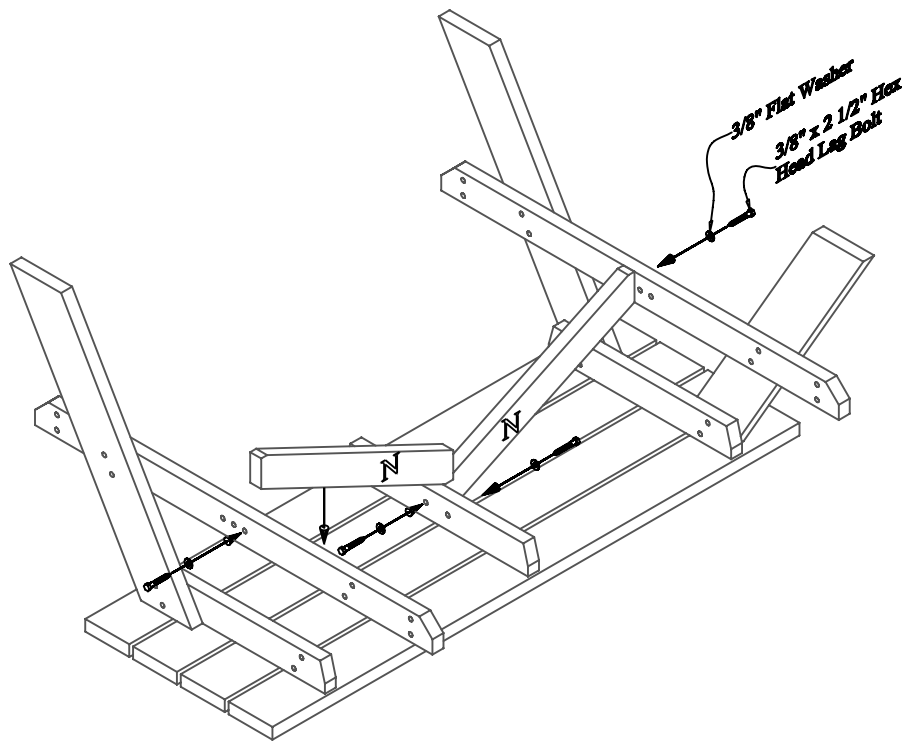

Note:
Leg is removed to show detail.
Do not remove for this step.

Step #3:

While the table top is upside-down, fasten the angle supports to the seat cross supports and the center top support. Use (1) One 3/8" x 2 1/2" Hex Head Lag Bolt and (1) One 3/8" Flat Washer per hole to secure.

Note: Be sure to tighten all loose bolts after this step is complete.

Step #4:

Place (1) One $5/8''$ x $1''$ Cross Dowel in each hole of the Center Support as shown in the diagram below. You may need to tap the Cross Dowels in place. Be sure the score on the dowel head is in line with the length of the Center Support as shown below.

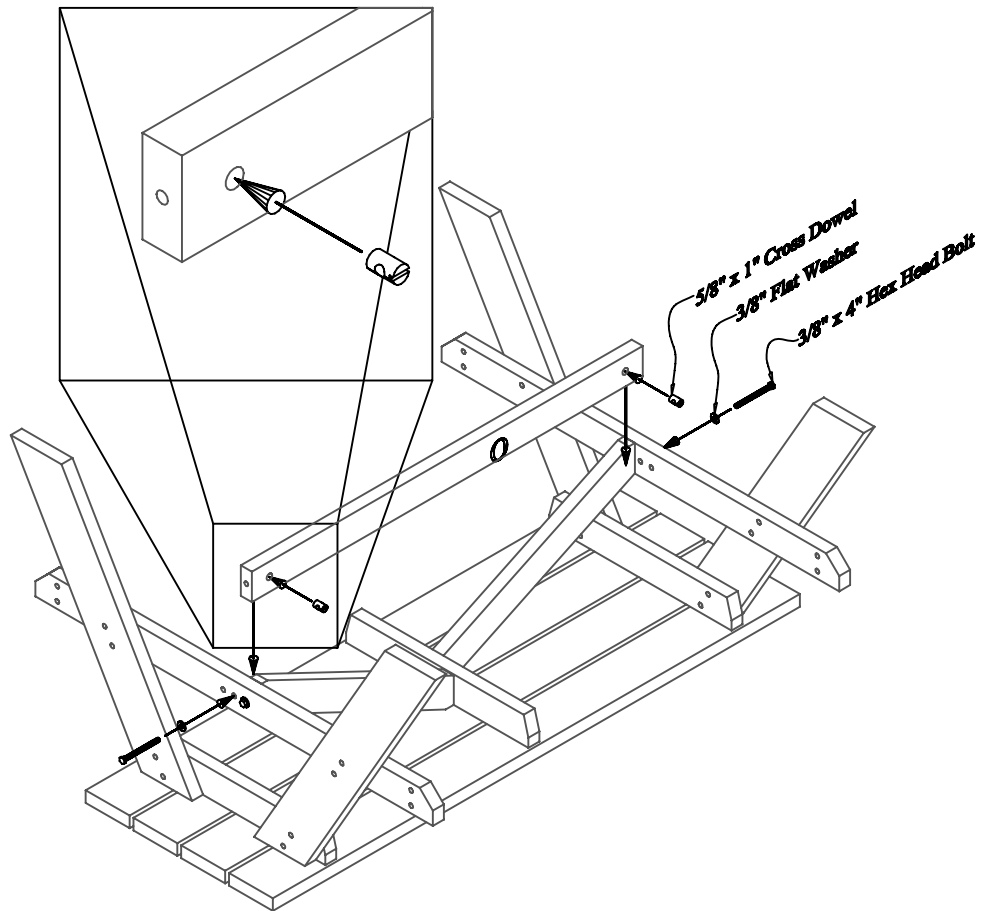

Step #5:

While the table top is upside-down, fasten the center support to the seat cross supports. Use (1) One $3/8''$ x $4''$ Hex Head Tap Bolt and (1) One $3/8''$ Flat Washer per hole to secure.

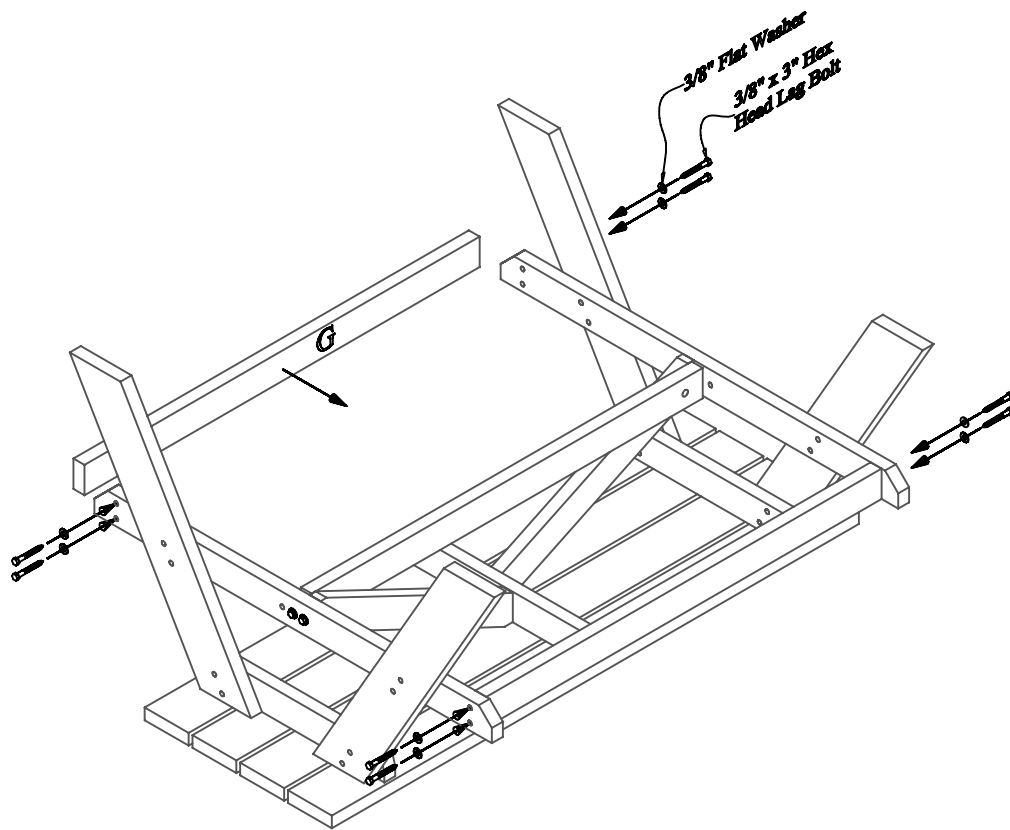

Step #6:

While the table top is upside-down, fasten the under seat supports to the seat cross supports. Use (1) One 3/8" x 3" Hex Head Lag Bolt and (1) One 3 /8" Flat Washer per hole to secure.

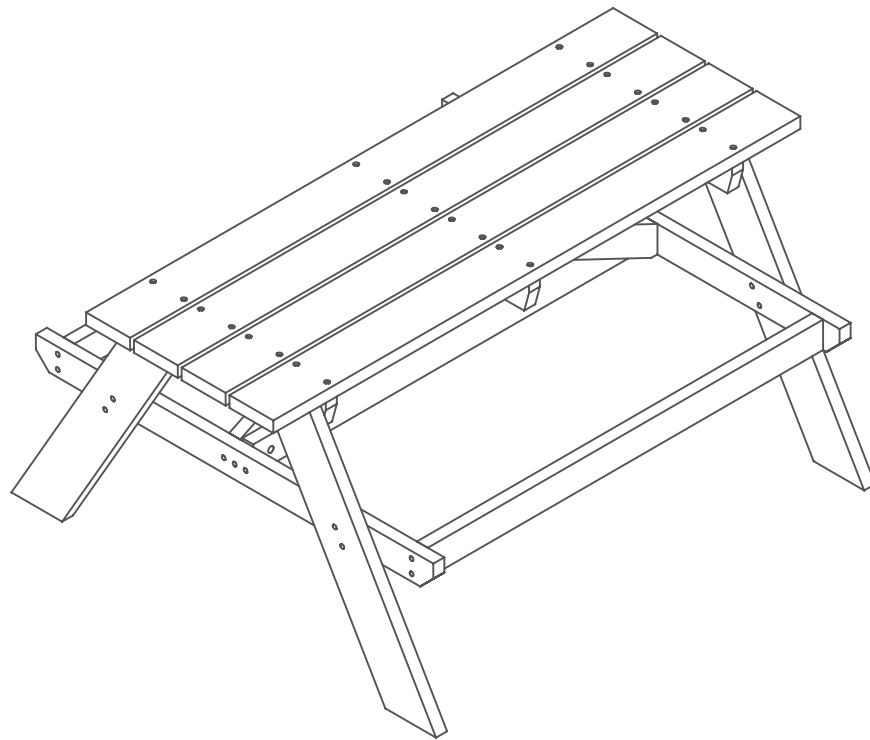

Step #7:

Flip the table upright onto the legs. Please take caution while flipping the table. At this point in assembly the table weighs approximately 100 Pounds.

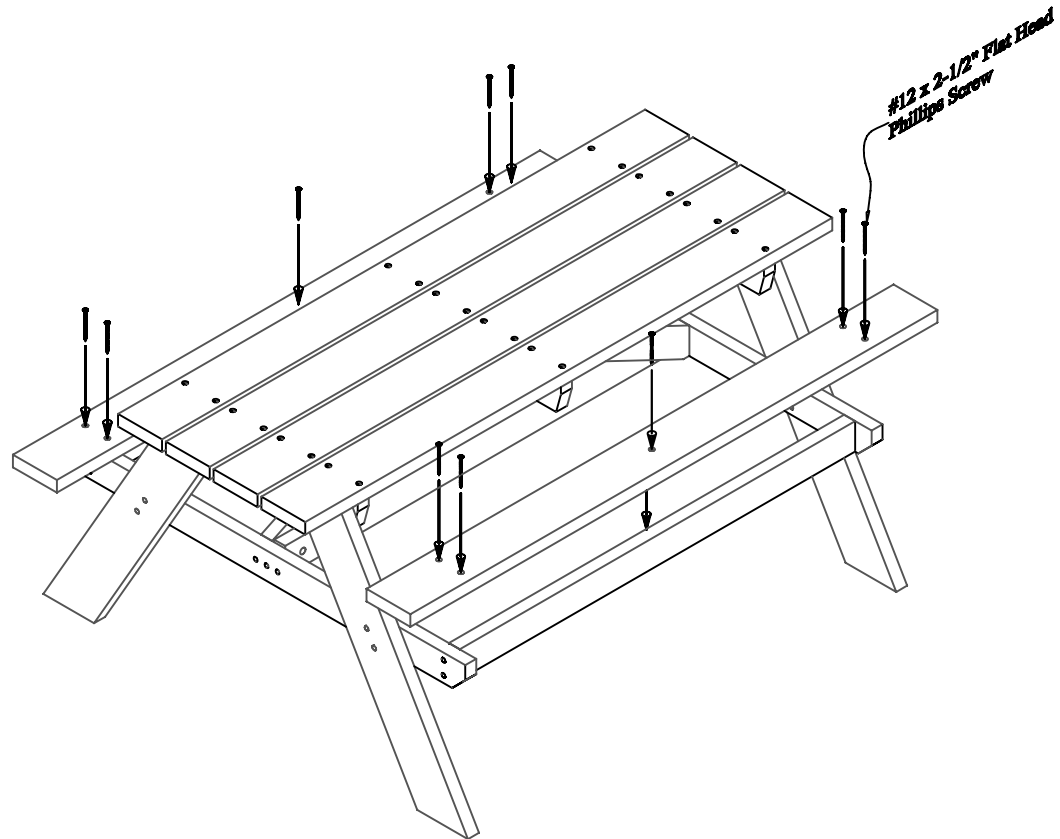

Step #8:

While the table is upright fasten the seats to the seat cross supports and the under seat supports being sure to center it over the under seat support. Use (1) One #12 x 2-1/2" Flat Head Phillips Screw per hole to secure.