

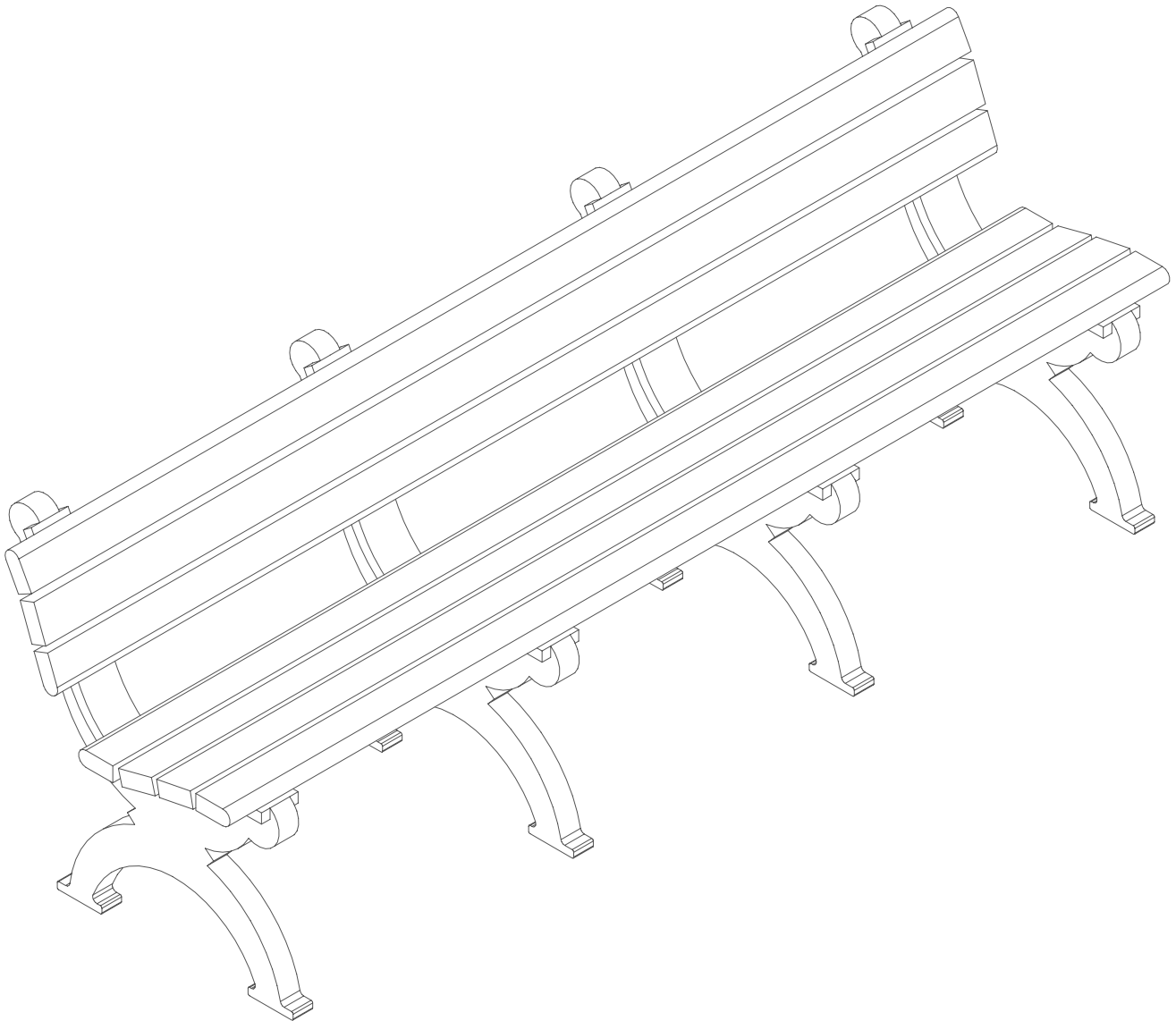

Silhouette Bench - With Back - 8FT



Before assembly, please make sure all components are included.



(1) - One Fastener Pack
FP-SB8B-CU-01

FP - Fastener Pack

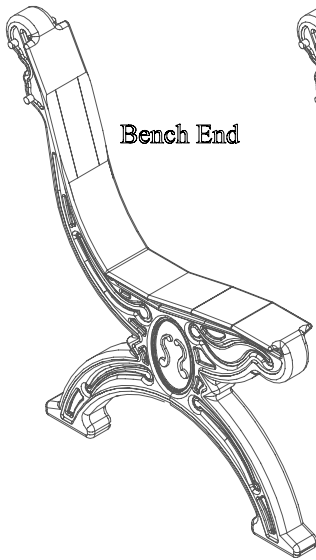

Bench End

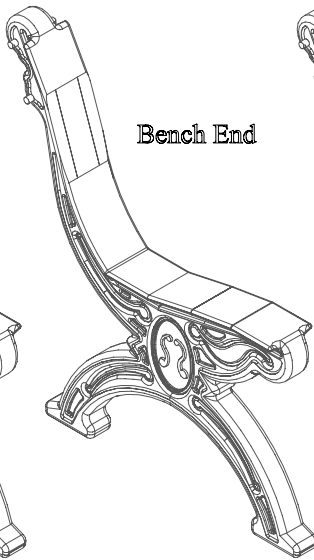

Bench End

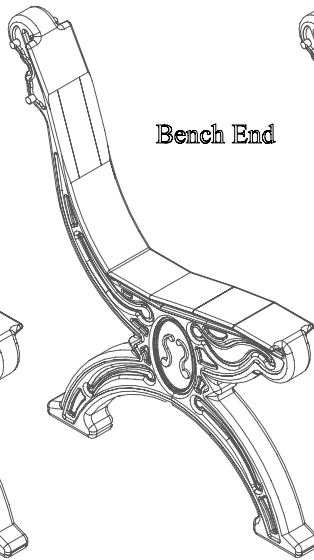

Bench End

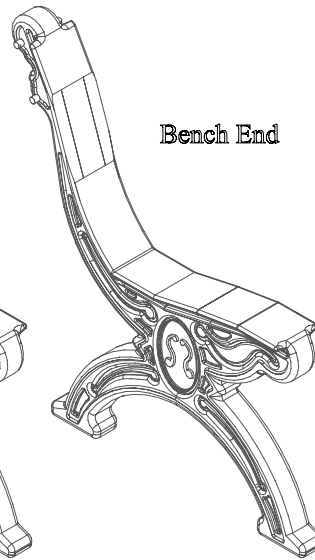

Bench End

(4) - Four Bench Ends
PS-CBBE-B-01

• •	• •	• •	• •
• •	• •	• •	• •
• •	• •	• •	• •

(3) - Three Bench Boards
BP-MB8B-A-01

• •	• •	• •	• •
• •	• •	• •	• •
• •	• •	• •	• •
• •	• •	• •	• •

(4) - Four Bull-nosed Bench Boards
BP-SB8B-A-01

Before assembly, please make sure all fasteners are included.

56 - #12 x 1 1/2" Pan Head Phillips Screw

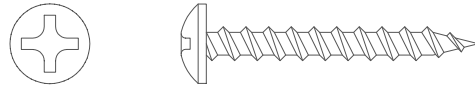

Also needed for this assembly will be the following materials:

1 - #3 Phillips Drive Bit

Fig #1:

In order to make the assembly of this Silhouette Bench easier while going through the assembly process the board positions are numbered and will be referenced in later steps.

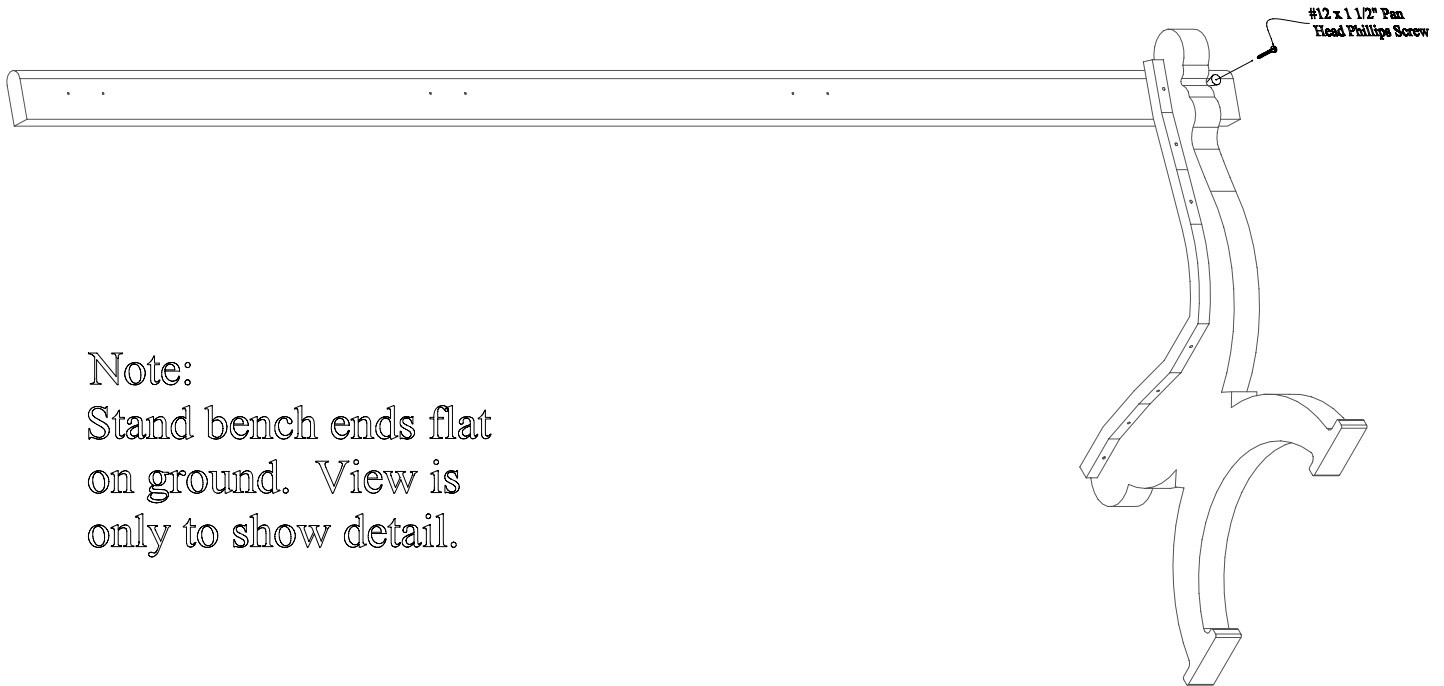
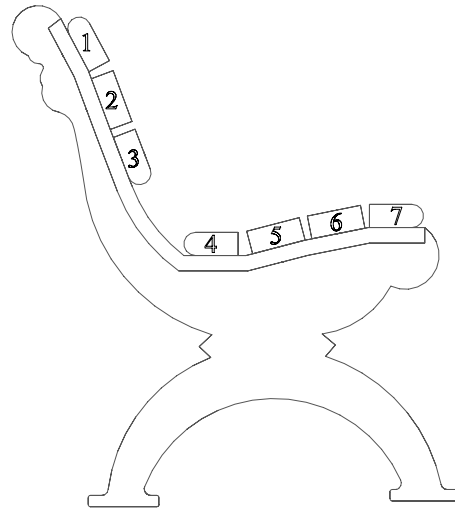

Note:

Stand bench ends flat on ground. View is only to show detail.

Step #1:

Stand (1) One bench end upright and place (1) One bull-nosed bench board (B) on position 1 being sure to align the pilot holes to the pre-drilled holes in the bench end. After the holes are properly aligned, fasten with (1) One #12 x 1 1/2" Pan Head Phillips Screw in the pre-drilled hole on the right side of the bench end.

Note: Do not tighten screw completely. This will be done in a later step.

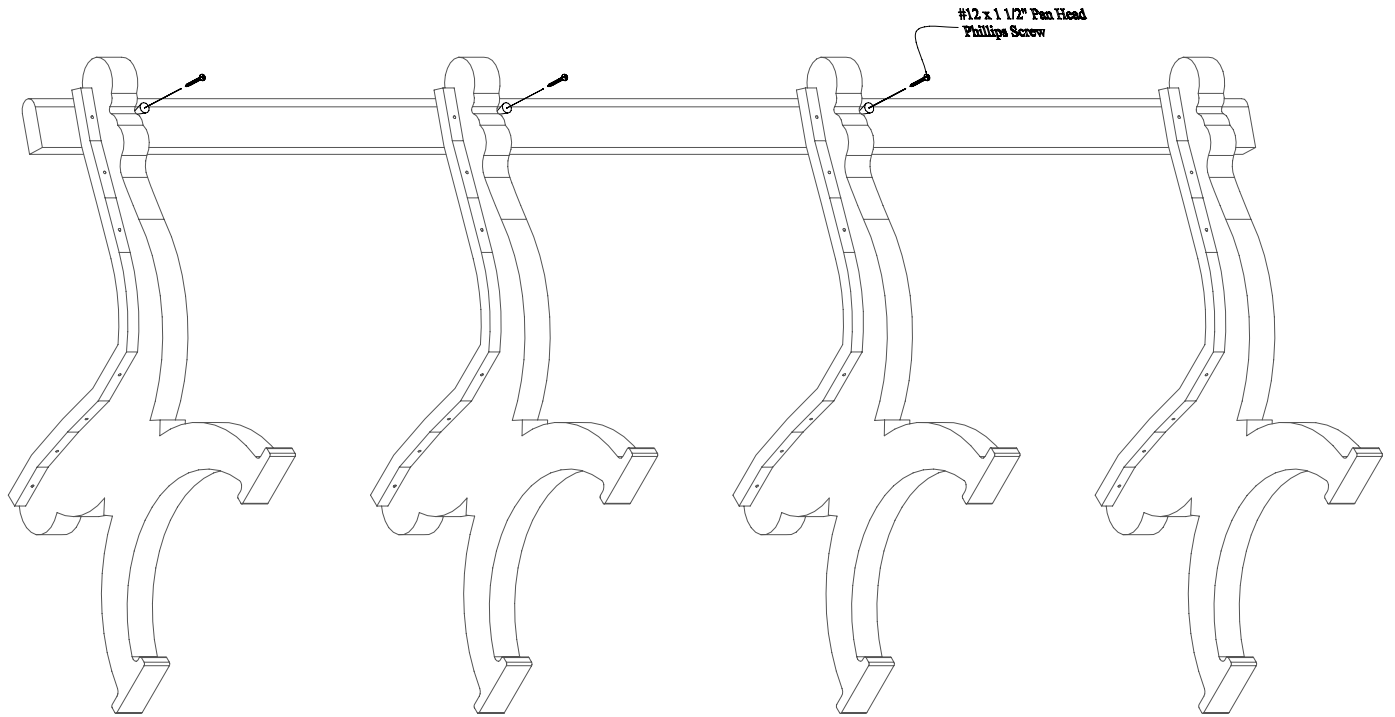

Step #2:

Stand the other (3) Three bench ends upright, one at a time, and place the bull-nosed bench board (B) already attached to the first bench end, on position 1 being sure to align the pilot holes with the pre-drilled holes in the bench end. After the holes are properly aligned, fasten with (1) One #12 x 1 1/2" Pan Head Phillips Screw in the pre-drilled hole on the right side of the bench end.

Note: Do not tighten screws completely. This will be done in a later step.

Step #3:

Align the pilot holes on the bull-nosed bench board (B) to the pre-drilled holes on the left side of the bench ends. After the holes are properly aligned, fasten with (1) One #12 x 1 1/2" Pan Head Phillips Screw per bench end.

Note: Be sure to tighten screws completely after this step.

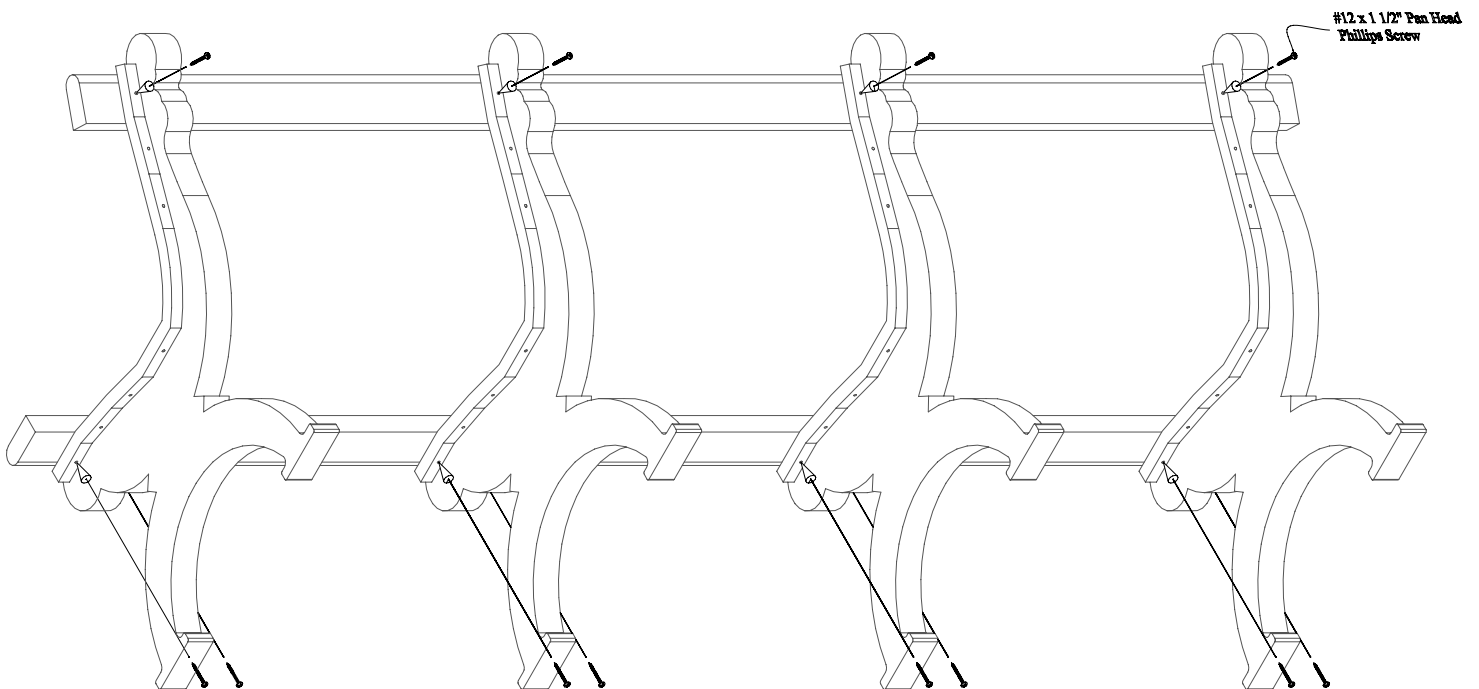

Step #4:

Place a second bull-nosed bench board (B) on position 7. Repeat Steps 1 - 3 to attach. Use (1) One #12 x 1 1/2" Pan Head Phillips Screw per hole to fasten.

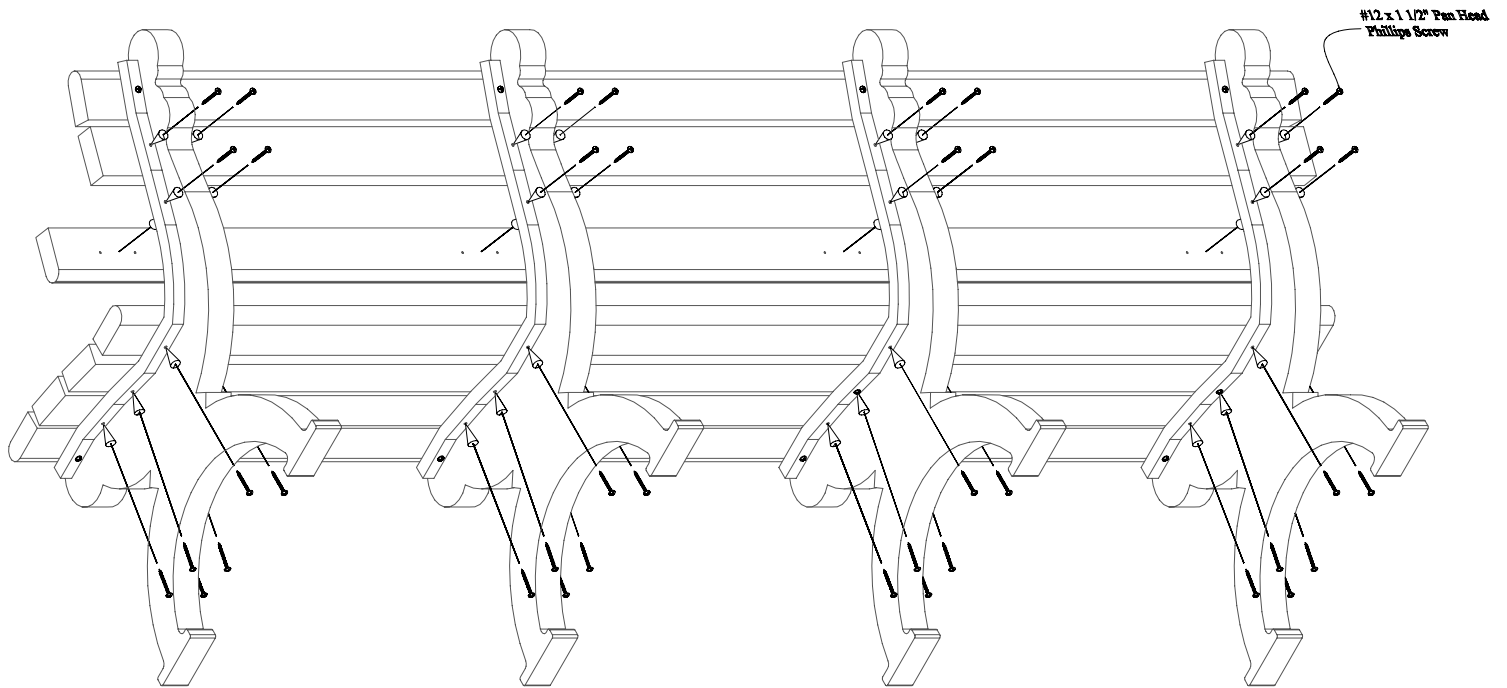

Step #5:

Repeat Steps 1 - 3 to attach bench boards (A) on positions 2, 5 & 6 and bull-nosed bench boards (B) on positions 3 & 4. Use (1) One #12 x 1 1/2" Pan Head Phillips Screw per hole to fasten.

DEAR VALUED CUSTOMER,

THANK YOU FOR PURCHASING THIS PRODUCT. THIS PRODUCT IS MANUFACTURED USING RECYCLED MATERIALS AND MAY HAVE SLIGHT COLOR VARIATIONS, OCCASIONAL SPECKS OF COLOR OR IRREGULAR SURFACE PATTERNS. THESE ARE NORMAL CONDITIONS OF RECYCLED PLASTICS AND MAKE EACH PIECE OF FURNITURE UNIQUE. THESE CHARACTERISTICS DO NOT AFFECT THE STRENGTH, QUALITY OR PERFORMANCE OF THE PRODUCT.

THANK YOU AGAIN FOR PURCHASING THIS PRODUCT AND HELPING OUR ENVIRONMENT.