

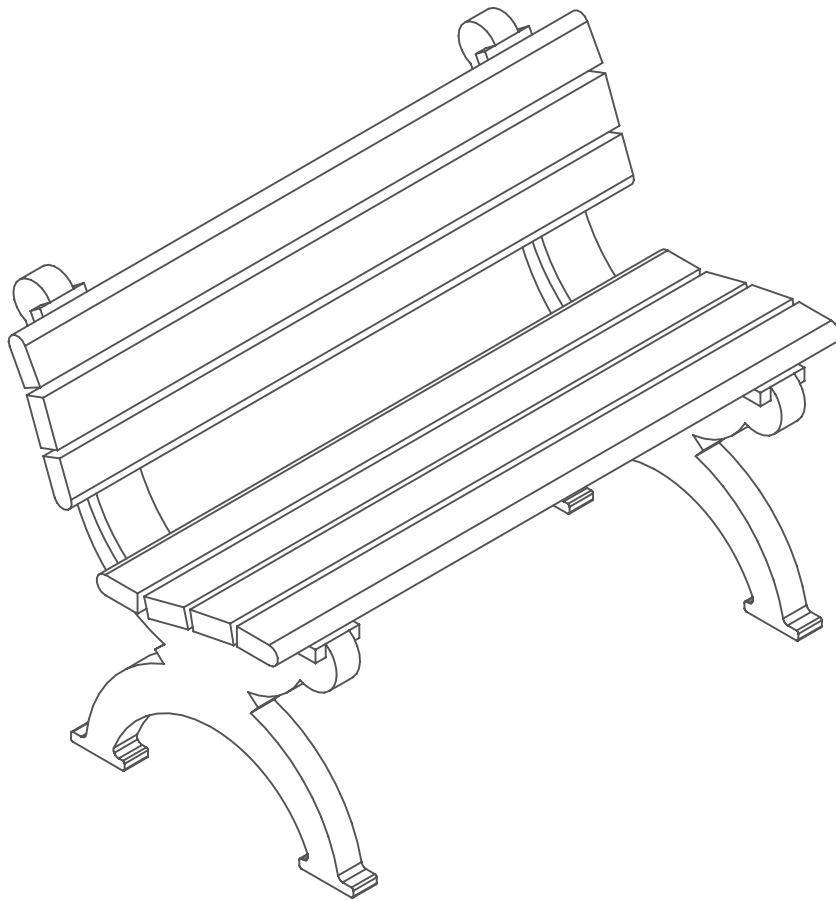

Silhouette Bench - With Back - 4FT



assembly, please make sure all components are included.



(1) - One Fastener Pack
FP-SB4B-CU-01

FP - Fastener Pack

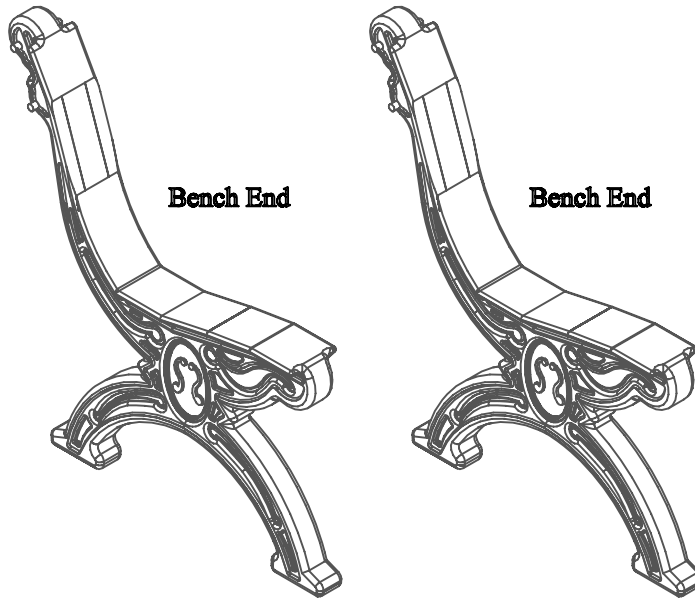

(2) - Two Bench Ends
PS-CBBE-B-01

• •	A - Bench Board	• •
• •	A - Bench Board	• •
• •	A - Bench Board	• •

(3) - Three Bench Boards
BP-MB4B-A-01

• •	B - Bull-nosed Bench Board	• •
• •	B - Bull-nosed Bench Board	• •
• •	B - Bull-nosed Bench Board	• •
• •	B - Bull-nosed Bench Board	• •

(4) - Four Bull-nosed Bench Boards
BP-SB4B-A-01

c assembly, please make sure all fasteners are included.

28 - #12 x 1 1/2" Pan Head Phillips Screw



Also needed for this assembly will be the following materials:

1 - #3 Phillips Drive Bit

Fi:

In order to make the assembly of this Silhouette Bench easier while going through the assembly process the board positions are numbered and will be referenced in later steps.

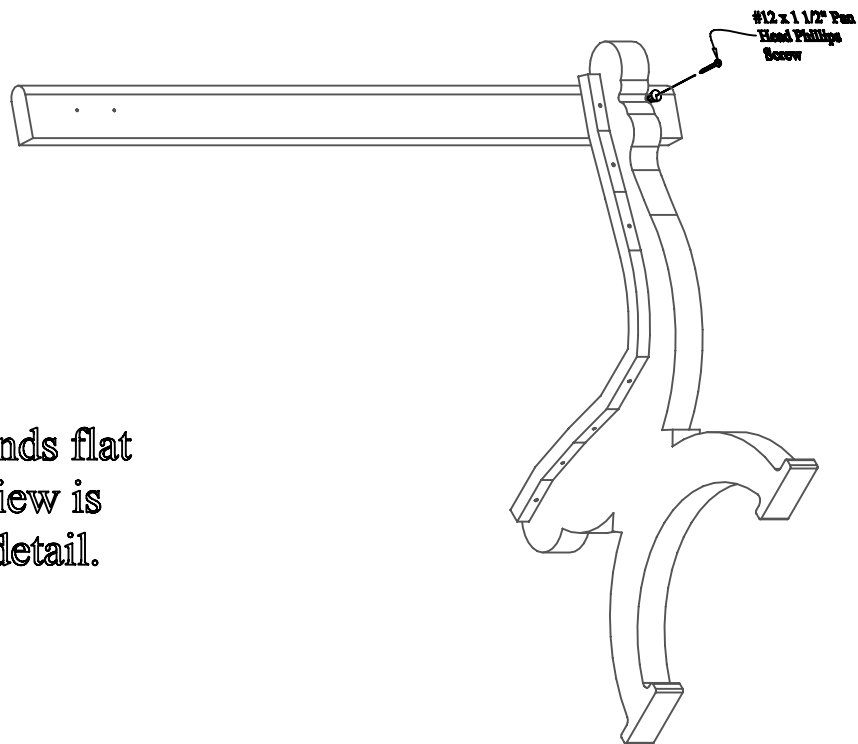
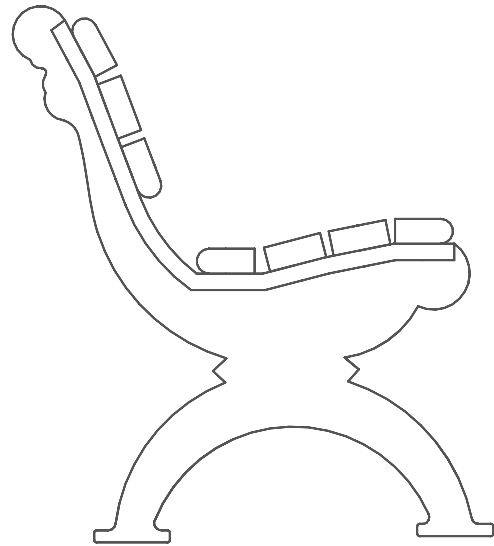

Note:

Stand bench ends flat on ground. View is only to show detail.

Step #1:

Stand (1) One bench end upright and place (1) One bull-nosed bench board (B) on position 1 being sure to align the pilot holes to the pre-drilled holes in the bench end. After the holes are properly aligned, fasten with (1) One #12 x 1 1/2" Pan Head Phillips Screw in the pre-drilled hole on the right side of the bench end.

Note: Do not tighten screw completely. This will be done in a later step.

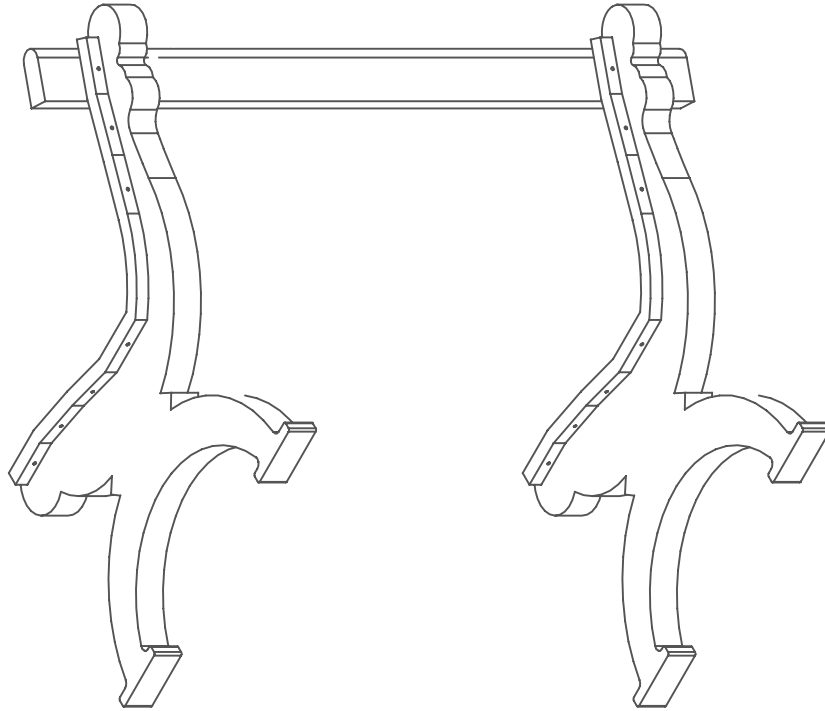

Step #2:

Stand the other bench end upright, and place the bull-nosed bench board (B) already attached to the first bench end, on position 1 being sure to align the pilot holes with the pre-drilled holes in the bench end. After the holes are properly aligned, fasten with (1) One #12 x 1 1/2" Pan Head Phillips Screw in the pre-drilled hole on the right side of the bench end.

Note: Do not tighten screws completely. This will be done in a later step.

Step #3:

Align the pilot holes on the bull-nosed bench board (B) to the pre-drilled holes on the left side of the bench ends. After the holes are properly aligned, fasten with (1) One #12 x 1 1/2" Pan Head Phillips Screw per bench end.

Note: Be sure to tighten screws completely after this step.

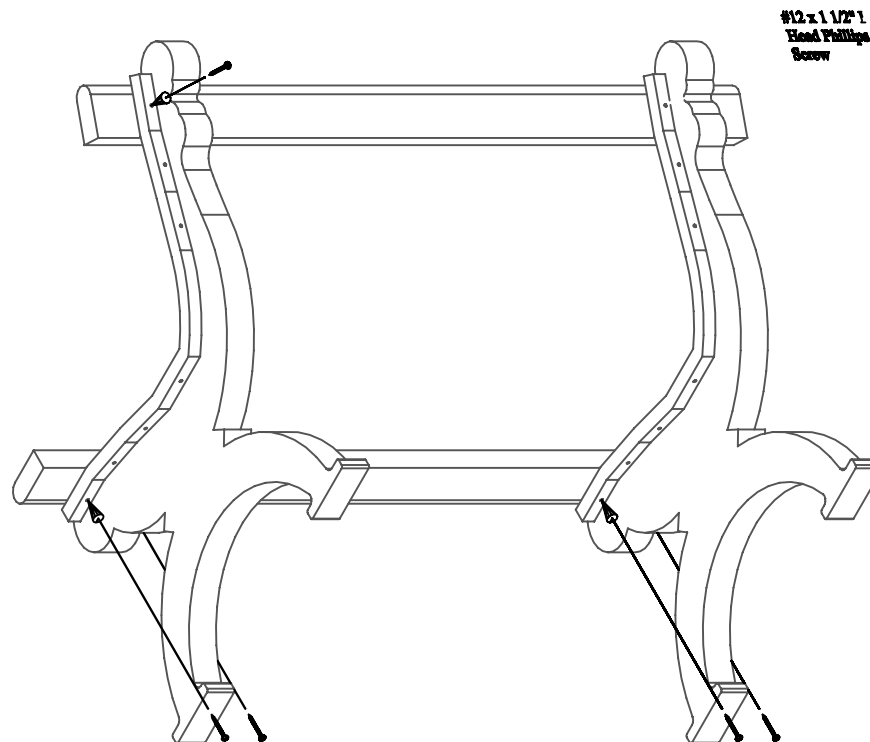

Step #4:

Place a second bull-nosed bench board (B) on position 7. Repeat Steps 1 - 3 to attach. Use (1) One #12 x 1 1/2" Pan Head Phillips Screw per hole to fasten.

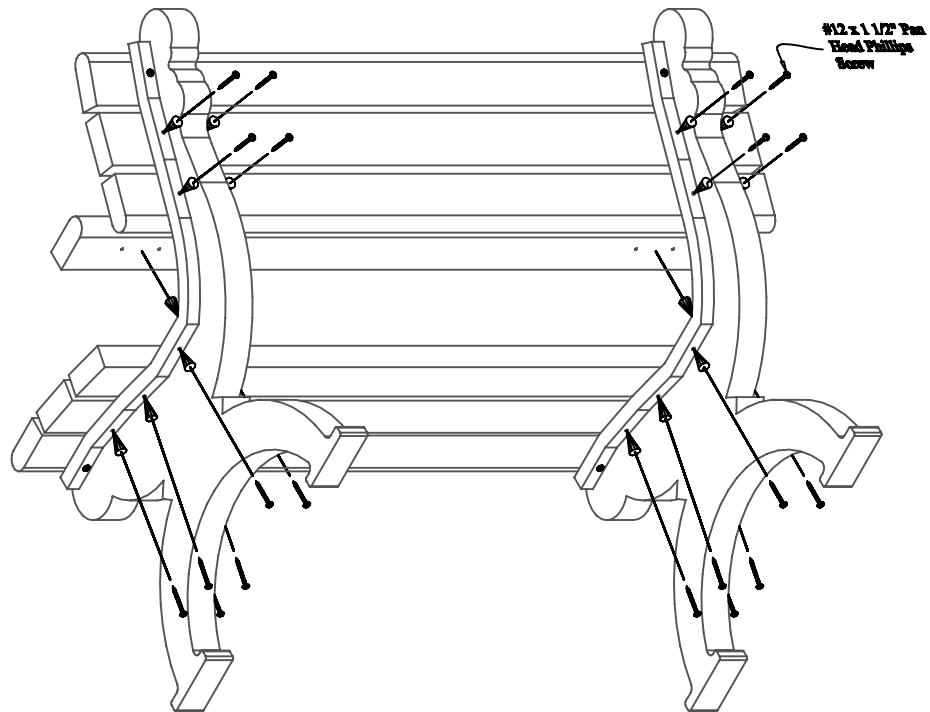

Step #5:

Repeat Steps 1 - 3 to attach bench boards (A) on positions 2, 5 & 6 and bull-nosed bench boards (B) on positions 3 & 4. Use (1) One #12 x 1 1/2" Pan Head Phillips Screw per hole to fasten.