

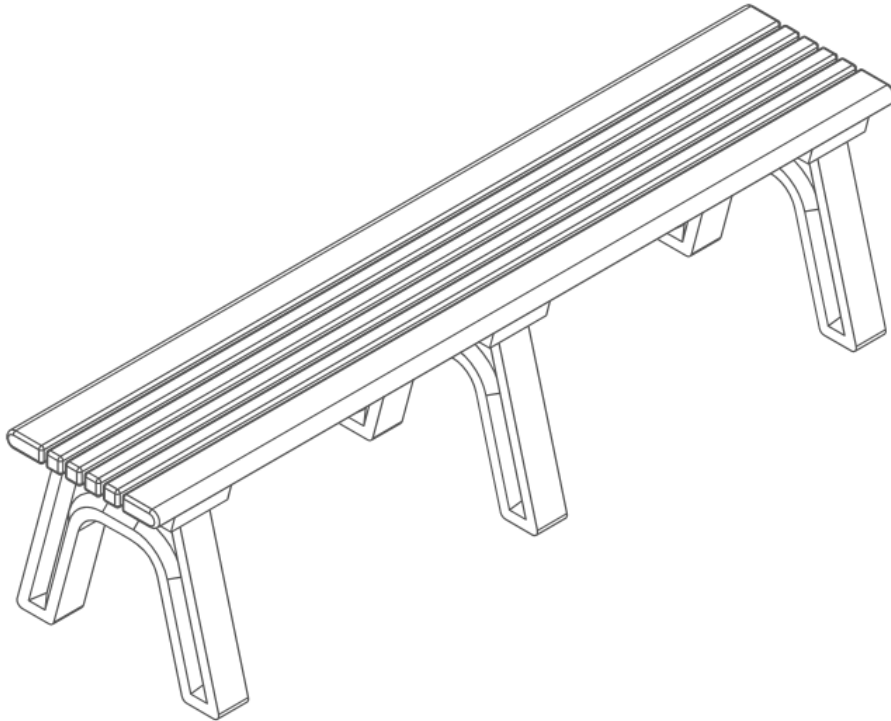

6ft Cambridge Flat Park Bench

SKU: 488be105-2



Before assembly, please make sure all components are included.



(1) - One Fastener Pack

FP - Fastener Pack

C - Bench End



C - Bench End



C - Bench End



(3) - Three Bench Ends

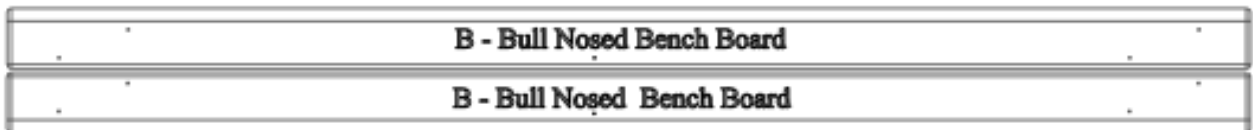

(2) - Two Bull Nosed Bench Boards

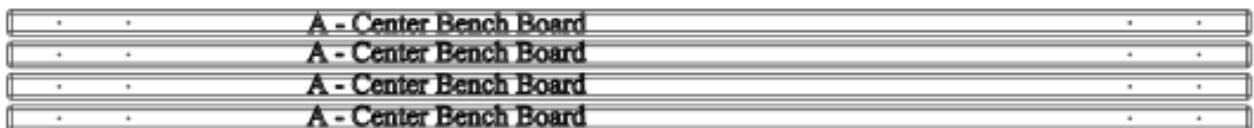

(4) - Four Center Bench Boards

Before assembly, please make sure all fasteners are included.

36 #12 x 2 1/2" Flat Head Phillips Screw



Also needed for this assembly will be the following materials:

1 - #3 Phillips Drive Bit

Step #1:

Place the Center Bench Boards on a level surface with the pilot holes facing up. On each side of the Center Bench Boards place (1) Side Bench Board with the pilot holes closest to the Center Bench Boards and facing up.

#12 x 2 1/2" Flat Head
Phillips Screw

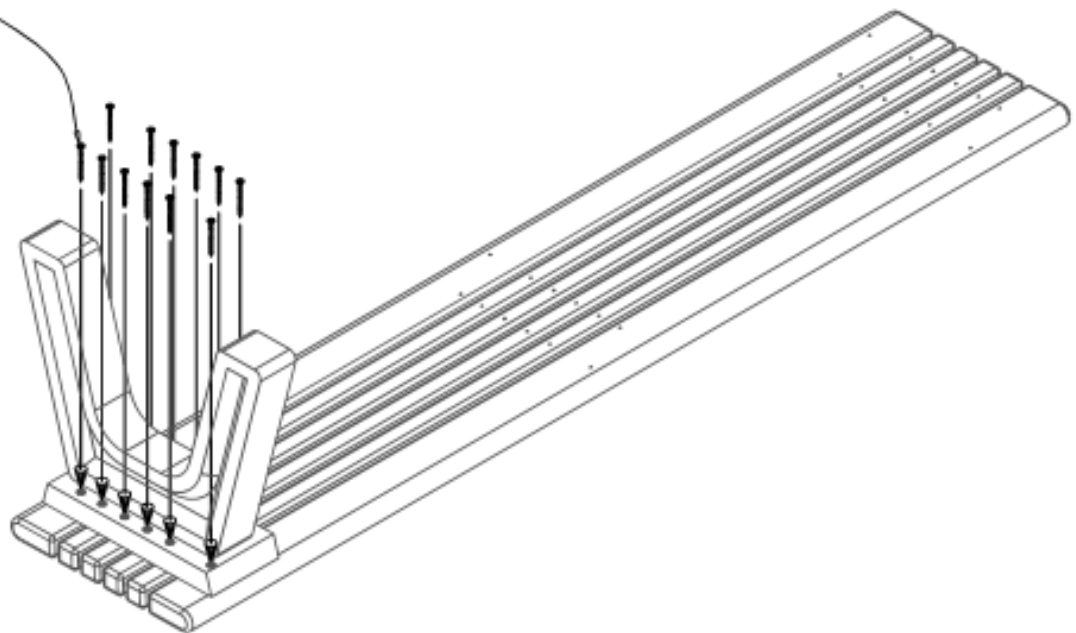

Step #2:

Place (1) Bench End in position as shown above being sure to align the pre-drilled holes to the pilot holes in the bench boards. After the holes are properly aligned, fasten with (1) #12 x 2 1/2" Flat Head Phillips Screw per hole to secure.

Note: Do not tighten screw completely. This will be done in a later step.

Step #3:

Place the remaining Bench Ends in position as shown above being sure to align the pre-drilled holes to the pilot holes in the bench boards. After the holes are properly aligned, fasten with (1) #12 x 2 1/2" Flat Head Phillips Screw per hole to secure.

Note: Be sure to tighten all screws completely after this step.

