

RENAISSANCE PARK BENCH - 60"

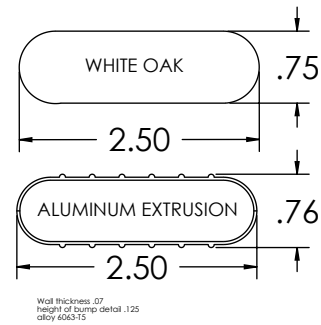

Engineered with cross-bolting to prevent end play

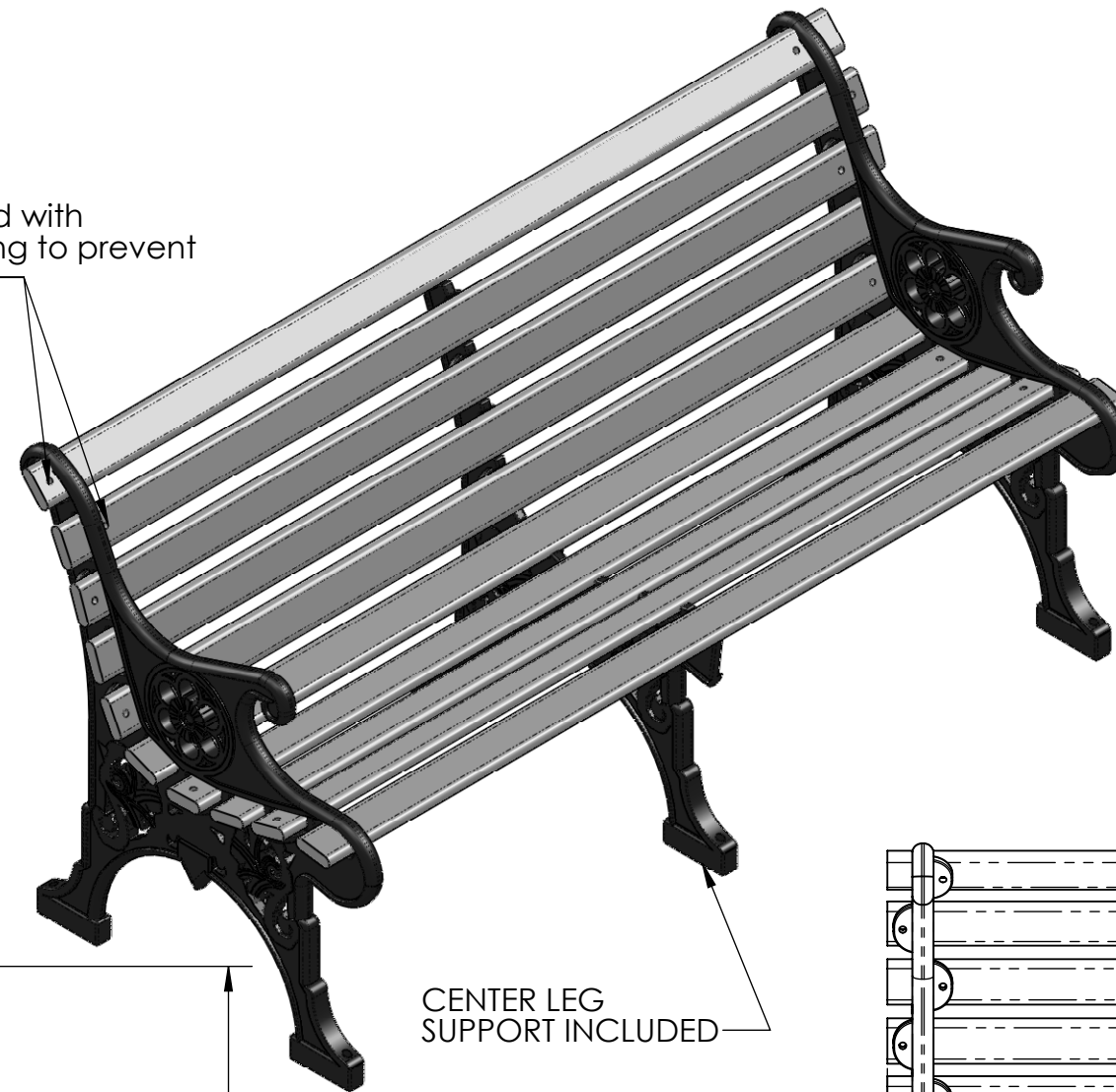

CENTER LEG SUPPORT INCLUDED

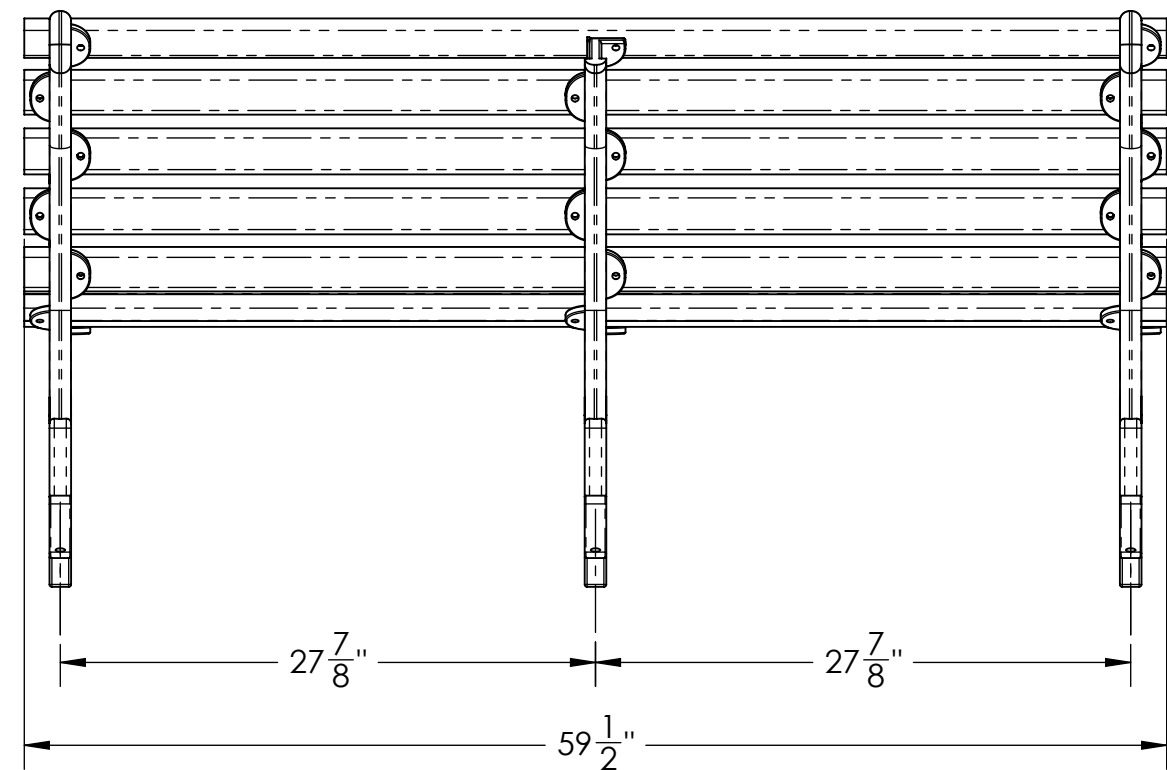
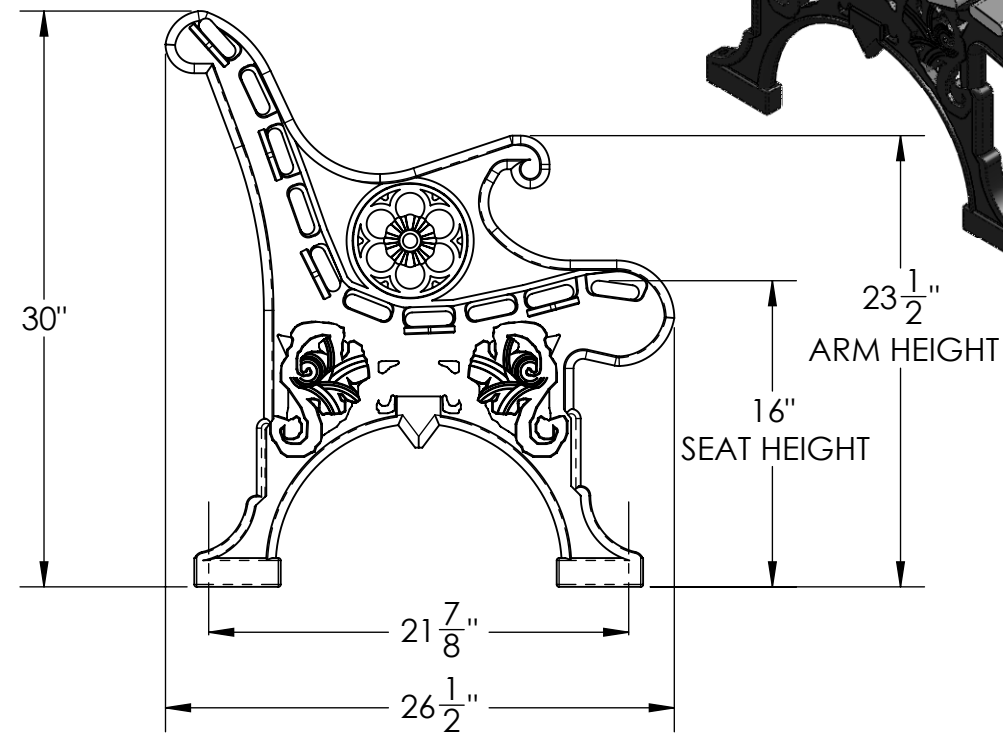

FRAME

- **Material:** Cast aluminum poured in permanent molds
- **Finish:** Electro static powder coating
- **Color:** Black, White, Green, Tan, Dk. Brown, Dk. Green, Bronze and Blue.

WOOD RAILS

- **Material:** FAS White Oak
- **Size:** 2 1/2" wide by 3/4" milled two edges 3/4" half round
- **Number of Rails:** 10
- **Finish:** PENOFIN® impact impregnated
- **Maintenance:** Apply PENOFIN® as necessary. Follow manufacture's instructions.

HARDWARE

- **Carriage Bolts:** 1/4"-20 steel zinc plate, yellow dipped
- **Nuts:** 1/4" steel zinc plate

BOLT DOWN DETAIL

VICTORIAN and RENAISSANCE benches can be drilled for permanent attachment

