

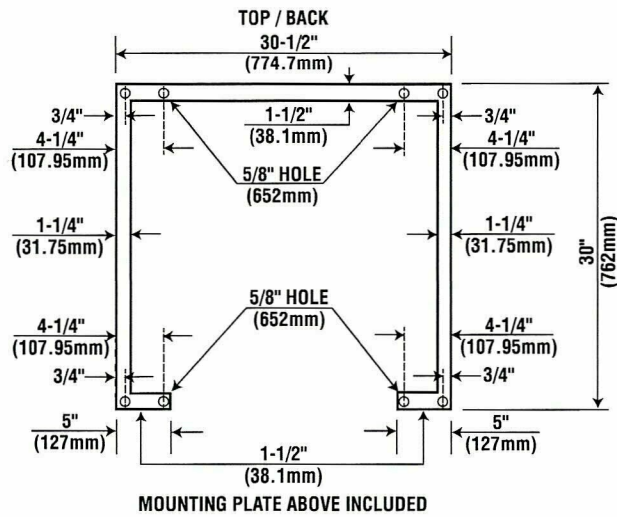

Dual Fountain and  
Recessed Water Bottle Filler Station  
Mounting: Wall Mount

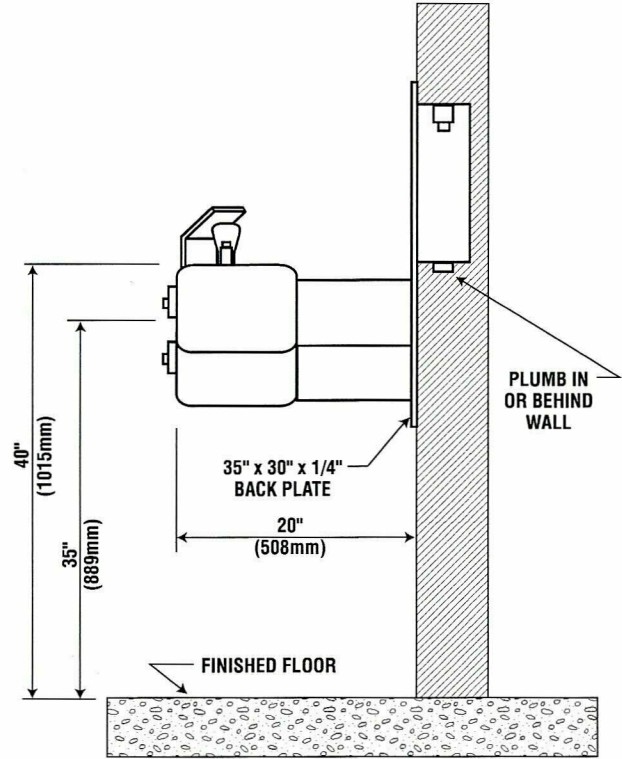
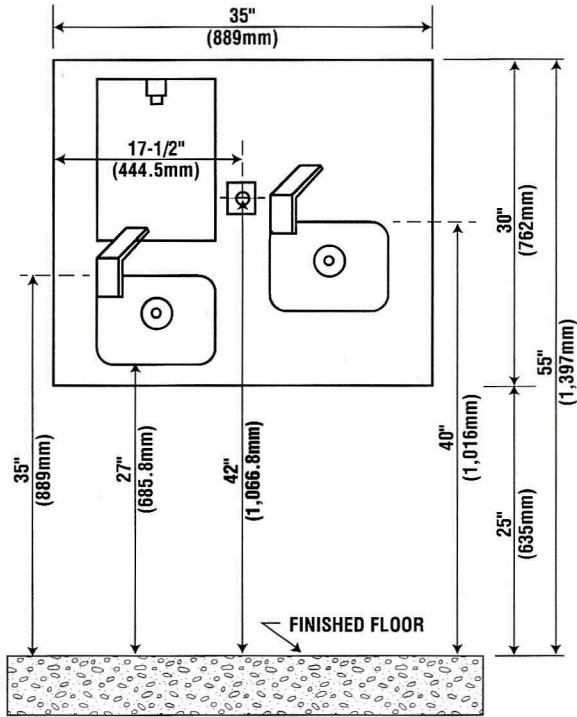

NOTE: THESE ROUGH-IN DIMENSIONS  
MAY VARY 1/2" (13 mm) PLUS OR MINUS

Note: All dimensions subject to manufacturing variance of plus or minus 1/4" (6 MM).



Dual Fountain and  
Recessed Water Bottle Filler Station  
Mounting: Wall Mount

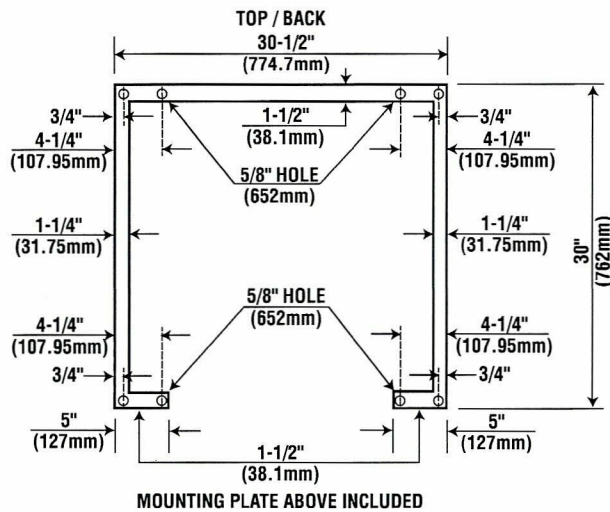
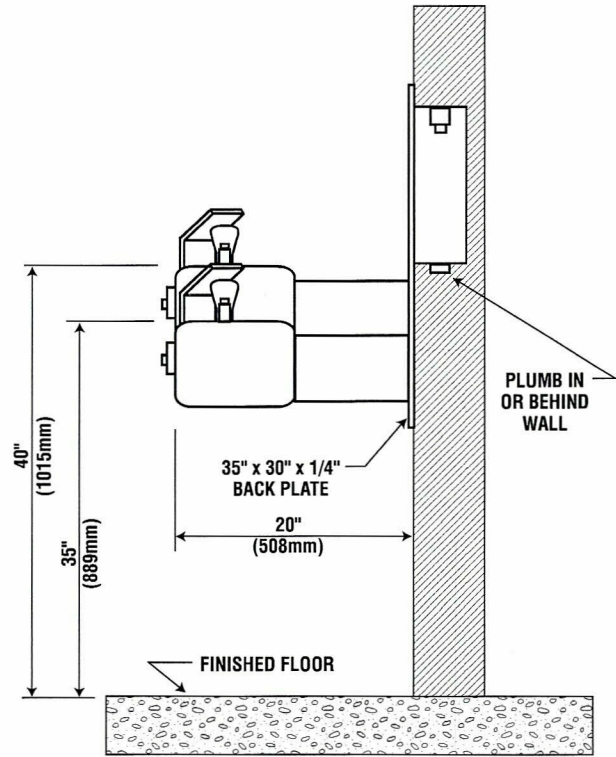
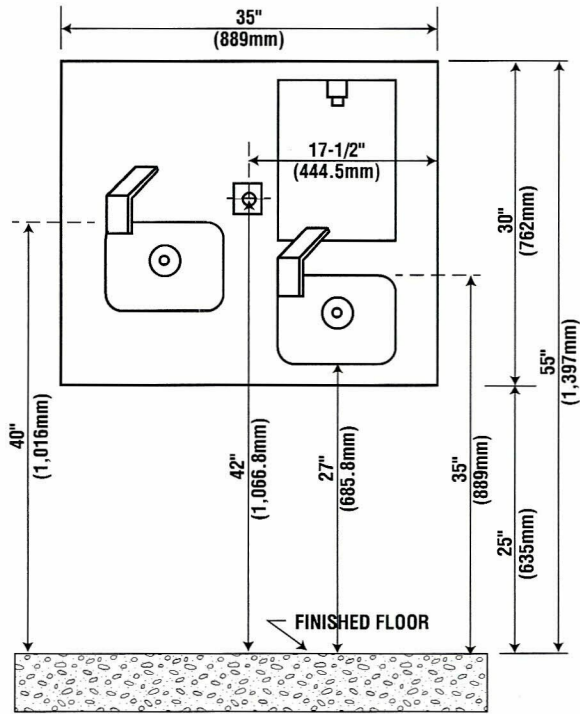

NOTE: THESE ROUGH-IN DIMENSIONS  
MAY VARY 1/2" (13 mm) PLUS OR MINUS

Note: All dimensions subject to manufacturing variance of plus or minus 1/4" (6 MM).