

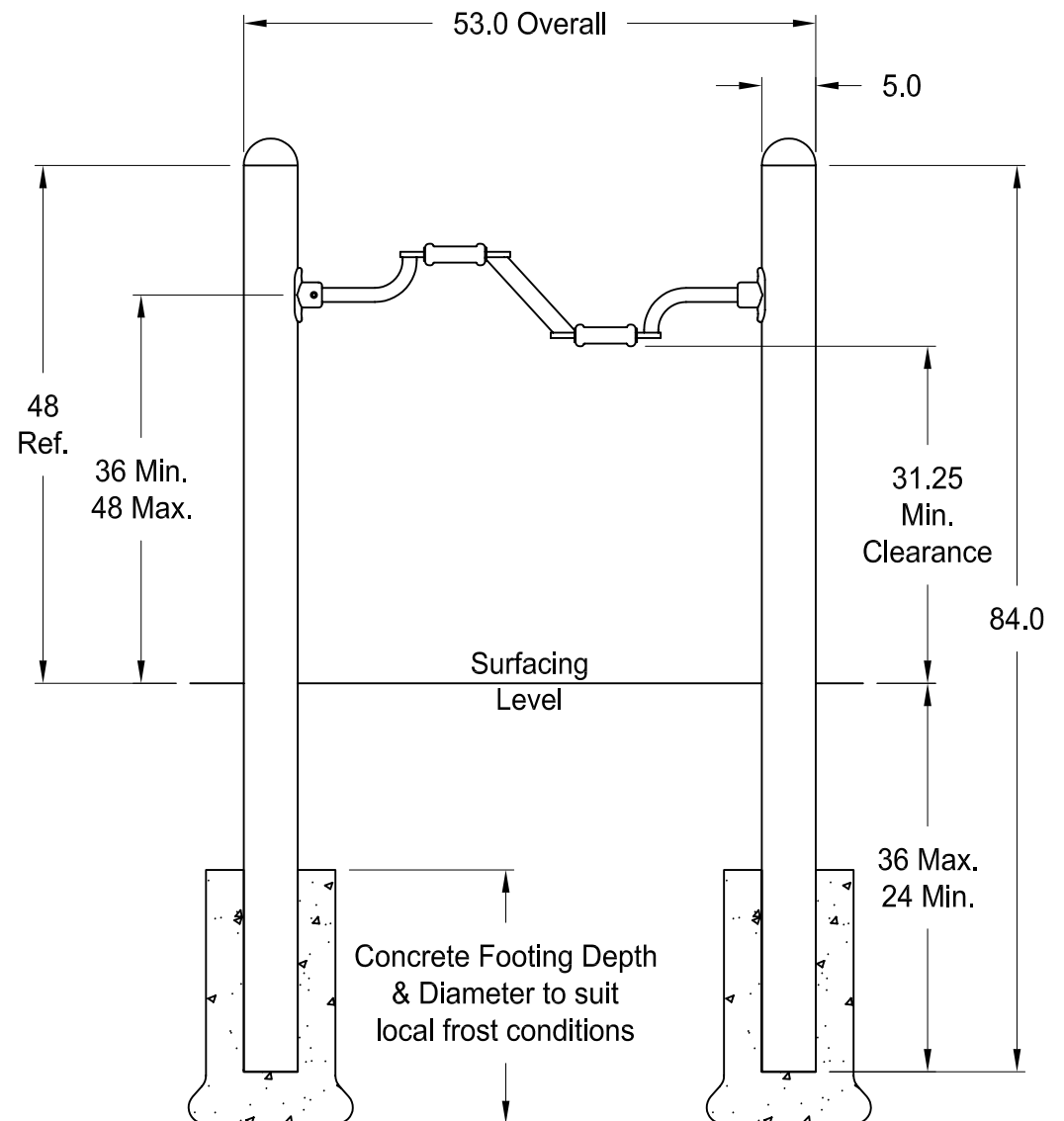

# Hand Bike- Single

SKU: N0Jft150

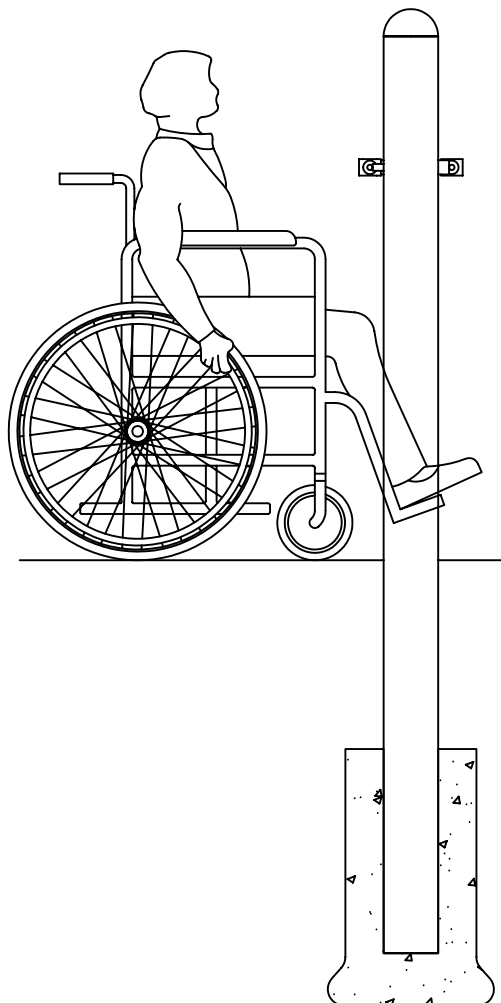
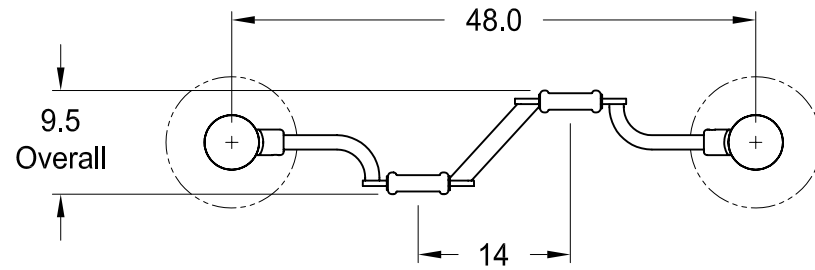

Note: Completely assemble unit prior to pouring concrete footings.  
Dimensions shown are in inches.



# Hand Bike- Single

SKU: N0Jft150

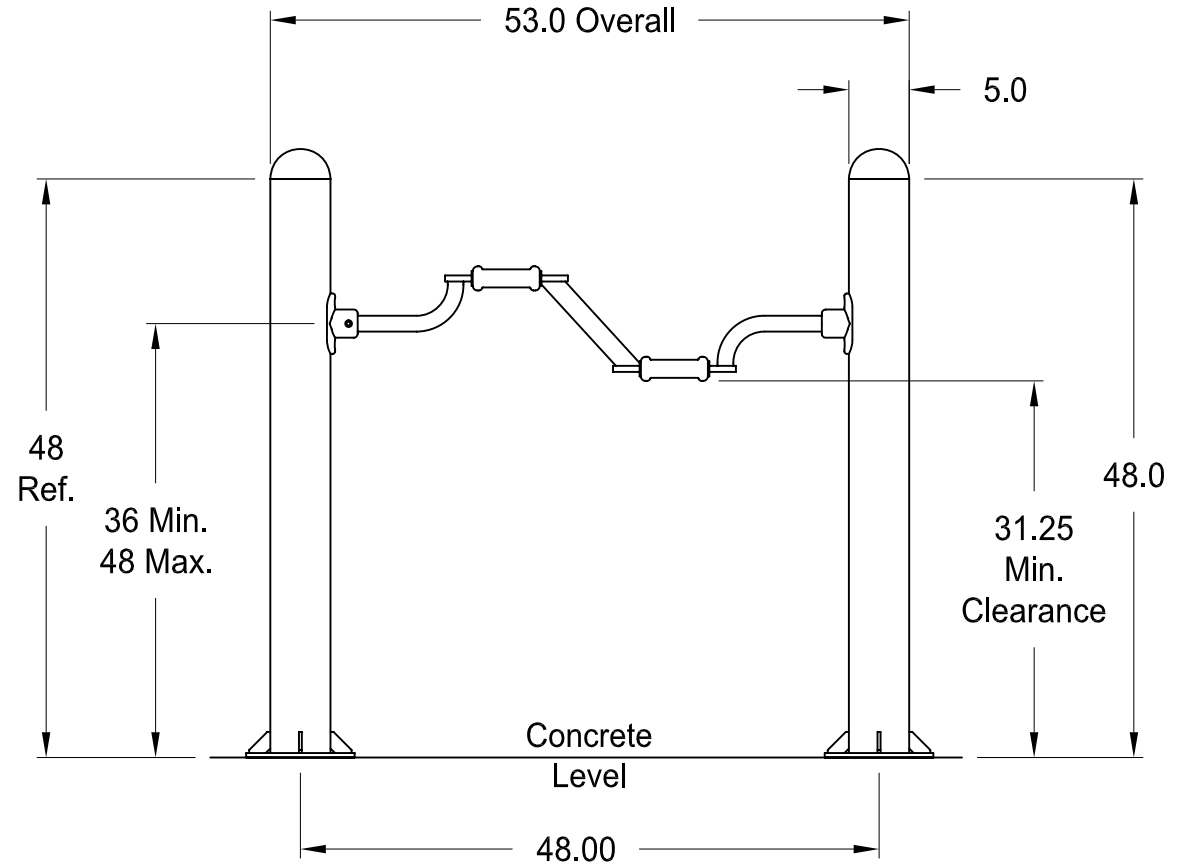
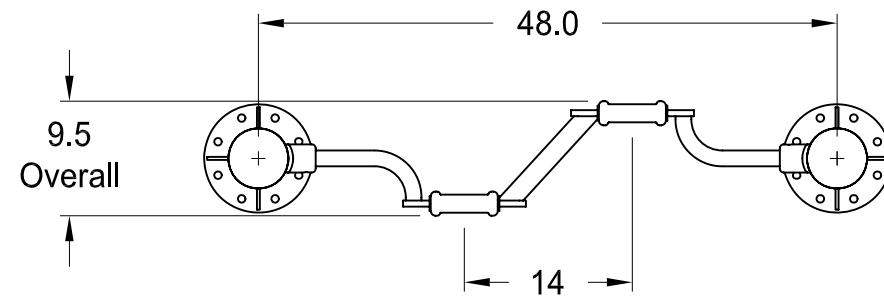
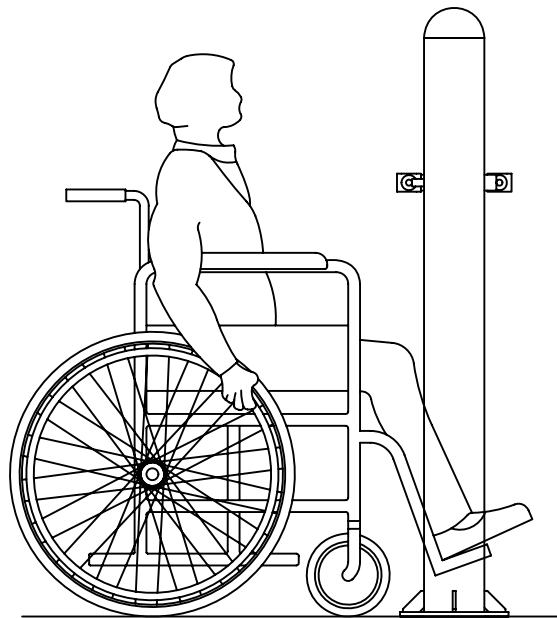

Suggested Anchoring Hardware for Surface Mount Plate:  
 7/16" to 1/2" diameter x 4" long, expanding wedge bolts,  
 4 bolts minimum / 8 bolts maximum. Use Base Plate as a template  
 for locating the anchor bolts.

Note: Anchoring is not included as it is impossible to foresee all possible mounting surface conditions. Therefore, anchoring hardware "Types" only are suggested for a typical concrete pad. The concrete should be fully cured and 4 to 6 inches thick.

Dimensions shown are in inches.

# Hand Bike- Double

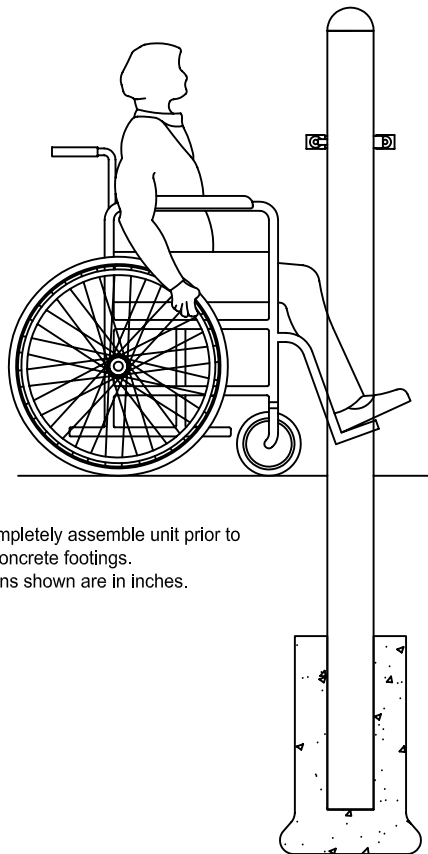
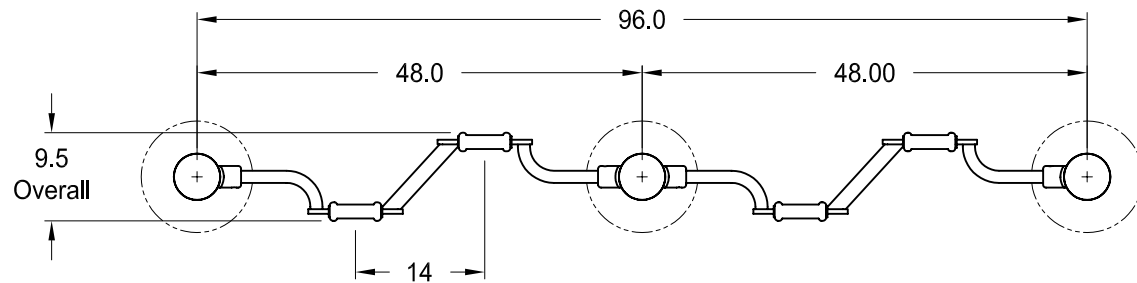
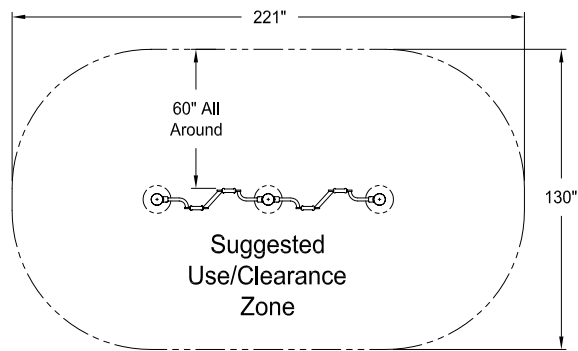

Note: Completely assemble unit prior to pouring concrete footings.  
Dimensions shown are in inches.

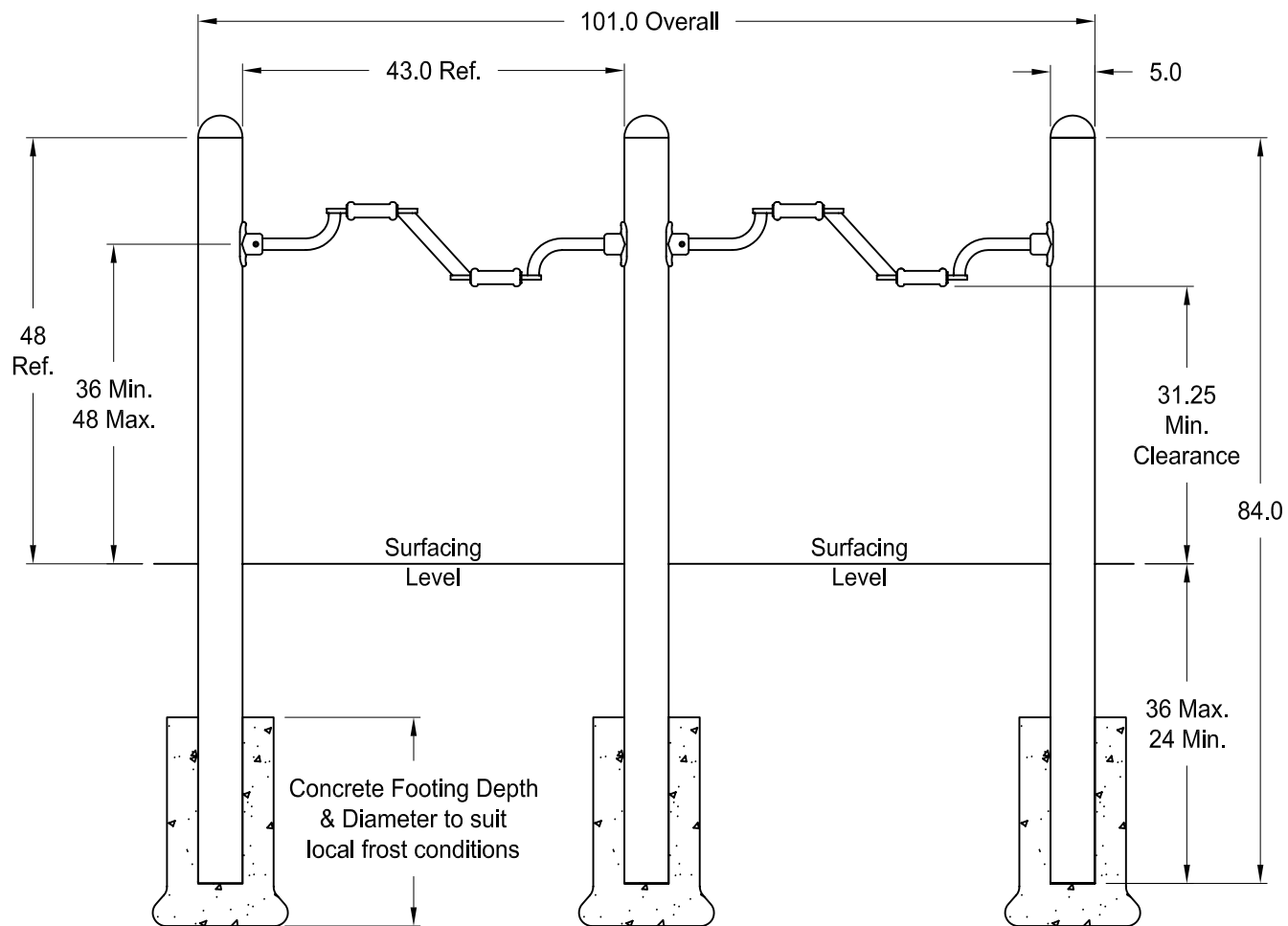



# Hand Bike- Double

SKU: N0Jft155

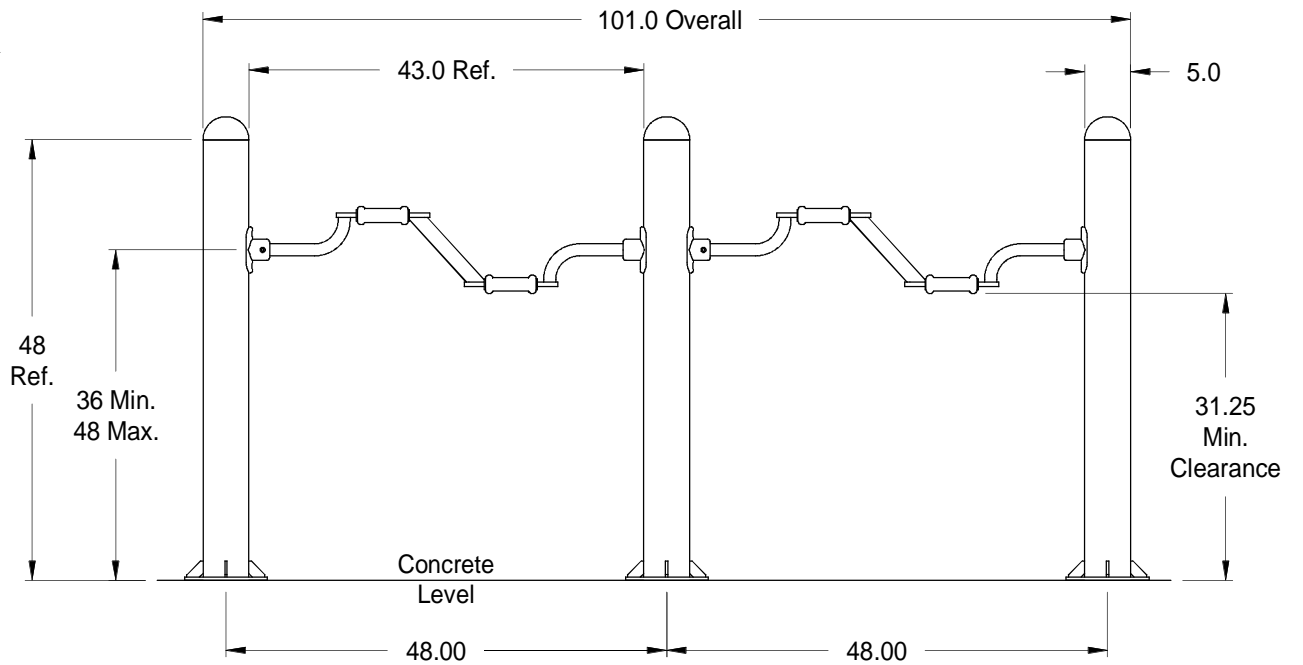
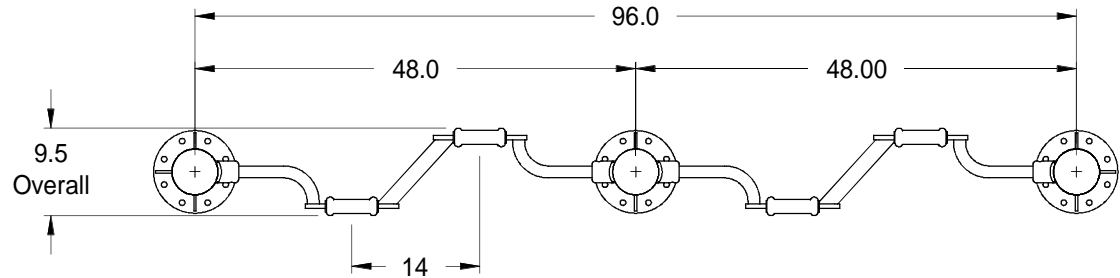
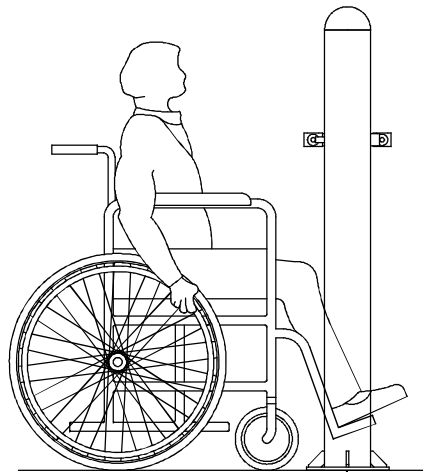
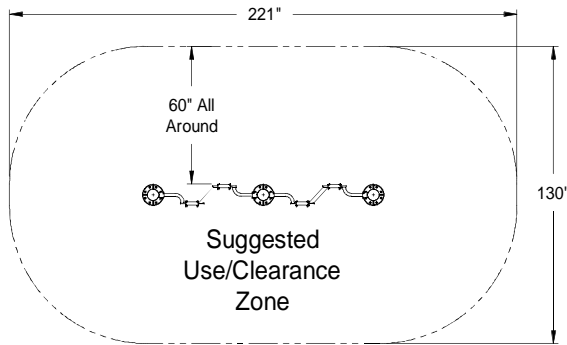

Suggested Anchoring Hardware for Surface Mount Plate:  
 7/16" to 1/2" diameter x 4" long, expanding wedge bolts,  
 4 bolts minimum / 8 bolts maximum. Use Base Plate as a template  
 for locating the anchor bolts.

Note: Anchoring is not included as it is impossible to foresee all possible mounting surface conditions. Therefore, anchoring hardware "Types" only are suggested for a typical concrete pad. The concrete should be fully cured and 4 to 6 inches thick.