

# Harp

SKU: 813pg205

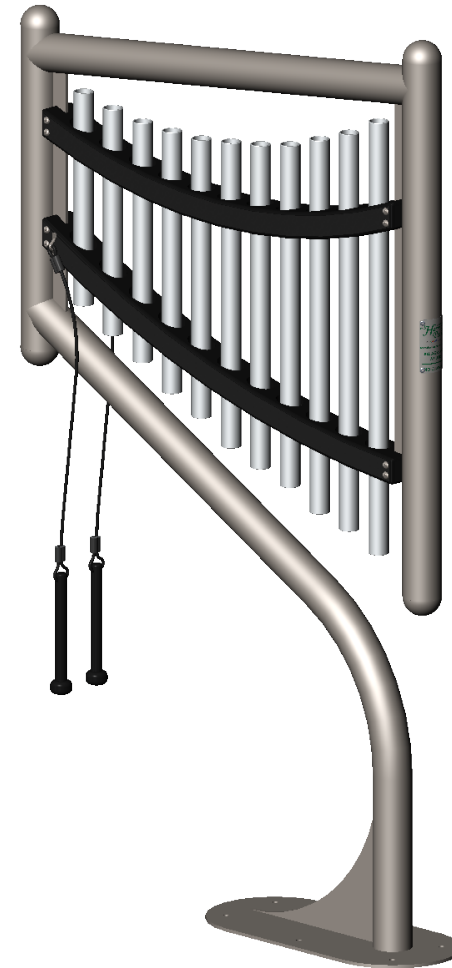
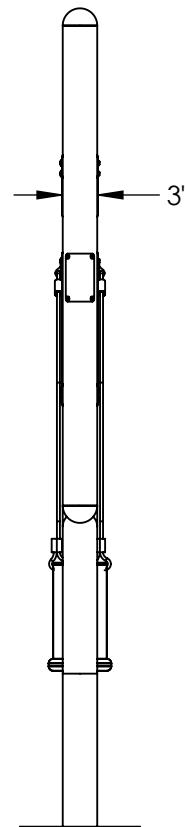
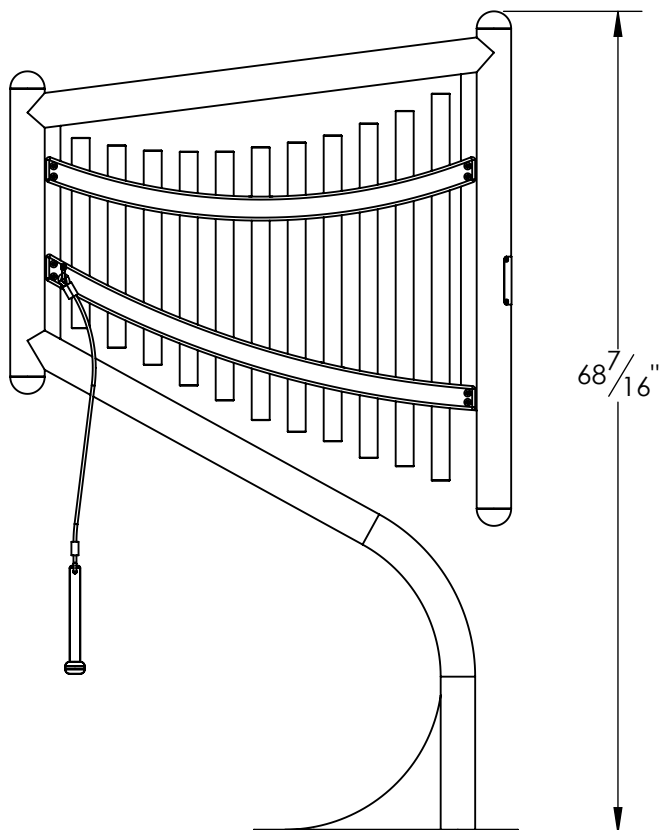
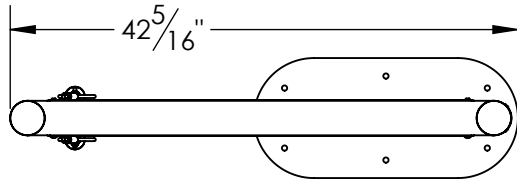

## Main Features:

- C Major Pentatonic
- Powder Coated Steel Frame
- Anodized Aluminum Chimes
- Stainless Steel Hardware

## Contents:

- SHEET 2 - Parts List and In Ground Surface Mount Installation

TITLE:  
Harp - Installation Guide

**Parts List:**

ITEM NO.	PART DESCRIPTION	QTY.
1	Harp Instrument Assembly	1
2	3/8"-16 Wedge Expansion Anchor, SS	6
3	35/64" Hex Nut Cap	6

**Step 1:** Determine installation location. Verify concrete footing is a minimum of 36" long x 24" wide x 6" thick. If the concrete pad is at an angle, steel washers are required to act as shims (Shims not provided). If there is not already an existing pad, approximately (5) 80lb. bags will be needed. Allow concrete to cure per concrete manufacturers guidelines.  
*(If a In-Ground appearance is desired recess the concrete pad 4" below finished grade)*

**Step 2:** With two people place the Instrument Assembly onto the concrete pad and mark the center of the holes on the surface mount plate. After you have made your marks, set aside the Instrument in order to drill for anchor holes. With a hammer or rotary drill, drill through concrete at marked locations. Drill to a minimum depth of 4". A 3/8" masonry drill bit will be needed.

**Step 3:** Place the Instrument back over the drilled out holes. Insert provided anchor bolts into aligned holes. Position anchor nut so that it is flush with the top of the bolt. Pound anchor bolts into the hole until the anchor washer is flush with the steel base. Tighten anchor bolts until they are snug. Cover remaining bolt sections with provided nut caps.

**Step 4:** Verify the correct placement, levelness, and finished height of the instrument. Also check for sufficient clearance around the instrument. A 36" perimeter around the instrument is recommended for wheelchair accessibility.

**Step 5:** If installing onto wet concrete, us the wet set anchor manufacturers guidelines for installation procedures.

