

Piper

SKU: 813pg190

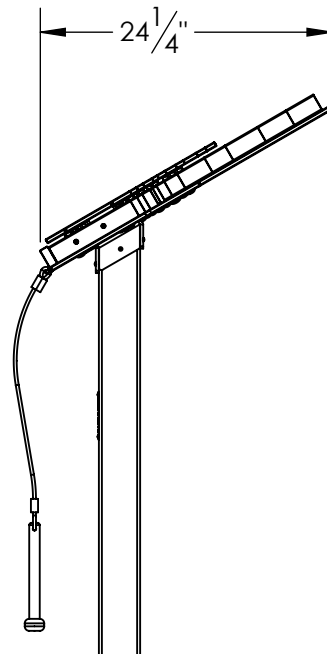
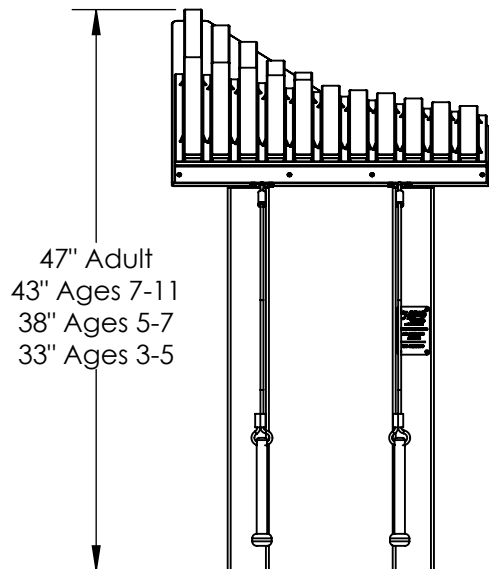
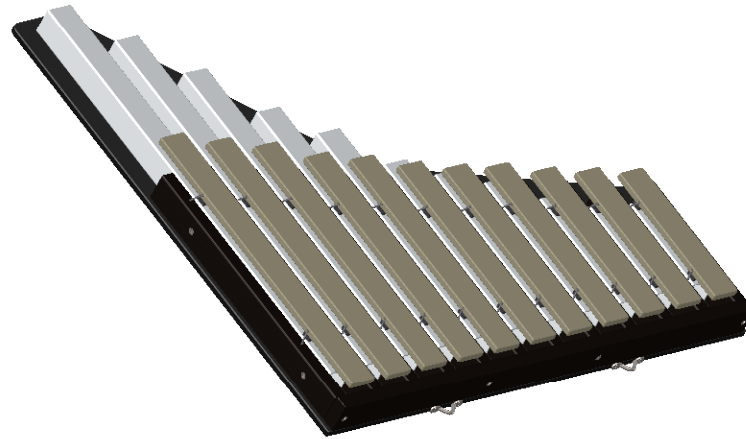
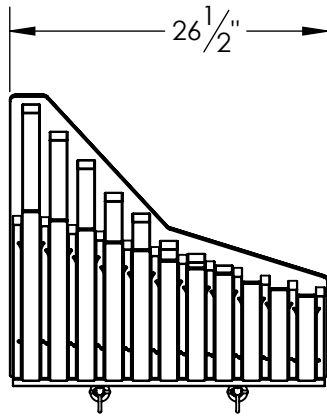

Main Features:

- C Major Pentatonic
- Recycled HDPE Frame
- Coated Fiberglass Bars
- Anodized Aluminum Resonators
- Stainless Steel Hardware

Contents:

- SHEET 2 - Parts List and Instrument to Post Installation
- SHEET 3 - In Ground Installation
- SHEET 4 - Surface Mount Installation

Parts List:

ITEM NO.	PART DESCRIPTION	In Ground - Recycled Post/QTY.	In Ground - Steel Post/QTY.	Surface Mount Recycled Post/QTY.	Surface Mount - Steel Post/QTY.
1	Piper Instrument Assembly	1	1	1	1
2	Small ABS Holster	2	2	2	2
3	In Ground Recycled Post, 72"lg.	2	-	-	-
4	In Ground Steel Post, 72"lg.	-	2	-	-
5	Surface Mount Recycled Post, 36"lg.	-	-	2	-
6	Surface Mount Steel Post, 36"lg.	-	-	-	2
7	Surface Mount Base, For Recycled Post	-	-	2	-
8	#8 Flat Head Screw, 1.25"lg. SS, T15 tamp	8	8	8	8
9	#8 Button Head Screw, 1.25"lg. SS, T15 tamp	10	-	10	-
10	#10-24 Button Head Machine Screw, 1"lg. SS, T25 tamp	-	10	-	10
11	5/16" Hex Head Lag Bolt, 5"lg. SS	-	-	4	-
12	3/8"-16 Wedge Expansion Anchor, SS	-	-	8	8
13	35/64" Hex Nut Cap	-	-	8	8
14	Security Driver	1	1	1	1

Step 1: Start by mounting the Holsters to the Instrument Back with the provided #8 Flat Head Screws and Driver. The Back comes predrilled. Screw heads should be flush with the Holster surface when properly installed. Holster should also be flush along the back. Drive Screws slowly to prevent stripping.

Step 2: With two people, situate the Instrument with Holsters installed onto the Posts. Posts come predrilled and/or tapped. Fasten the Instrument to the Posts with the provided #8 Button Head Screw for Recycled Posts or #10-24 Button Head Machine Screw for Steel Posts. Drivers are provided.

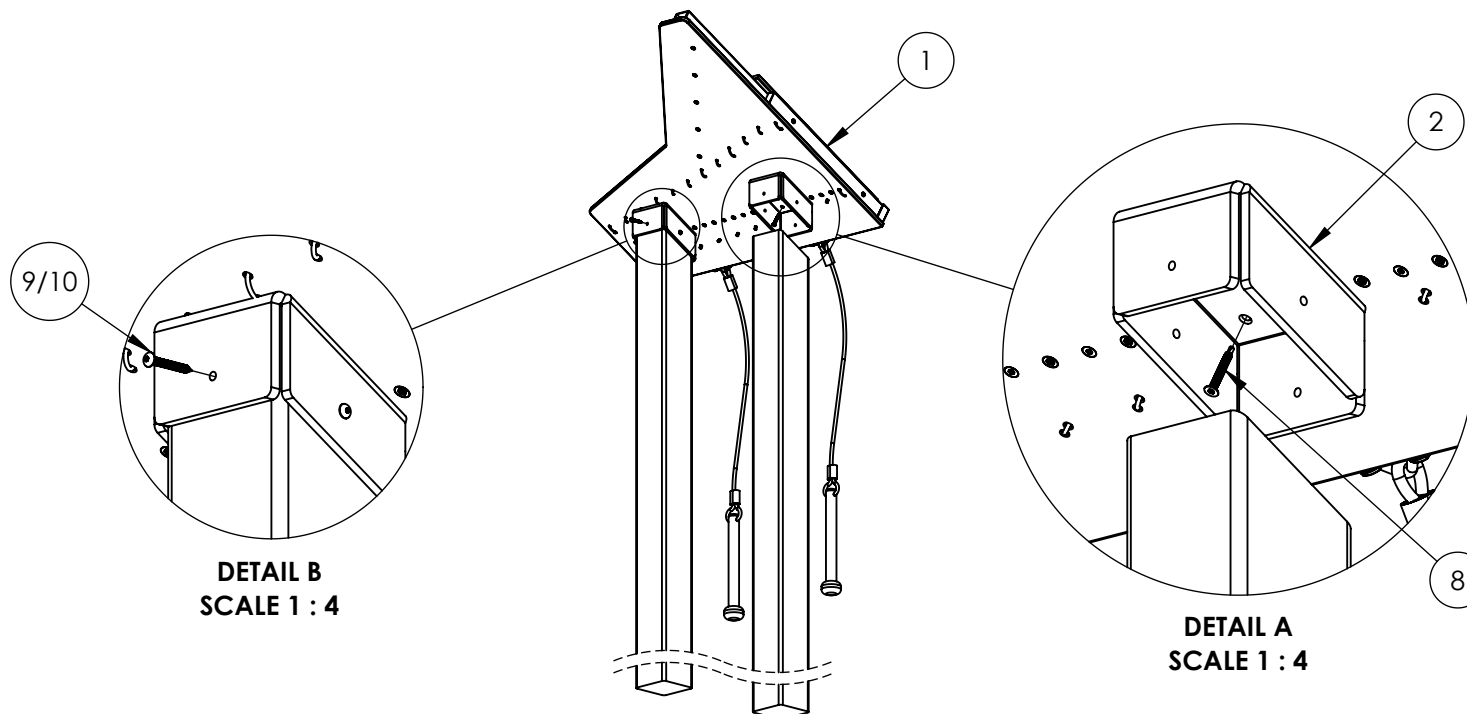

Step 1: Excavate two 10" diameter holes, 36" deep, and 13.75" on center at the installation location. Contractor can modify Post to desired height. **Post Length = Frost Depth (36" Recommended) + Finished Post Height**

Finished Post Height Guideline: (Ages 3-5, 22") (Ages 5-7, 27") (Ages 7-11, 32") (Adult, 36")

Step 2: With two people, lower the Posts with the Instrument attached into the excavated holes.

Step 3: Verify the correct placement, levelness, and finished height of the Instrument. Check for sufficient clearance around the Instrument, a 36" perimeter around the Instrument is recommended for wheelchair accessibility.

Step 4: Last pour concrete around the posts. It is recommended to brace the Instrument to hold it rigid while the concrete cures. Leave to set according to the concrete manufacturers guidelines. Approximately (6) 80lb. bags will be needed.

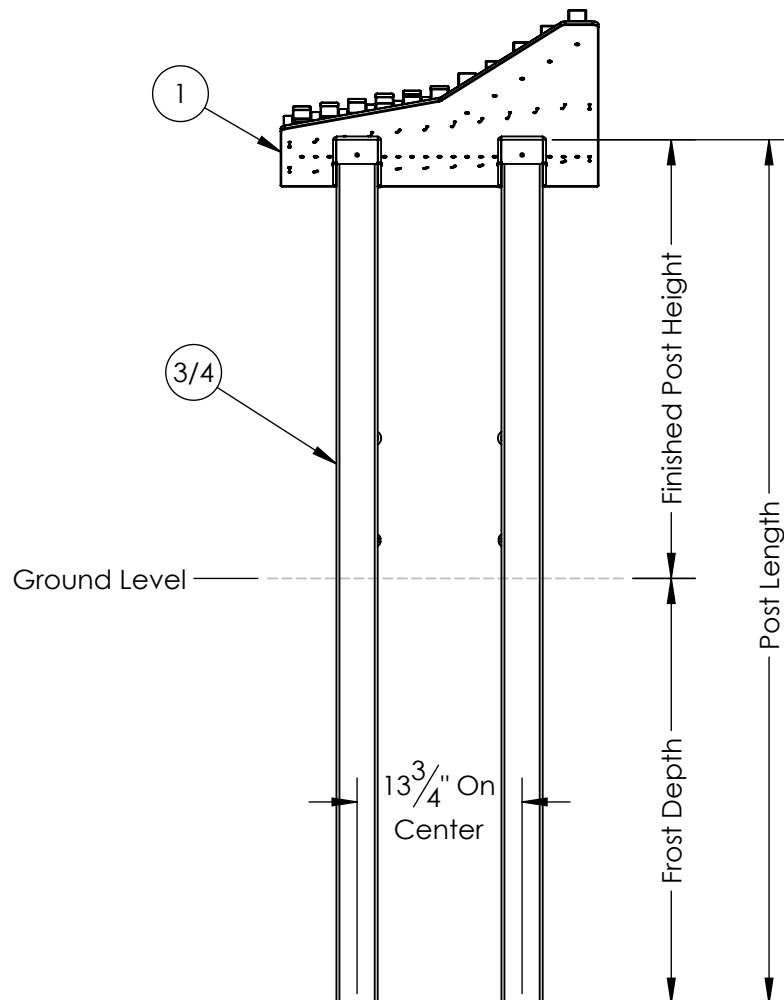

Step 1: Standard height for Surface Mount Posts are 36". The Recycled Posts may be modified in the field to the following heights:

(Ages 3-5, 22") (Ages 5-7, 27") (Ages 7-11, 32") (Adult, 36")

The height of Surface Mount Steel Posts can not be adjusted.

Step 2: Determine installation location. Verify concrete footing is a minimum of 36" long x 24" wide x 6" thick. If the concrete pad is at an angle, steel washers are required to act as shims (Shims not provided). If there is not already an existing pad, approximately (5) 80lb. bags will be needed. Allow concrete to cure per concrete manufacturers guidelines.

Step 3 (Recycled Post Only): Install the Surface Mount Bases to the bottom of the Posts. Align the holes on the Bases with the holes on the Posts. The Bases should fit snugly around the Posts. Fasten them together with the provided 5/16" Hex Head Lag Bolts.

Step 4: With two people place the Instrument Assembly with Posts attached onto the concrete pad and mark the center of the holes on the surface mount bases. After you have made your marks, set aside the Instrument in order to drill for anchor holes. With a hammer or rotary drill, drill through concrete at marked locations. Drill to a minimum depth of 4". A 3/8" masonry drill bit will be needed.

Step 5: Place the Instrument back over the drilled out holes. Insert provided anchor bolts into aligned holes. Position anchor nut so that it is flush with the top of the bolt. Pound anchor bolts into the hole until the anchor washer is flush with the surface mount bases. Tighten anchor bolts until they are snug. Cover remaining bolt sections with provided nut caps.

Step 6: Verify the correct placement, levelness, and finished height of the Instrument. Check for sufficient clearance around the Instrument, a 36" perimeter around the Instrument is recommended for wheelchair accessibility.

Step 7: If installing onto wet concrete, us the wet set anchor manufacturers guidelines for installation procedures.

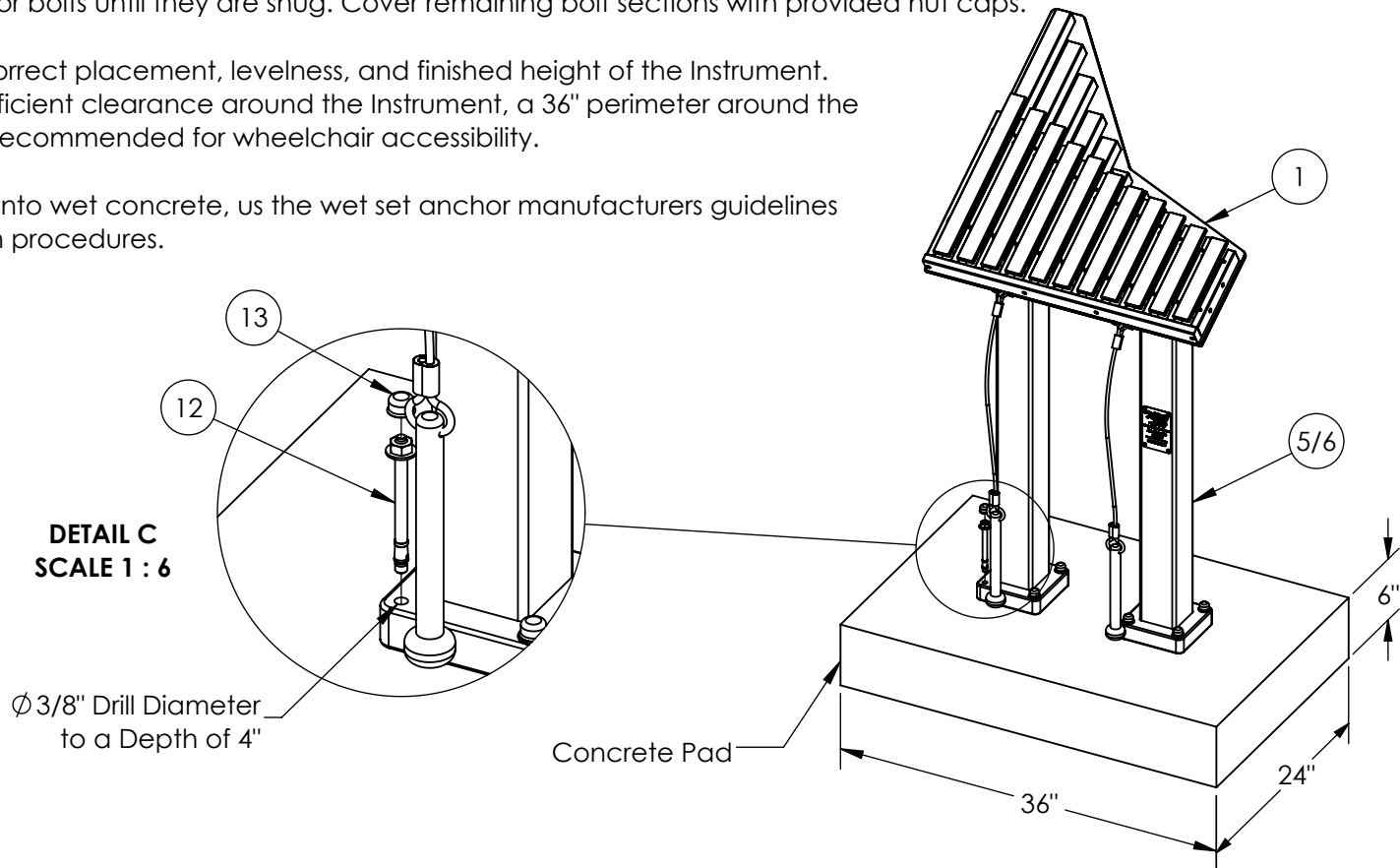

TITLE:
Surface Mount Installation