

# ROUND RACK



Simple. Stylish. Secure.

Clean lines and simple functionality make the Round Rack welcome addition to bike parking. Much like a Hoop Rack, but with a more stylish appearance, the Round Rack enhances public spaces while providing secure parking for two bikes.

554br345

## YOUR LOGO HERE

Customize the Round Rack and brand your bike parking



### FINISH OPTIONS

Galvanized



Stainless



### MOUNT OPTIONS

Surface

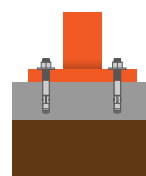

In-Ground



### Powder Coat

White	Black	Light Gray RAL 7042	Deep Red RAL 3003	Yellow RAL 1023
CNH Bright Yellow	Orange RAL 2004	Blue RAL 5005	Sky Blue RAL 5015	Hunter Green RAL 6005
Light Green RAL 6018	Green RAL 6016	Sepia Brown RAL 8014	Bronze	Silver 9007
Dark Purple	Flat Black	Wine Red RAL 3005	Beige RAL 1001	Iron Gray 7011

### Thermoplastic

Black	Green	Red	Blue	Gray	Brown
-------	-------	-----	------	------	-------

# ROUND RACK

## Submittal Sheet

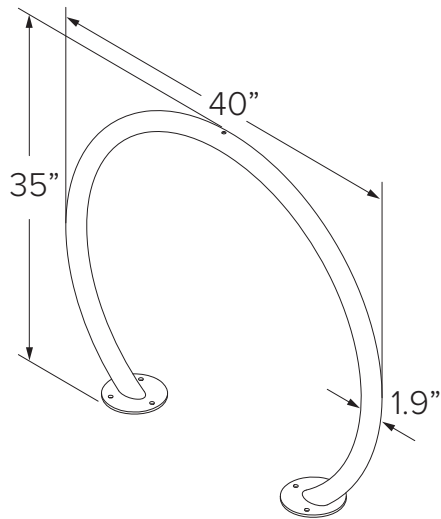

**CAPACITY** 2 Bikes

- MATERIALS**
- Standard**  
1.5" schedule 40 pipe (1.9" OD)
  - Lightweight**  
1.5" schedule 10 pipe (1.9" OD)

- FINISHES**
- Galvanized**  
An after fabrication hot dipped galvanized finish is our standard option.
  - Powder Coat**  
Our powder coat finish assures a high level of adhesion and durability by following these steps:  
1. Sandblast  
2. Epoxy primer electrostatically applied  
3. Final thick TGIC polyester powder coat
  - Thermoplastic**  
In addition to an increased thickness (8-10mils), the thermoplastic finish covers a galvanized layer and offers superior impact resistance over powder coating.
  - Stainless**  
Stainless Steel: 304 grade stainless steel material finished in either a high polished shine or a satin finish.

- MOUNT OPTIONS**
- In-ground**  
In ground mount is embedded into concrete base. Specify in ground mount for this option.
  - Surface**  
Foot Mount has two 6" circular feet with three anchors per foot. Specify foot mount for this option.

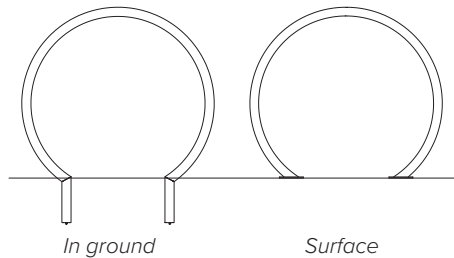

**ROUND RACK**  
Setbacks

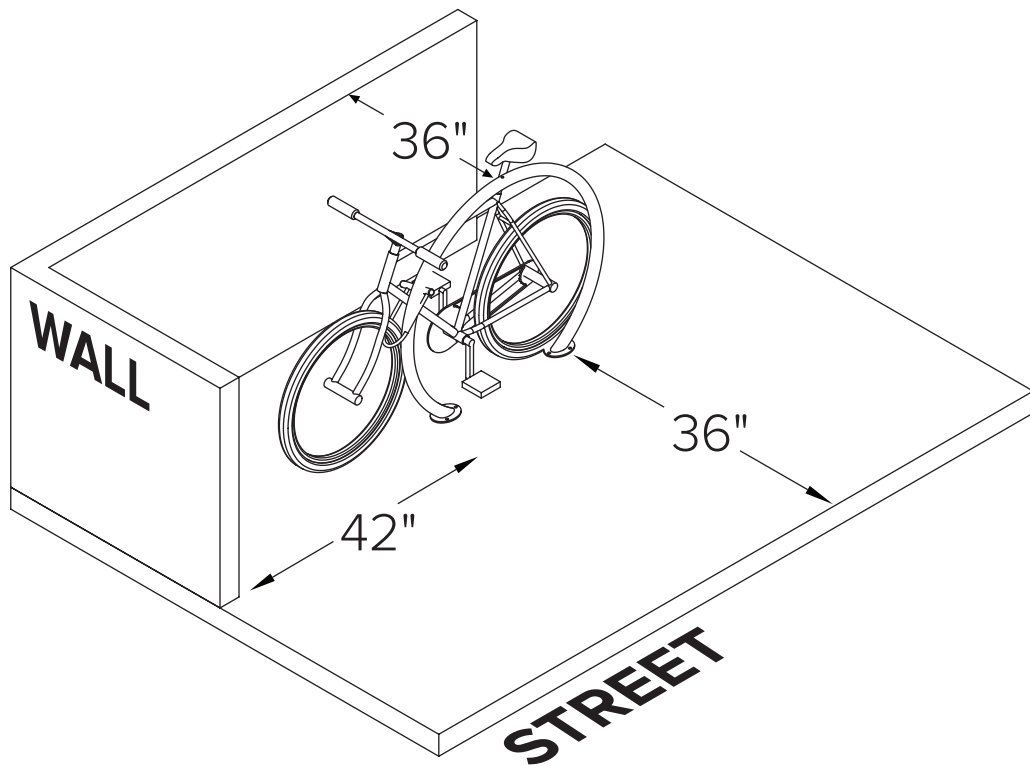

## ROUND RACK

# Installation Instructions – Surface Mount

---

### TOOLS NEEDED

Tape Measure  
Marker or Pencil  
Masonry Drill Bit  
Drill (Hammer drill recommended)  
Hammer  
Wrench 9/16"  
Level

### RECOMMENDED BASE MATERIAL

Solid concrete is the best base material for installation. To ensure the proper anchors are shipped with your rack, ask your representative which anchor is appropriate for your application. Be sure nothing is underneath the base material that could be damaged by drilling.

---

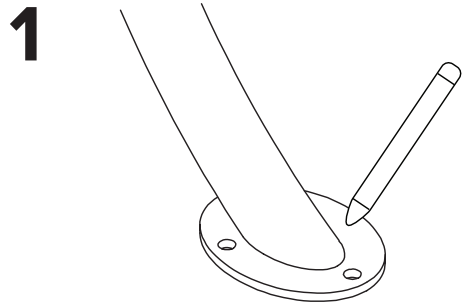

Place the rack in the desired location. Use a marker or pencil to outline the holes of the flange onto the base material.

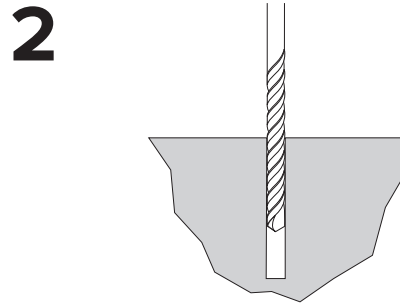

Drill 3/8" diameter holes 3" deep into surface. Make sure the holes are at least 3" away from any cracks in the base material.

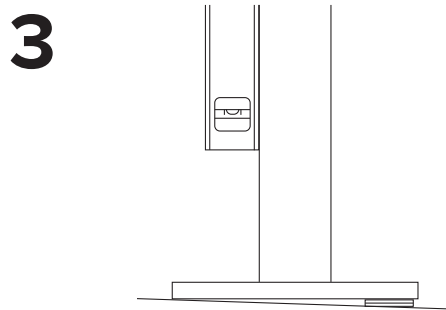

Place rack (and washers to level rack if necessary) over holes.

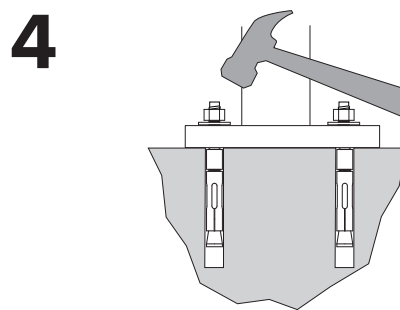

Thread nuts onto anchors, leaving approximately 1/4" of the anchor protruding, and tap into surface. Tighten nuts down to secure rack.

## ROUND RACK

# Installation Instructions – In Ground Mount

### TOOLS NEEDED

Level  
Cement mixing tub  
Shovel  
Trowel

Hole coring machine with 4" bit  
Access to water hose  
Materials to build brace (see "Install Tip" at bottom of page)

### INSTALLING INTO EXISTING SIDEWALK

Core holes no less than 3" diameter (4" recommended) and 10" deep into sidewalk. Fill holes with Por-Rok or epoxy grout. Place rack into holes, making sure the rack is level. 33"-36" of the rack should remain above the surface. If the rack is less than 33" high, it will not support the bike adequately. Make sure the rack is level and held in place until the grout has set.

### INSTALLING INTO A NEW SIDEWALK

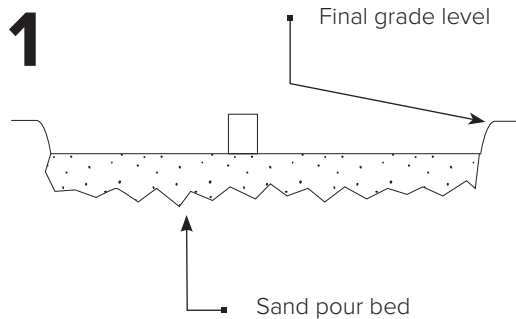

Place corrosion resistant sleeve (min. 3" inside diameter) in sand pour bed in exact location where rack will be installed. Make sure top of sleeve is at same level as desired finished concrete surface. Fill sleeve with sand to keep it in place and prevent it from filling with concrete.

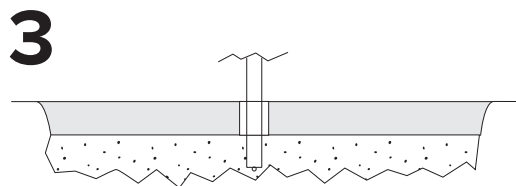

After appropriate cure time, dig out sand from sleeves and insert racks, making sure they are level and at the appropriate height. Pour in Por-Rok or epoxy grout and allow to set.

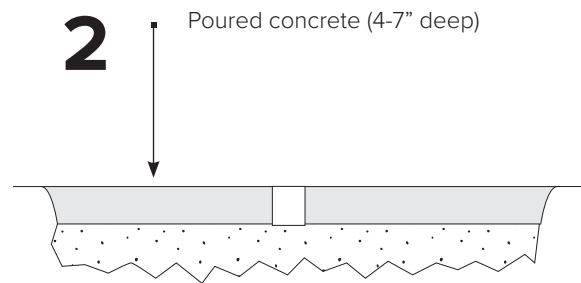

Pour concrete and allow to cure.

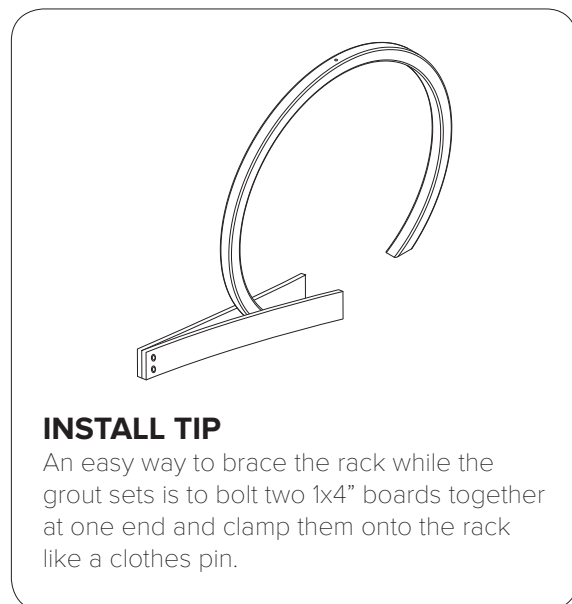

#### INSTALL TIP

An easy way to brace the rack while the grout sets is to bolt two 1x4" boards together at one end and clamp them onto the rack like a clothes pin.