



Patents US 9,498,880 and 9,505,124
Additional patent pending

Fixit® Plus

The Fixit Plus includes all the tools necessary to perform basic bike repairs and maintenance, from changing a flat to adjusting brakes and derailleurs. Stainless steel cables and tamper-proof fasteners securely attach tools to the stand, while the hanging arms allow pedals and wheels to spin freely while making adjustments. Add a second hanger for double sided access to the tools!

Additional Charge for adding a second hanger will apply

Fixit® Plus

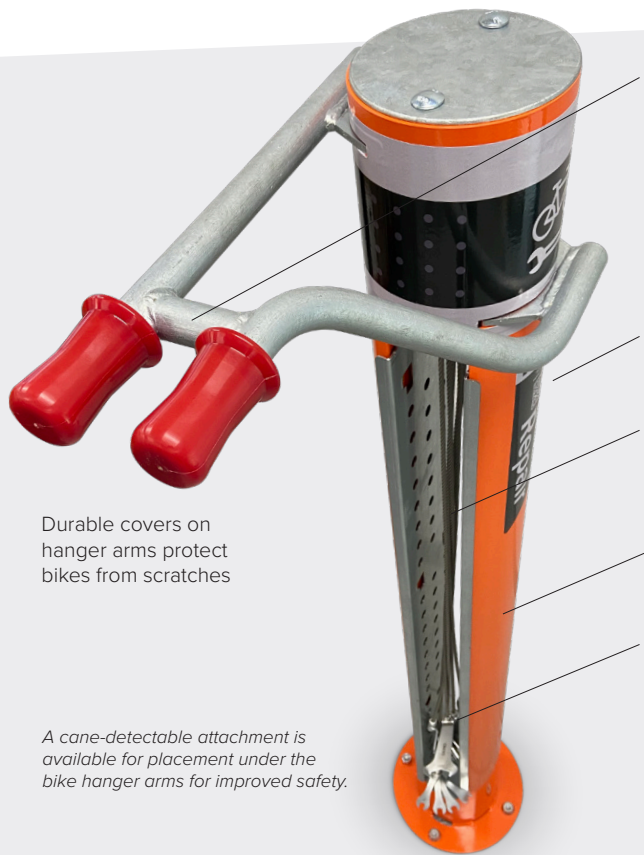

Hanger arms accommodate most types of bikes

QR code takes smart phone users to comprehensive bike repair web site

Tools are secured with stainless steel aircraft cables

Large surface area for sponsorship, branding, or way-finding signage

Includes most commonly used tools for simple bike maintenance



Tamper-resistant fasteners included!

Durable covers on hanger arms protect bikes from scratches

A cane-detectable attachment is available for placement under the bike hanger arms for improved safety.



Tools included:

- Philips and flat head screwdrivers
- 2.5, 3, 4, 5, 6, 8mm Allen wrenches
- T25 Torx wrench
- 32mm Headset wrench
- 15mm Pedal wrench
- 8, 9, 10, 11mm box wrenches
- Tire levers (2)



Orient arms to set the preferred height for hanging bikes



Add a second hanger for double sided access!



Add your choice of an Air Kit bike pump (sold separately) to keep your cyclists' tires topped up and ready to roll. The Air Kits feature our Metal Head™, a sturdy cast aluminum pump head with Presta and Schrader valve compatibility.

These public bike repair products require occasional maintenance and replacing of parts to remain serviceable.

FINISH OPTIONS

Galvanized



Powder Coat

- | | | | | |
|-------------------------|--------------------|-------------------------|-----------------------|--------------------------|
| White | Black | Light Gray
RAL 7042 | Deep Red
RAL 3003 | Yellow
RAL 1023 |
| CNH Bright Yellow | Orange
RAL 2004 | Beige
RAL 1001 | Iron Gray
RAL 7011 | Hunter Green
RAL 6005 |
| Light Green
RAL 6018 | Green
RAL 6016 | Sepia Brown
RAL 8014 | Bronze | Silver
RAL 9007 |
| Dark Purple | Flat Black | Wine Red
RAL 3005 | | |

Submittal Sheet

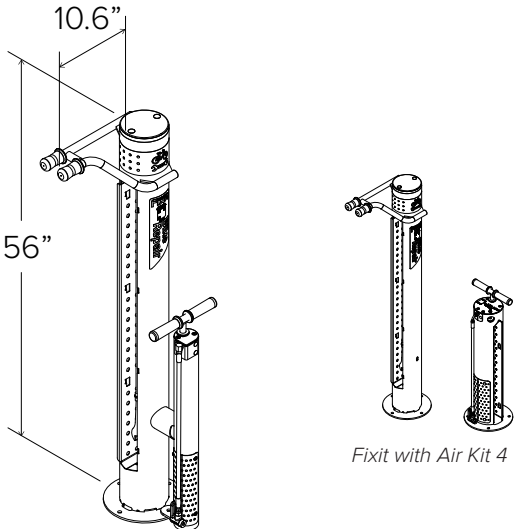

Fixit with Air Kit Prime

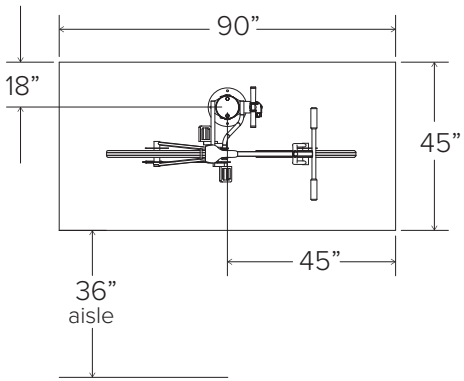

Minimum Footprint

An optional wheel catch is available to hold bikes with no kick stands

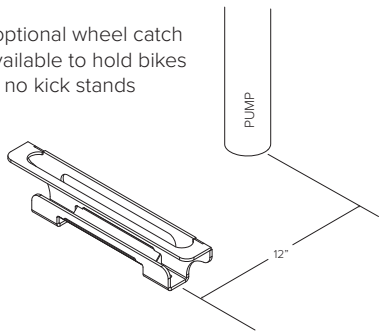

- CAPACITY**
- 1 Bike** (One set of hanger arms)
 - 2 Bikes** (Two sets of hanger arms)

- MATERIALS**
- Main body:** 6" x 12g tube
 - Bike Hanger:** 1" solid round bar
 - Foot:** 10" dia. x .25" plate
 - Tool tethers:** 3/16" stainless steel cable
 - Manual air pump**
 - Hand tools:**
 - Philips and flat head screwdrivers
 - 2.5, 3, 4, 5, 6, 8mm Allen wrenches
 - T25 Torx wrench
 - 32mm Headset wrench
 - 15mm Pedal wrench
 - 8, 9, 10, 11mm box wrenches
 - Tire levers (2)

- FINISHES**
- Galvanized**
An after fabrication hot dipped galvanized finish is our standard option.
 - Powder Coat**
Our powder coat finish assures a high level of adhesion and durability by following these steps:
 1. Sandblast
 2. Epoxy primer electrostatically applied
 3. Final thick TGIC polyester powder coat

- MOUNT OPTIONS**
- Surface only**
Fixit has 10" diameter x .25" foot with four anchors per foot. Tamper-resistant fasteners are included.

- PUMP OPTIONS**
- No Pump**
 - Air Kit Prime**
 - Attached to Fixit
 - Separate
 - Air Kit 4**

- CANE STOP**
- Add Cane Stop** (Galvanized only)

A cane-detectable attachment beneath the hanger arms is available for improved safety. (Additional cost)

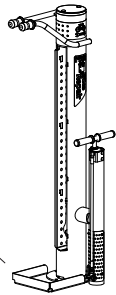

Setbacks

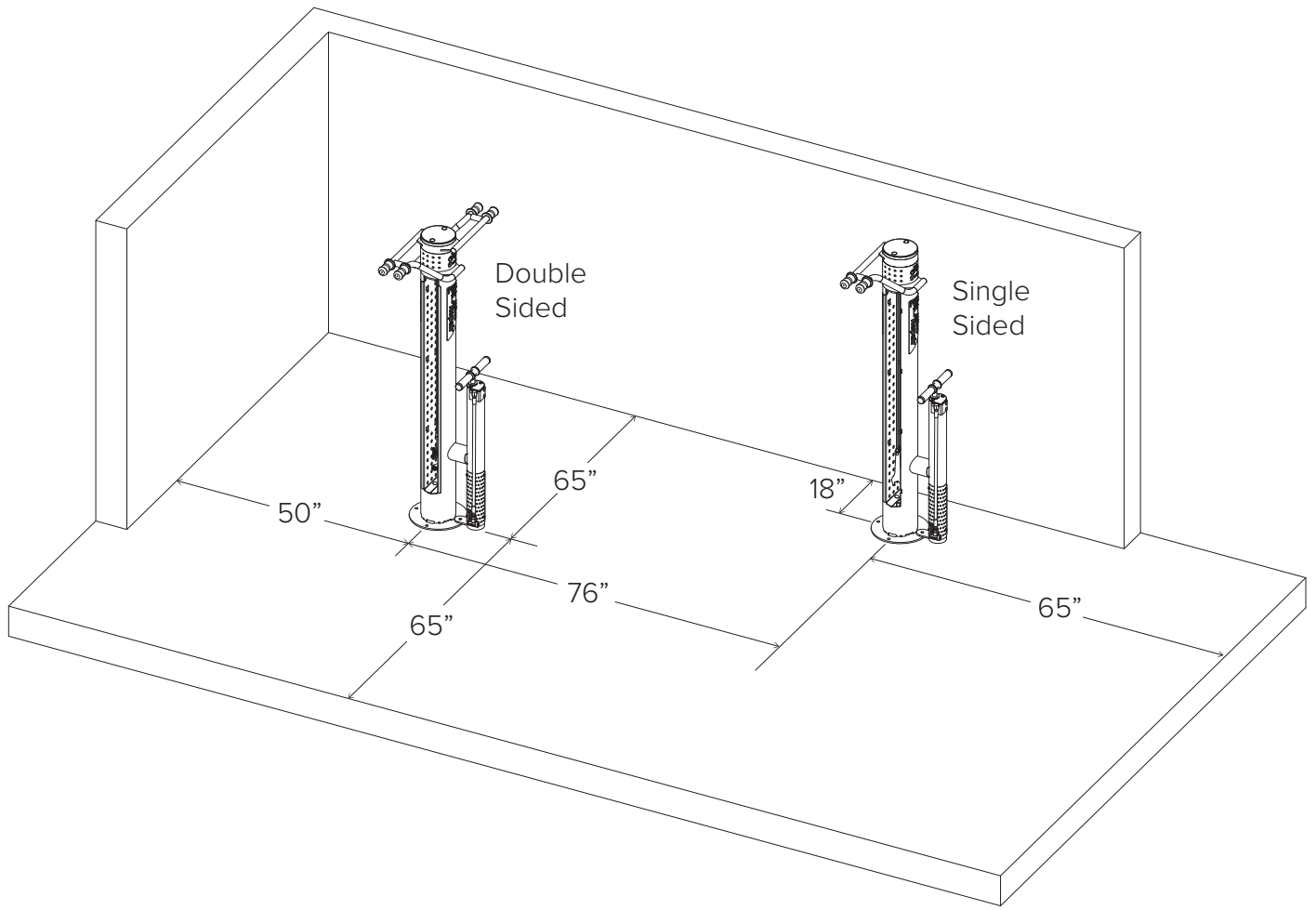



TOOLS NEEDED

Hammer drill
 3/8" masonry bit
 Hammer
 Socket Wrench
 9/16", 3/4" socket
 Tamper-proof socket (included)*
 Socket extension, 6" min.
 Razor blade

RECOMMENDED BASE MATERIAL

Solid concrete is the best base material for installation. To ensure the proper anchors are shipped with your rack, ask your representative which anchor is appropriate for your application. Be sure nothing is underneath the base material that could be damaged by drilling.



Be sure to save your tamper-resistant tools for any future maintenance. They are costly to replace.

If you are not attaching an Air Kit Prime to your Fixit, proceed to step 4

1

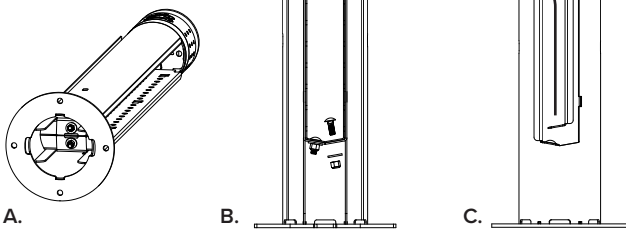

(A) Lay the Fixit Plus on its side.
 (B) Remove one 3/8" carriage bolt, lock nut, and washer.
 (C) The guard can then be pushed up and then pulled out.
 Set the guard aside.

2

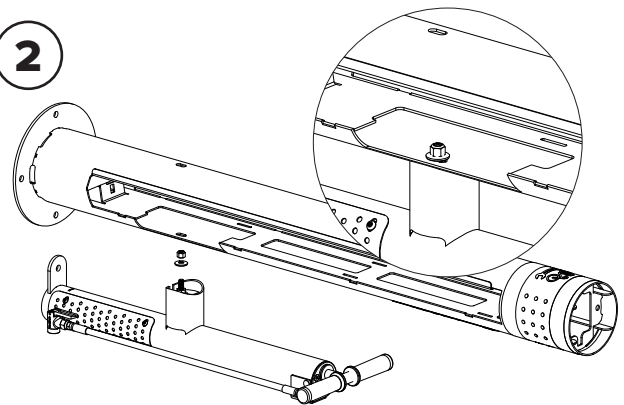

Secure the Air Kit to the side of the Fixit Plus with the 3/8" threaded stud on the Air Kit and a bonded washer and lock nut inside the Fixit Plus.

3

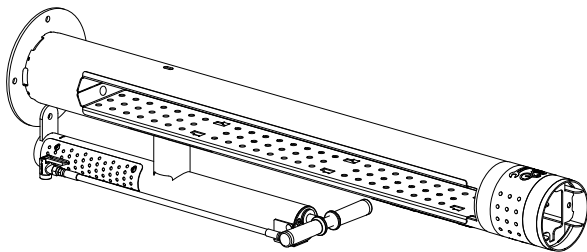

Re-attach the guard.

4

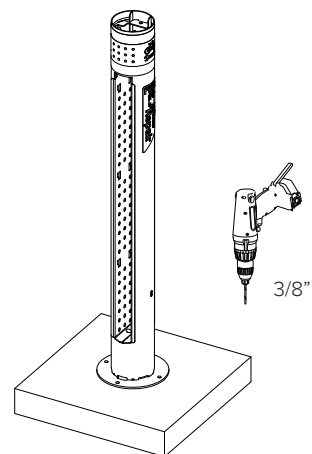

Reference the Fixit Plus setback recommendations and place the upright in the desired location. Use the base as a template to mark anchor locations and drill (4) 3/8" x 3" holes in the concrete with a hammer drill and masonry bit. Clean up all concrete dust from drilling.



If installing the optional cane stop, place the attachment under the base of the Fixit Plus.

5

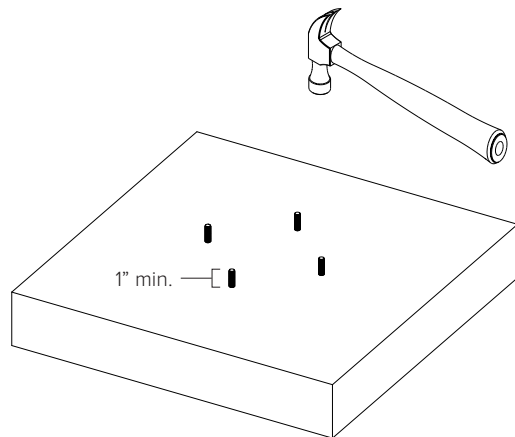

Hammer in the (4) 3/8" wedge anchors. Leave at least 1" inch of exposed threads above the concrete.

6

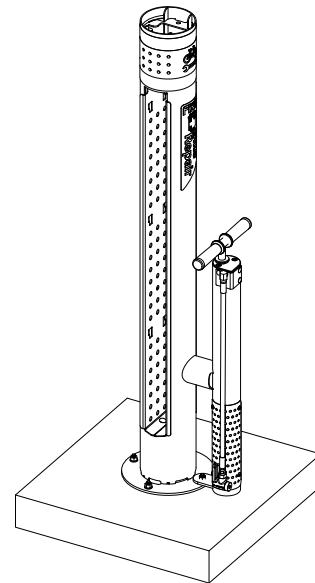

Place the Fixit Plus over the anchors, add washers and nuts, and tighten all nuts.

7

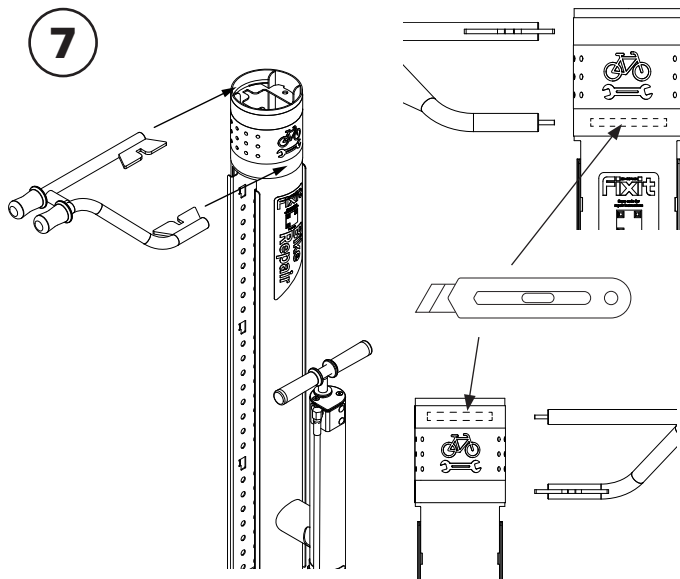

Select the orientation of the bike hanger and use a new razor blade to cut through the decal to reveal the corresponding slot in the Fixit Plus.

8

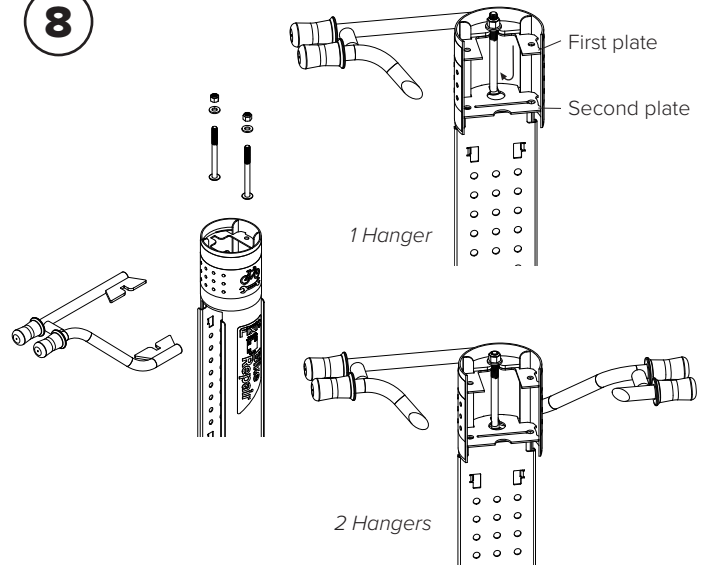

Add the 1/2" washer and 1/2" lock nut to the 1/2" x 6" carriage bolt. Insert the assembled hardware, headfirst, into the top of the Fixit Plus. The carriage bolt head will pass through the second plate hole and then slide sideways, so the carriage bolt engages the slot in both plates and bike hanger. Tighten the lock nut and repeat with the other side. If two bike hangers are used, the carriage bolt will also engage the second bike hanger under the second plate.

9

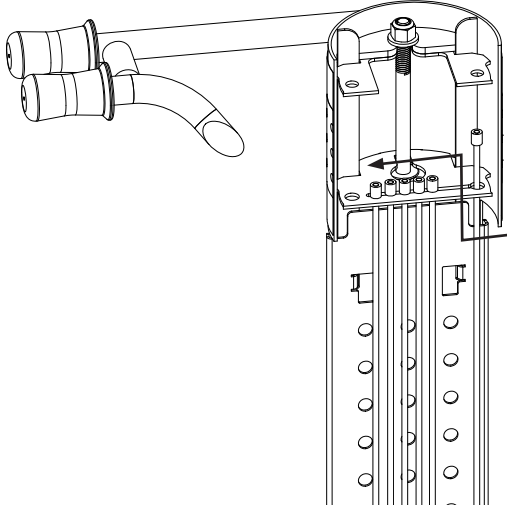

Insert the tool cables into the cable slot in the Fixit Plus upright.

10

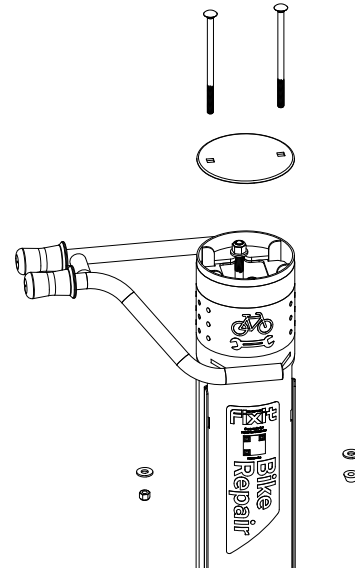

Place the top cap on the Fixit Plus and insert the (2) 3/8" x 7" carriage bolts through the top cap, first plate, and second plate of the Fixit Plus. Secure the carriage bolts with washers and nuts. The Penta nut goes over the hole the tool cables were inserted into.

Concrete foundation recommendations

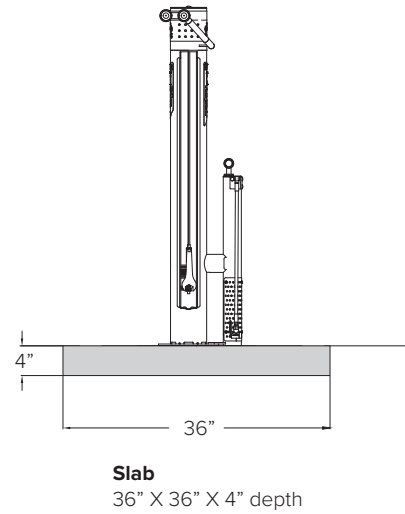
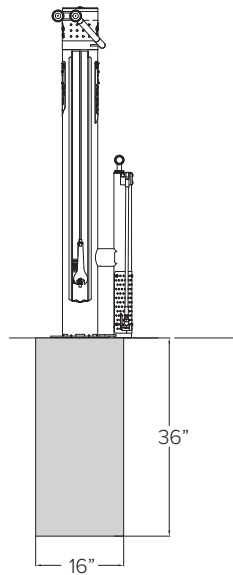

Installation Cane Stop

See diagrams below for guidance on installing the optional Cane Stop. This attachment provides a cane-detectable barrier beneath the hanger arms of the Fixit for improved safety.

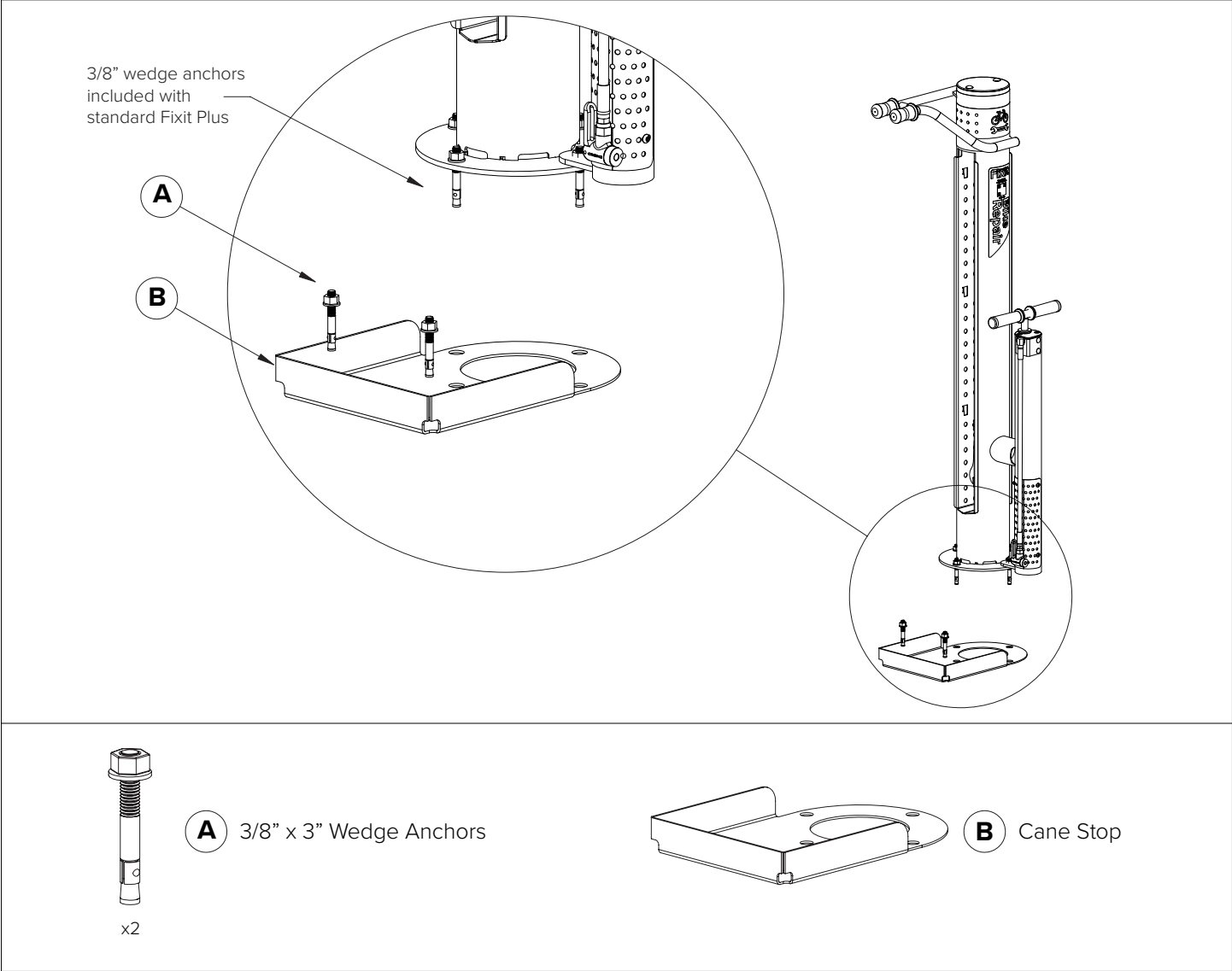

NOTE

All threads for all parts of the pump are right-hand threads. They tighten clockwise, and loosen counter-clockwise ("righty tighty, lefty loosey"). However, when you are looking top-down at a bolt that threads from underneath, if you move it counter-clockwise from your point of view, you are actually tightening, not loosening, the nut! This has led to some unnecessary breakage of pump parts. Be sure you are looking at the nut with the proper orientation before tightening or loosening.

REMOVING THE AIR KIT FROM THE FIXIT PLUS

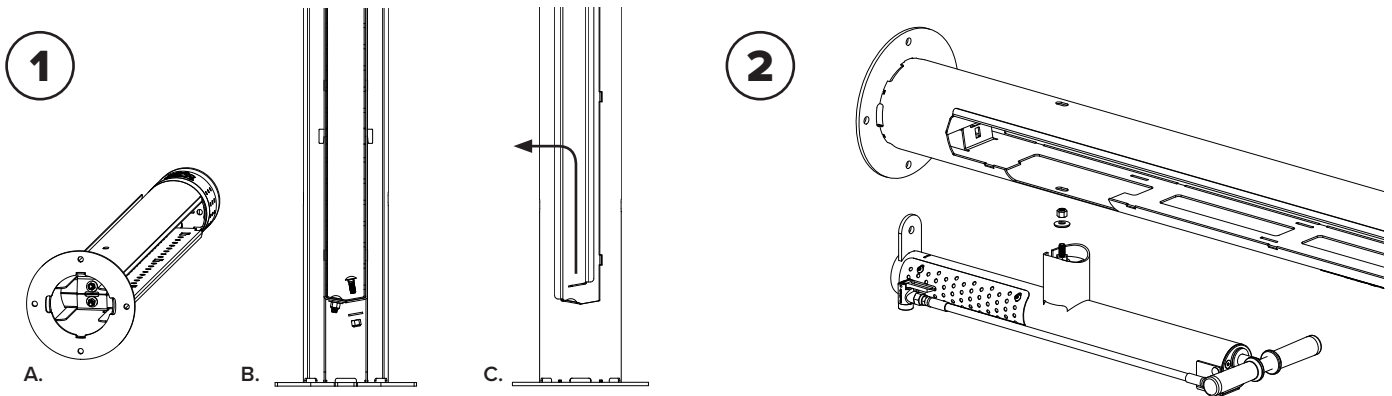

(A) Lay the Fixit Plus on its side.

(B) Remove one 3/8" carriage bolt, lock nut, and washer.

(C) The guard can then be pushed up and then pulled out. Set the guard aside.

Remove nut attaching the Air Kit to the side of the Fixit Plus.

REPLACING TOOLS

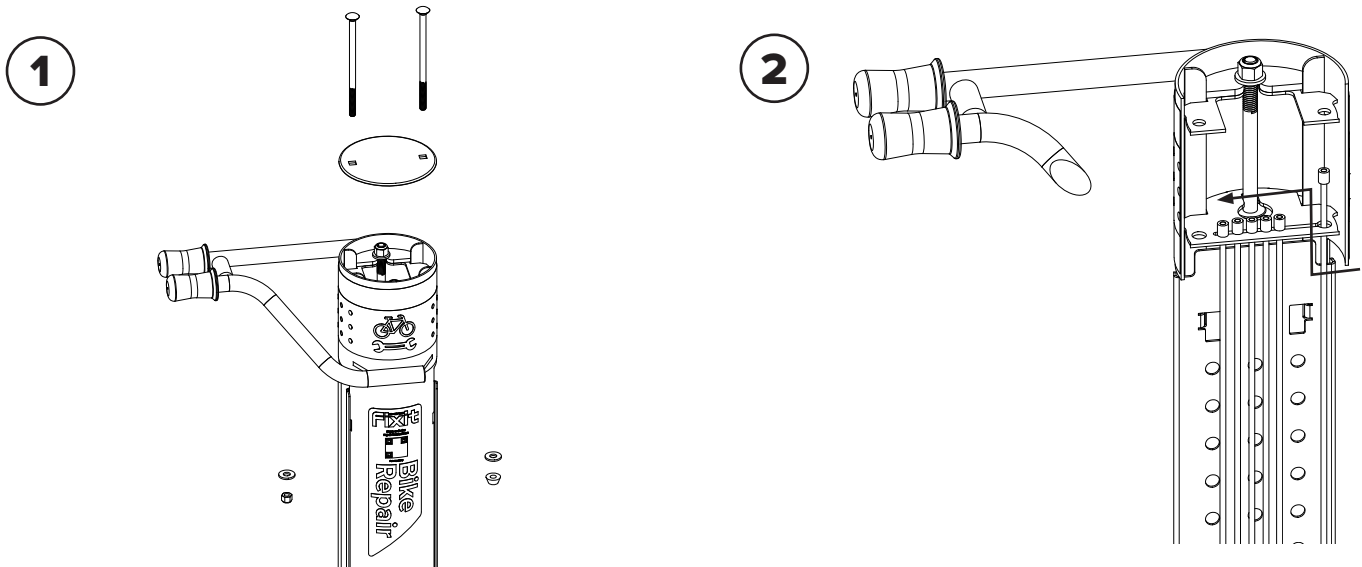

Remove the 3/8" nut and penta tamper-proof nut from the underside of the top compartment and lift out the carriage bolts. These are all best removed with a socket wrench, using the extension tool to enable you to reach the nuts.

Add or remove tools by sliding the tool cables through the hole at the end of the cable slot in the Fixit Plus upright.