

BILL OF MATERIALS				
NO.	PART NUMBER	DESCRIPTION	QTY	NOTES
1	167011	1/2"-13 ZINC FLANGE TOP LOCK NUT	3	
2	352013	WOOD ASSEMBLY	1	
3	TF1997	1/2" ELEVATOR BOLTS	4	

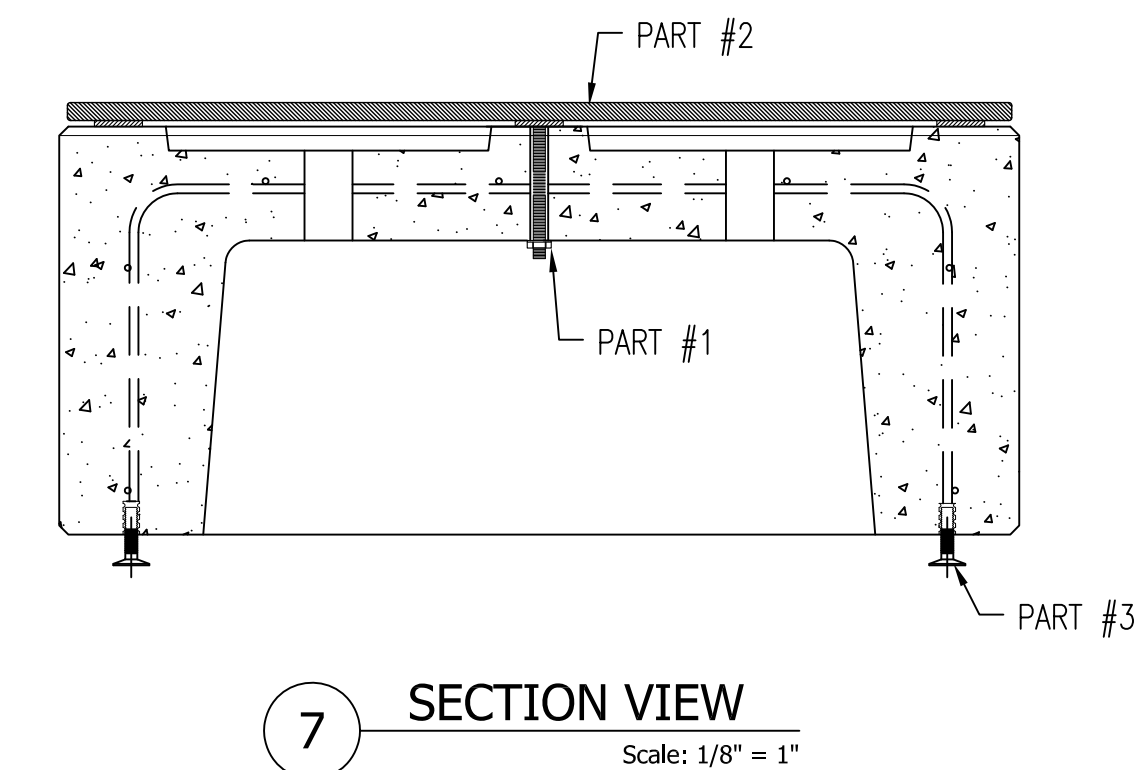
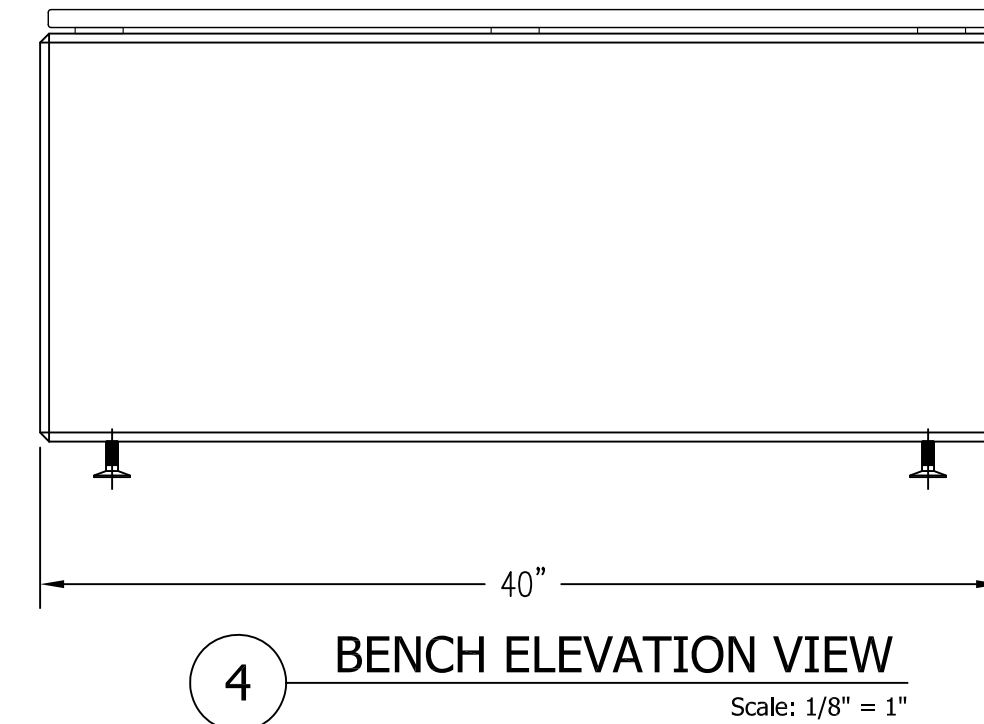
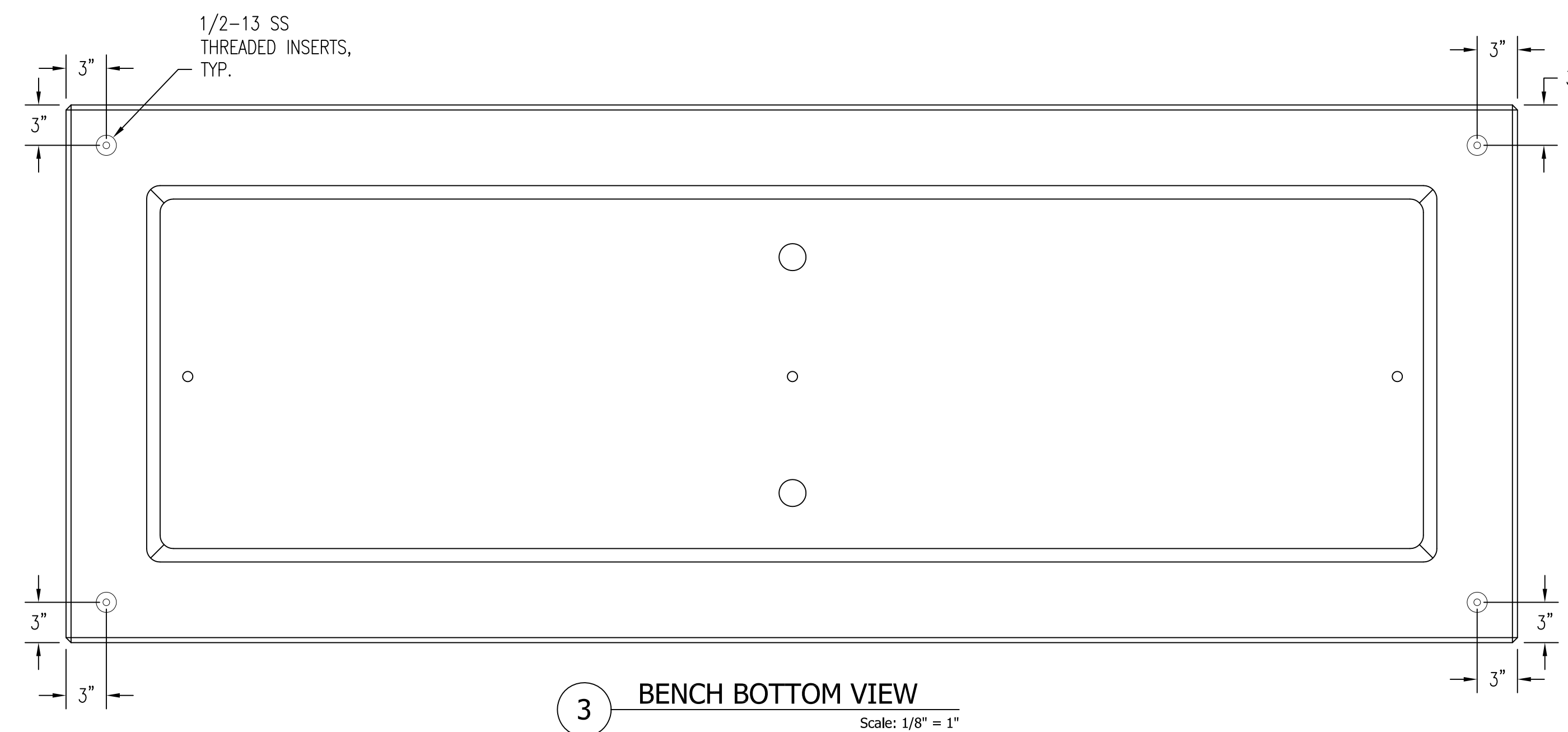
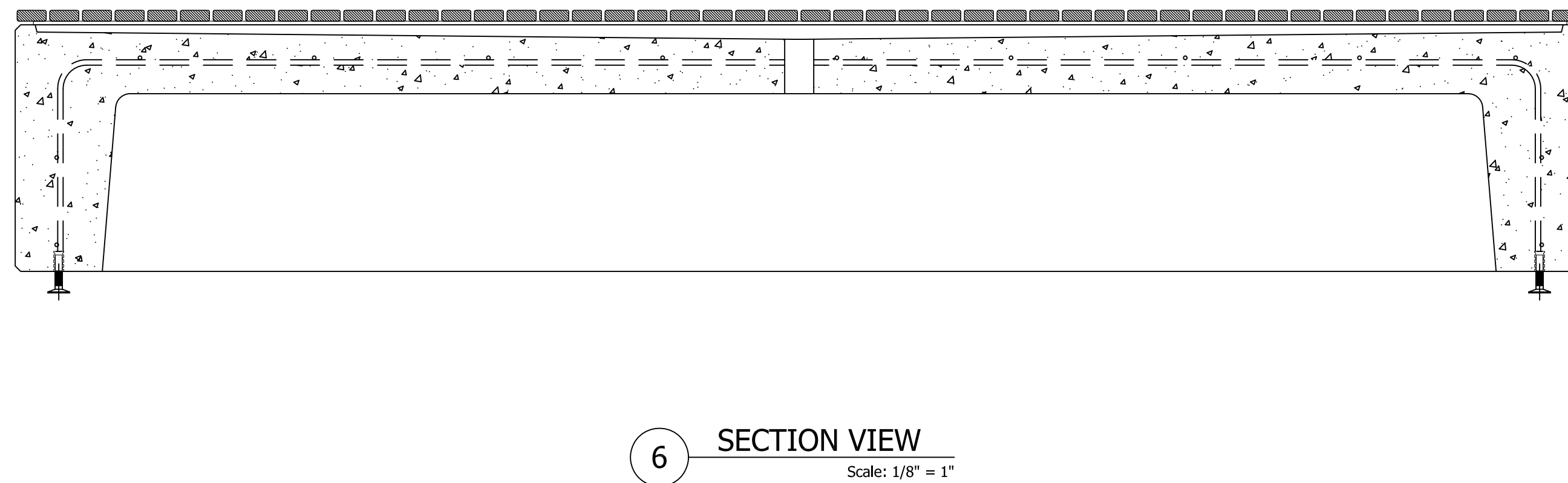
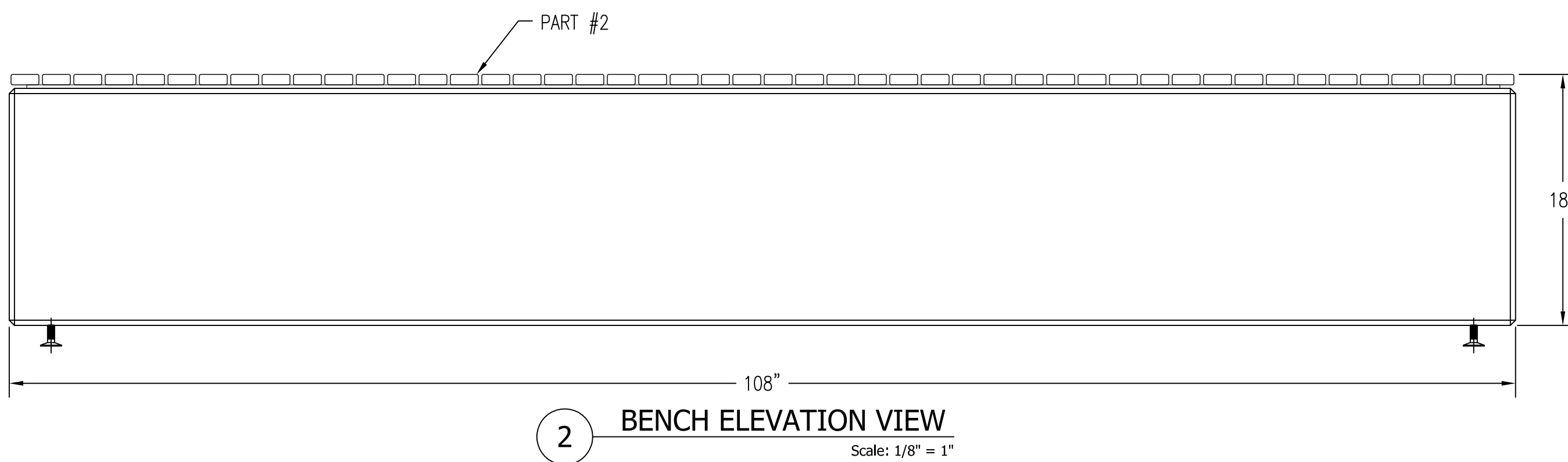
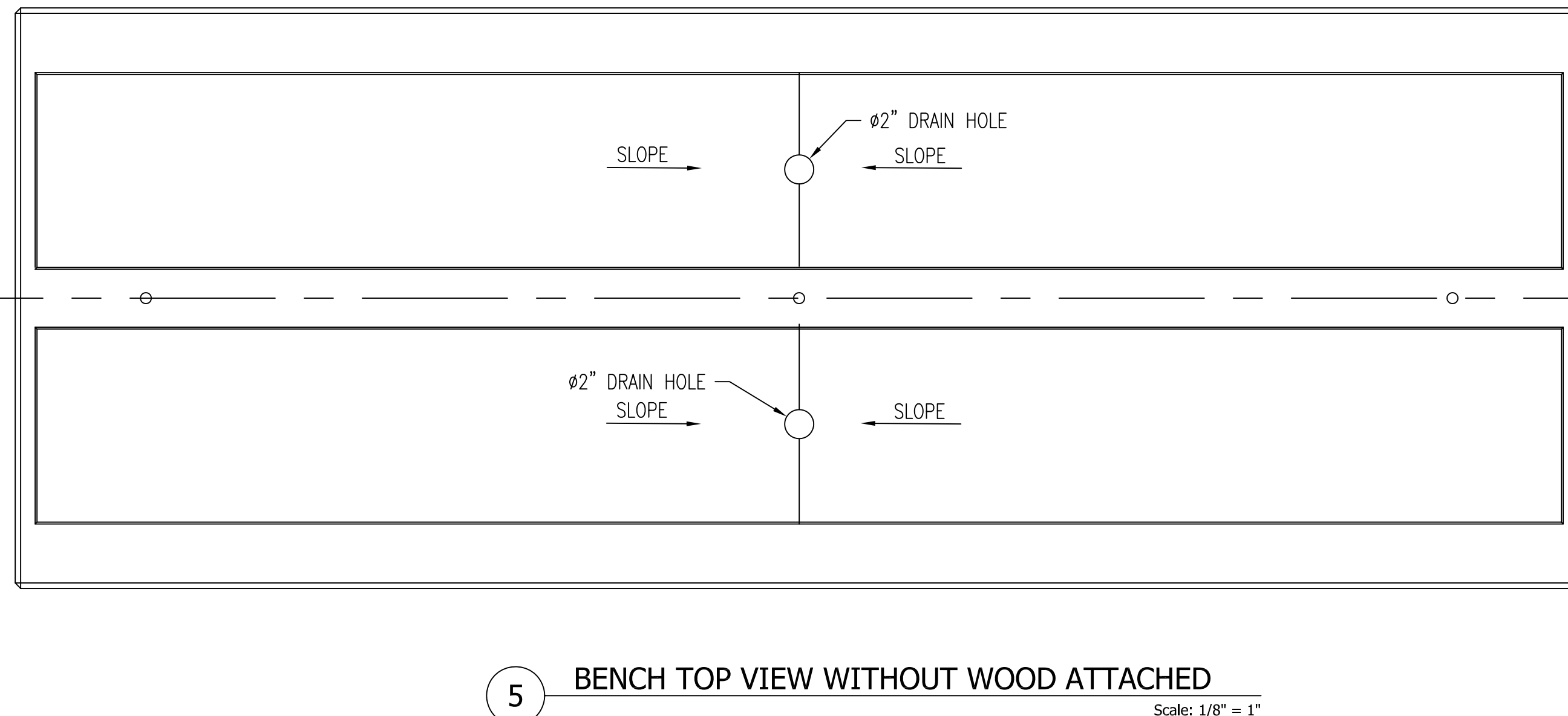
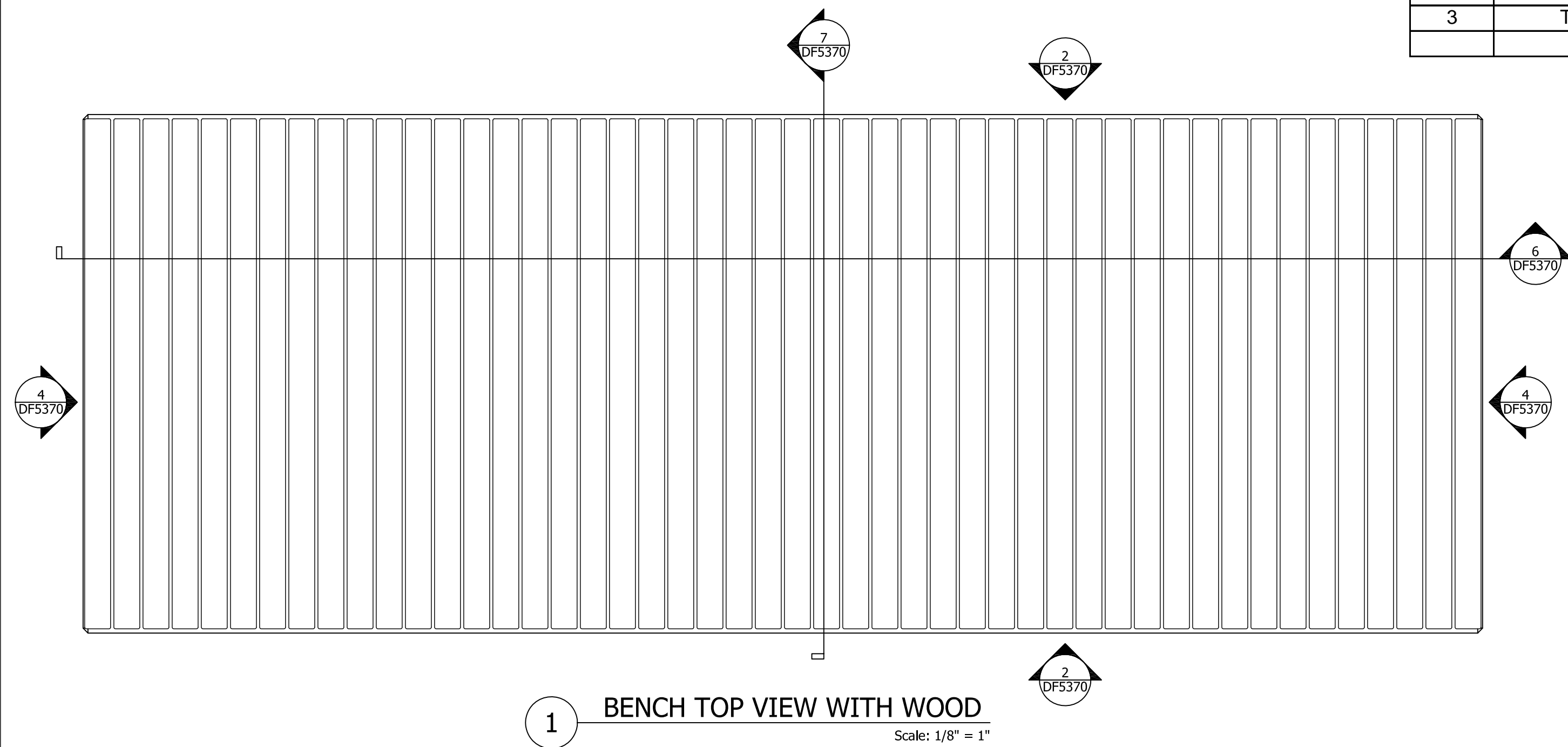

PROPRIETARY AND CONFIDENTIAL
THE INFORMATION CONTAINED IN THIS DRAWING IS THE SOLE PROPERTY OF Park Warehouse, LLC. 5301 North Federal Highway, Suite 140, Boca Raton, FL. ANY REPRODUCTION IN PART OR AS A WHOLE WITHOUT THE WRITTEN PERMISSION OF Park Warehouse, LLC. 5301 North Federal Highway, Suite 140, Boca Raton, FL. IS PROHIBITED.