

Vault Bar

SKU: 622ft155

ActionFit Traditional

PARTS LIST		
DESCRIPTION	QTY	PART NUMBER
VAULT BAR	1	403572
MOUNTING PLATE	1	309644
HARDWARE COMPLETE	1	403544
VAULT BAR SIGN	1	403563*
1/4" FLAT WASHER (5/8" O.D.)	2	817408*
1/4" x 3" P.B.H.C.S. w/Patch	2	812022*

Unless Otherwise Specified, All Units of Measure are Each

**Items listed below Hardware Complete line are included with Hardware Complete Number*

Warning: During Installation, Hardware And Small Parts Are Choking Hazards For Young Children. Store Unused Parts Appropriately Until Assembly Is Completed. Once Assembly Is Completed, Remove Any Unused Parts From The Play Environment And Dispose/Save Them In A Secure Location.

Note: Peen Tee-Nuts and Flatwashers to match radius of pipe after assembly is complete.

Note: Loctite (supplied by others) should be used on any non-patch hardware.

SPECIFICATIONS:

VAULT BAR: Bar is bent from 2-3/8" O.D. 10 gauge galvanized steel tubing with a brown polyester-powder coated finish.

SIGN: 1/2" thick solid color D.H.P.L.

SIGN POST: Shall be an all welded construction consisting of 2 3/8" o.d. Schedule 40 tubing and a 3/16" thk. 8" dia. hot rolled steel mounting plate. Assembly shall have a black powder coat finish.

HARDWARE: All nuts, bolts, screws, inserts, and lockwashers used in the assembly of all play equipment, shall be stainless steel, yellow dichromate plated steel, blue-coat plated steel, mechanically galvanized or powder coated/yellow dichromate plated steel. All primary fasteners shall be 300 series stainless steel. Fasteners with yellow dichromate treatment have an electro deposited, 99.9% pure zinc substrate applied from a specially formulated solution sealed with a yellow dichromate top coat designed to work in conjunction with the zinc plating. Yellow dichromate has a 320% longer life to white corrosion and 275% longer to red corrosion than does hot-dip galvanizing.

INSTALLATION INSTRUCTIONS:

1. Before starting assembly, review the General Installation Instructions at the beginning of this Installation Guide and the Typical Assembly Details in the back.
2. Determine proper location for Vault Bar Station. Refer to Equipment Layout Plan provided and any applicable project site drawings.
3. Dig footings for Vault Bar Station. Maintain footing spacing, size and depth as indicated on the Plan View. Allow for depth of desired Finished Surface.
4. Attach Sign & Mounting Plate to Vault Bar using 1/4 " x 3" P.B.H.C.S. w/ Patch and 1/4" Flat Washer (5/8"O.D.). See detail 060.
5. Position Vault Bar Station in footings; align, plumb, and brace vault bar in place & pour concrete. Be sure to hold top of concrete footing 0'-10" [25.40cm] down from the Finished Surface. Slope top of concrete for proper drainage.
6. Allow concrete a minimum of 48 hours to cure and harden before using Vault Bar Station.

MAINTENANCE PROCEDURE:

Periodically check hardware for tightness, and tighten as necessary. Always check parts for breakage or wear, and immediately put equipment out of service until any faulty parts are repaired or replaced. Check all decks for Plastisol coating peeling and touch up with Plastisol if necessary. Check for obstructed holes on deck, clean if necessary. Periodically check resilient surfacing for appropriate depth, and remove extraneous materials that could cause injury, infection, or disease. Maintain detailed installation, inspection, maintenance, and repair records for each public-use playground equipment.

Vault Bar

SKU: 622ft155

ActionFit Traditional

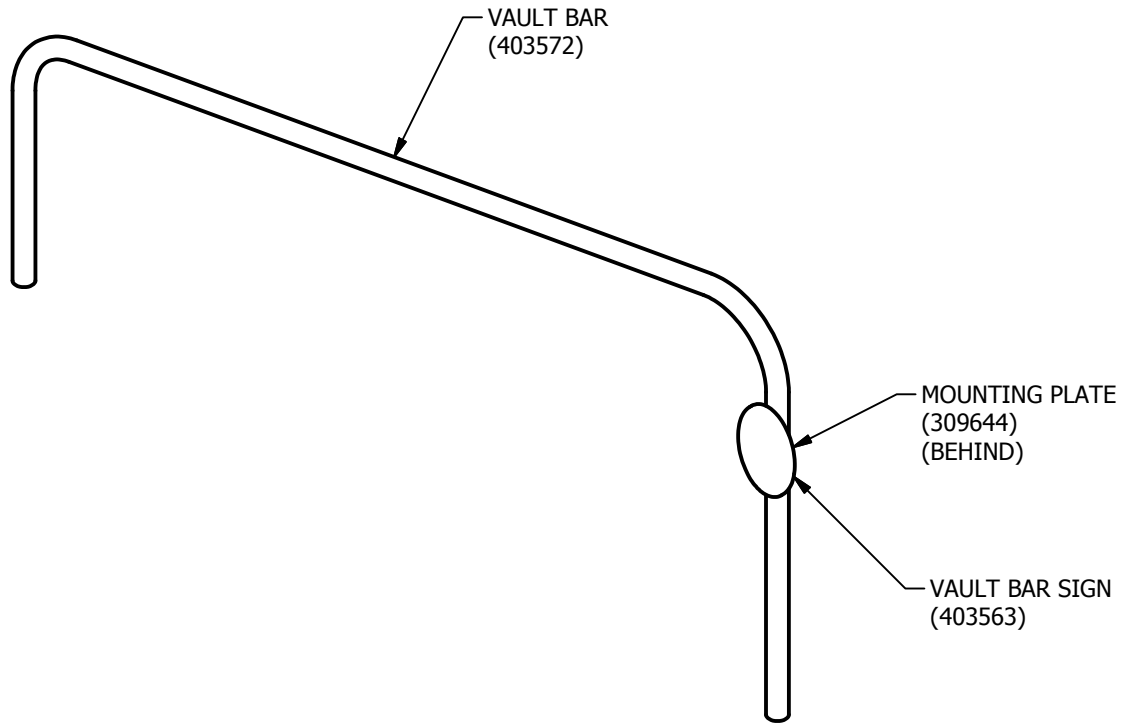

FINISHED ASSEMBLY

 = INSTALLATION DETAIL

Vault Bar

SKU: 622ft155

ActionFit Traditional

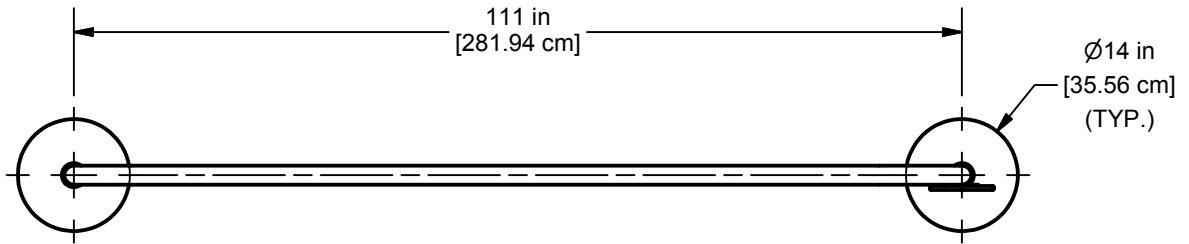

PLAN VIEW

CONCRETE REQUIRED:

.14 CUBIC YARDS
[.10 CUBIC METERS]

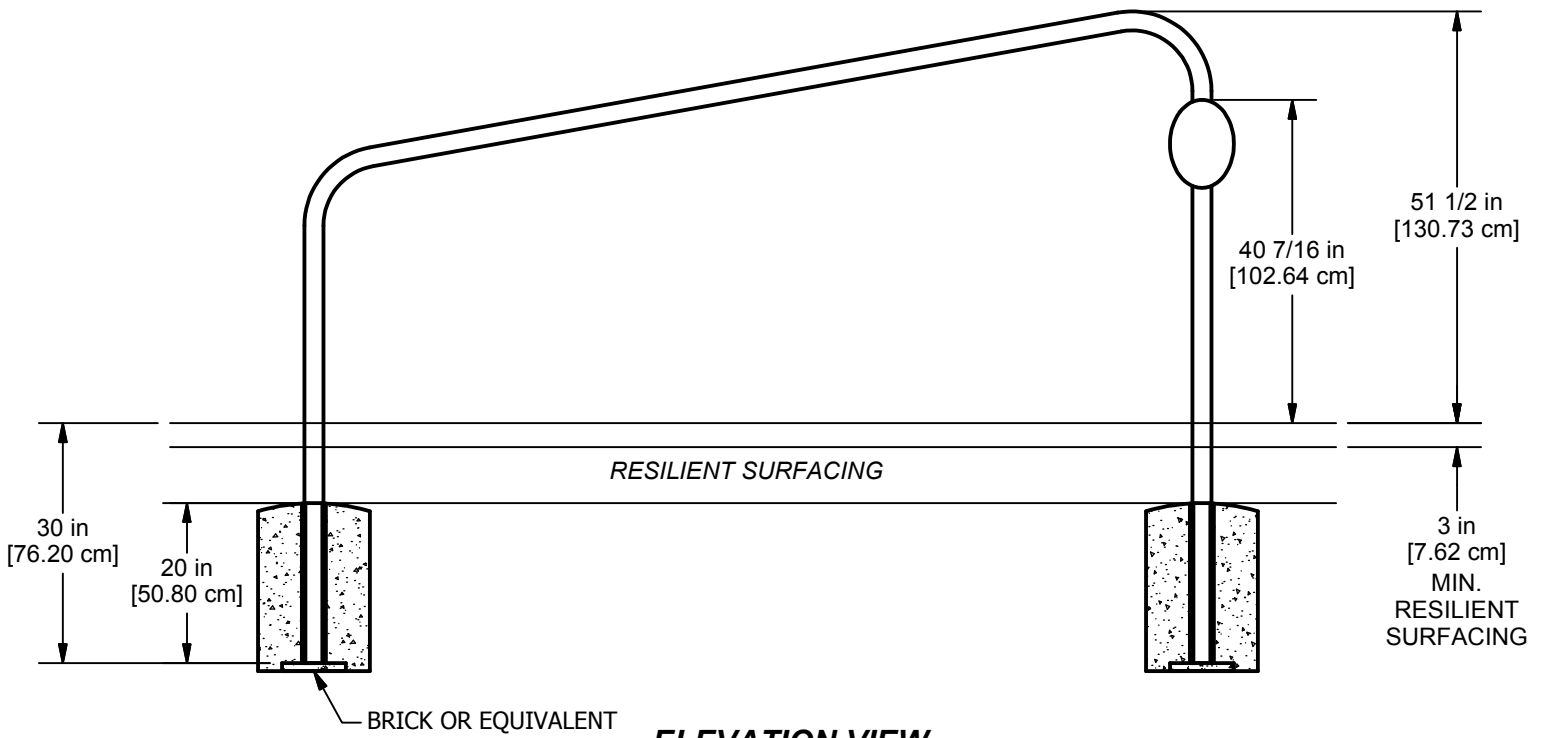

ELEVATION VIEW

