

Log Hop

SKU: 622ft120

ActionFit Traditional

PARTS LIST		
DESCRIPTION	QTY	PART NUMBER
LOG HOP	4	147845
SIGN POST	1	206182
HARDWARE COMPLETE	1	403536
LOG HOP SIGN	1	403555*
ANCHOR ROD (1'-0" [30.48cm])	4	135038*
1/4" FLAT WASHER (5/8" O.D.)	2	817408*
1/4" x 1/2" P.B.H.C.S. w/Patch	2	812011*

Unless Otherwise Specified, All Units of Measure are Each

**Items listed below Hardware Complete line are included with Hardware Complete Number*

Warning: During Installation, Hardware And Small Parts Are Choking Hazards For Young Children. Store Unused Parts Appropriately Until Assembly Is Completed. Once Assembly Is Completed, Remove Any Unused Parts From The Play Environment And Dispose/Save Them In A Secure Location.

Note: Peen Tee-Nuts and Flatwashers to match radius of pipe after assembly is complete.

Note: Loctite (supplied by others) should be used on any non-patch hardware.

SPECIFICATIONS:

LOG HOP: Shall be an all-welded construction fabricated of 3-1/2" O.D. (13 gauge) galvanized pipe and 2-7/8" O.D. standard galvanized pipe. Assembly shall also consist of a cast aluminum cap and self-sealing pop rivets.

SIGN: 1/2" thick solid color D.H.P.L.

SIGN POST: Shall be an all welded construction consisting of 2 3/8" o.d. Schedule 40 tubing and a 3/16" thick hot rolled steel mounting plate. Assembly shall have a black powder coat finish.

FINISH: The Log Hop Assembly shall have a powder coat finish.

HARDWARE: All nuts, bolts, screws, inserts, and lockwashers used in the assembly of all play equipment, shall be stainless steel, yellow dichromate plated steel, blue-coat plated steel, mechanically galvanized or powder coated/yellow dichromate plated steel. All primary fasteners shall be 300 series stainless steel. Fasteners with yellow dichromate treatment have an electro deposited, 99.9% pure zinc substrate applied from a specially formulated solution sealed with a yellow dichromate top coat designed to work in conjunction with the zinc plating. Yellow dichromate has a 320% longer life to white corrosion and 275% longer to red corrosion than does hot-dip galvanizing.

INSTALLATION INSTRUCTIONS:

1. Before starting assembly, review the General Installation Instructions at the beginning of this Installation Guide and the Typical Assembly Details in the back.
2. Determine proper location for Log Hop rails. Refer to Equipment Layout Plan provided and any applicable project site drawings.
3. Dig footings for the Log Hop. Maintain footing spacing, size and depth as indicated on the Plan View. Allow for depth of desired Finished Surface.
4. Attach Sign to Sign Post using 1/4 " x 1/2" P.B.H.C.S. w/ Patch and 1/4" Flat Washer (5/8"O.D.). See Detail 059.
5. Position Log hop in footings; align, plumb, and brace posts in place. Pour concrete as shown on elevation view. Be sure to hold top of concrete footing 10" [25.40cm] down from the Finished Surface. Slope top of concrete for proper drainage.
6. Allow concrete a minimum of 48 hours to cure and harden before using Log Hop station.

MAINTENANCE PROCEDURE:

Periodically check hardware for tightness, and tighten as necessary. Always check parts for breakage or wear, and immediately put equipment out of service until any faulty parts are repaired or replaced. Check all decks for Plastisol coating peeling and touch up with Plastisol if necessary. Check for obstructed holes on deck, clean if necessary. Periodically check resilient surfacing for appropriate depth, and remove extraneous materials that could cause injury, infection, or disease. Maintain detailed installation, inspection, maintenance, and repair records for each public-use playground equipment.

Log Hop

SKU: 622ft120

ActionFit Traditional

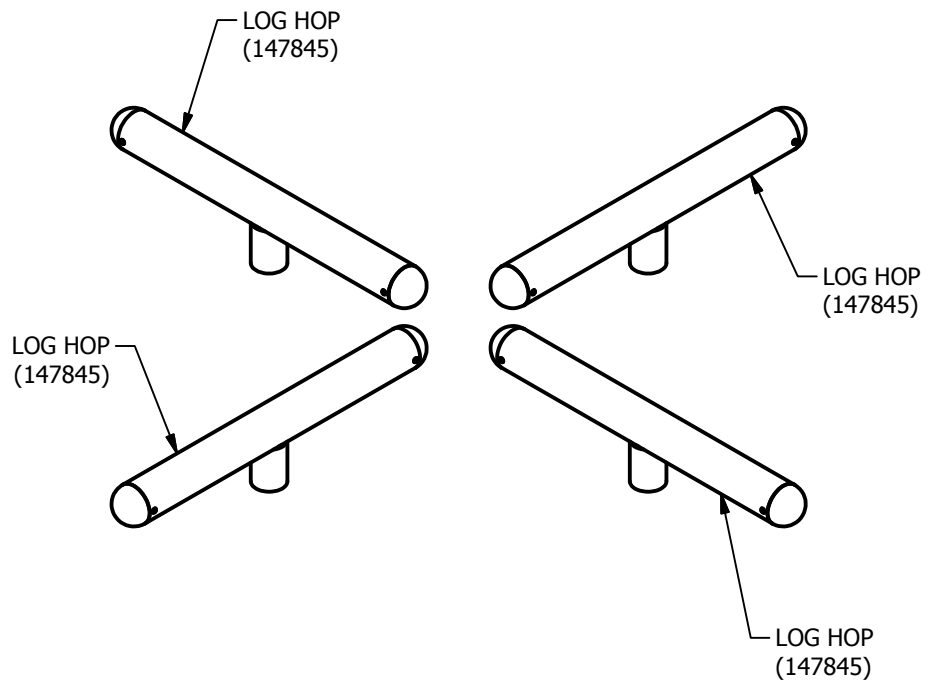
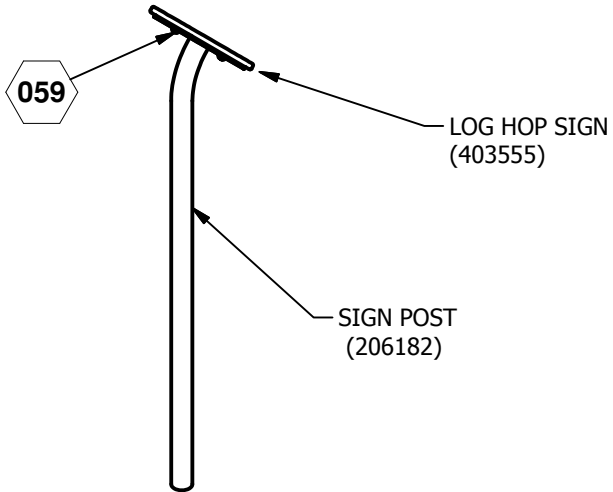

FINISHED ASSEMBLY

 = INSTALLATION DETAIL

Log Hop

SKU: 622ft120

ActionFit Traditional

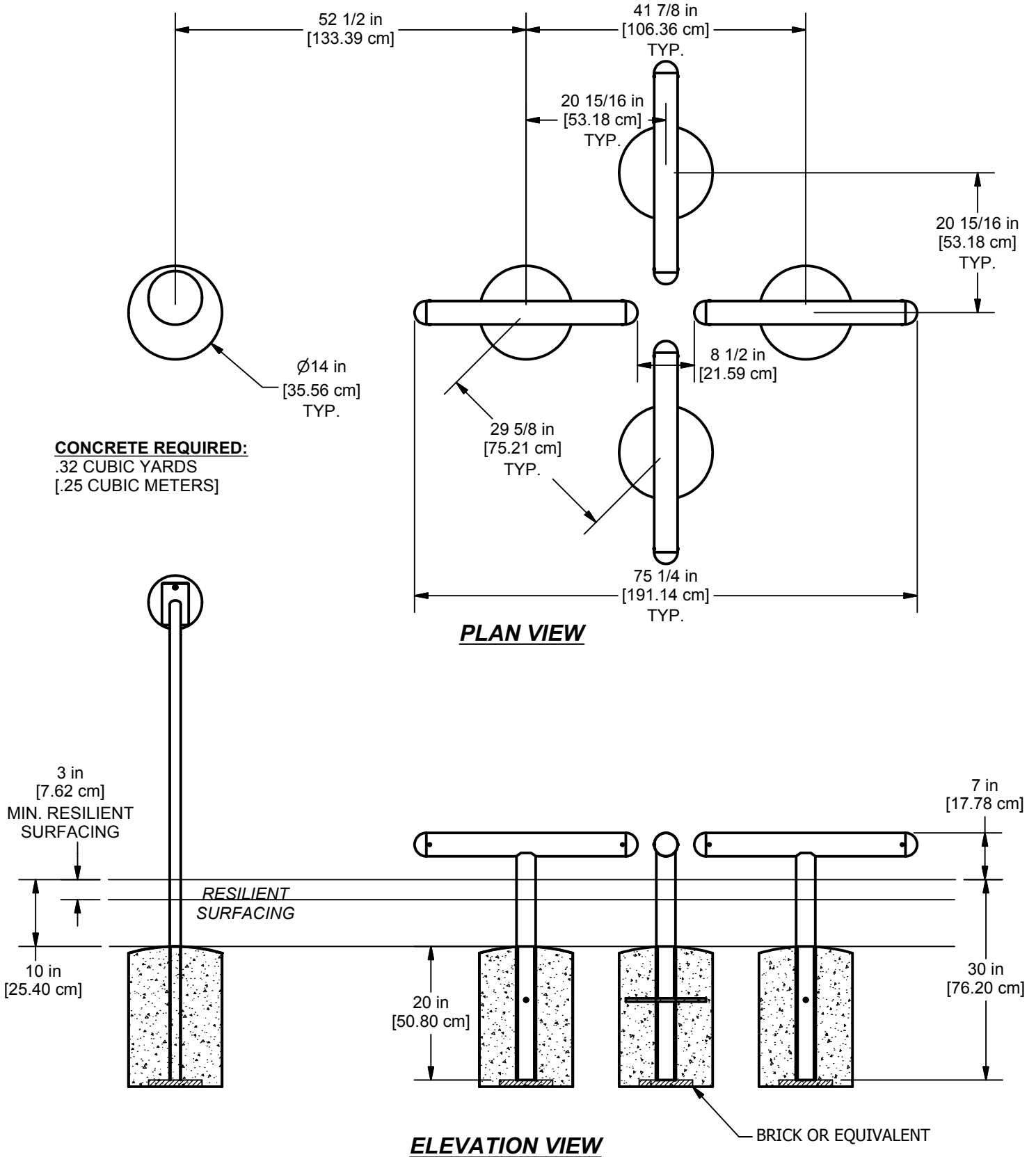

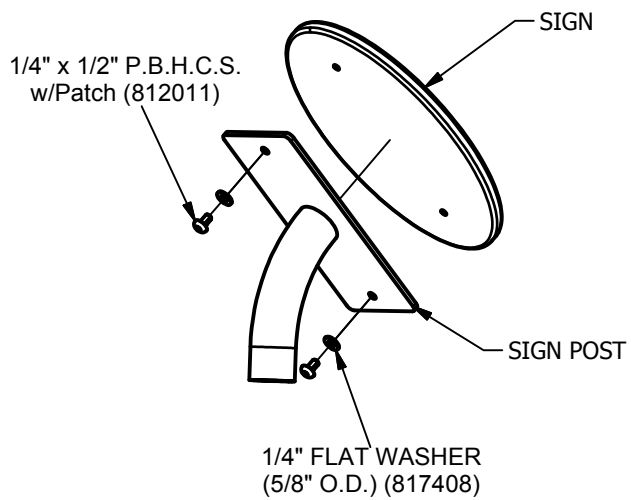
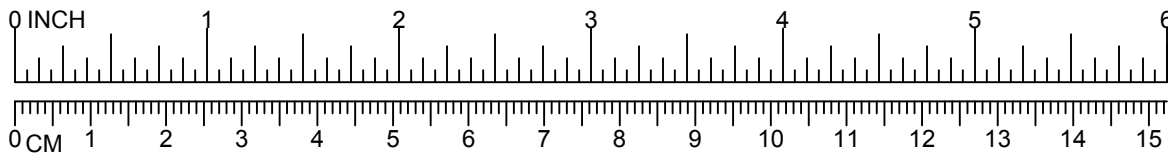

059