

# PLAN

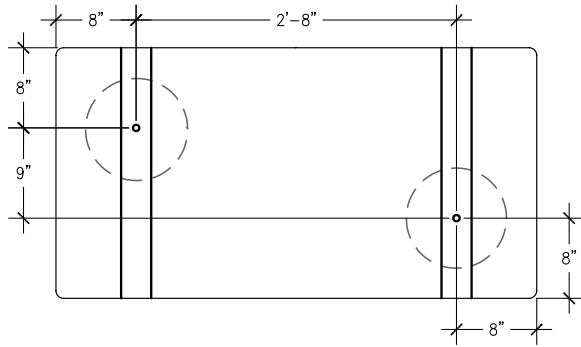

# ELEVATION

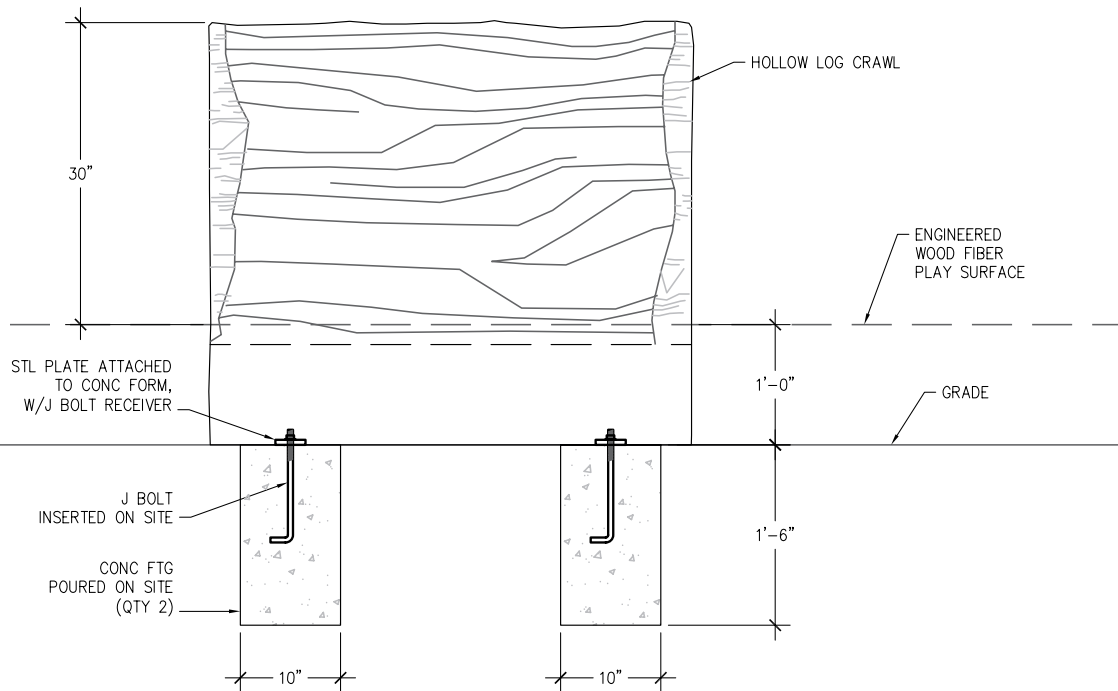

## Nature Bark 4' Log Tunnel

SKU: 622dp270-1



# INSTALLATION INSTRUCTIONS

## **Tools Required:**

- Skidster *or* Fork Lift Truck
- Shovel /Auger
- Nylon lifting strap, minimum 8' length  
Note: Rated for 2,500 lbs. minimum
- Concrete  
Note: Rated for 2,500 psi minimum

**Weight:** 1250 lbs. per Log Tunnel

**Step 1:** Thoroughly inspect all pieces before unloading for damages incurred during shipping.

**Step 2:** Establish layout of Log Tunnel and dig footing holes.

**Step 3:** Either put blades of fork truck through center, or wrap nylon strap through center of Log Tunnel for lifting. Use foam packing material to cushion and prevent damage. Carefully place Log Tunnel over footing holes.

**Step 4:** Thread J-bolts into inserts (Qty = 2) at the base of the Log Tunnel. Make sure J-bolts are centered in footing holes.

**Step 5:** Fill footing holes with concrete.

**Step 6:** Other concrete has hardened, remove all remaining packaging materials and inspect piece for blemishes. Use included touch-up kit as needed.

## GENERAL NOTES

- Due to variables in local soil conditions, footing sizes may vary to meet local codes.
- Actual on-site conditions may vary and may require modifications to installation method.
- Use care and caution while handling play pieces. Make sure all points of contact are protected from lifting straps or other machinery that may damage the piece.
- Bracing materials may be required during installation.

